

CSXI-0180-5-PP-N3R-CB-PD ON DWG

COMPONENT LIST

- CB1 - CIRCUIT BREAKER, 250A, 600V, 3PH, 18KAIC
- CR1 - CONTROL RELAY, 5A, 120V, 4-POLE
- CR2 - CONTROL RELAY, 5A, 120V, 4-POLE
- CSXI - SOFT STARTER, CSXI SERIES, 200A, 380-600V, BYPASSED
- ENCL - ENCLOSURE, WALL MOUNT, TYPE 12/4, 24"H x 20"W x 10"D
- FU1-2 - CONTROL FUSES (PRIMARY SIDE), TIME DELAY, 0.3A, 600V, 200KA CLASS CC
- FU3 - CONTROL FUSES (SECONDARY SIDE), TIME DELAY, 0.8A, 500V, 10KA
- HTR - HEATER, 120V, 50W, RADIATED
- TB1 - CONTROL TERMINAL BLOCKS
- TSTAT - THERMOSTAT, 0-60 DEG C, NCC STYLE
- XF1 - CONTROL TRANSFORMER, 75VA, 575V PRIMARY - 120V SECONDARY
- LT1 - PILOT LIGHT, 22MM, PTT, ILLUMINATED, 120V, RED LED
- LT2 - PILOT LIGHT, 22MM, PTT, ILLUMINATED, 120V, GREEN LED
- LT3 - PILOT LIGHT, 22MM, PTT, ILLUMINATED, 120V, AMBER LED
- PB1 - PUSHBUTTON, 22MM, FLUSH GREEN, W/ N.O. CONTACT
- PB2 - PUSHBUTTON, 22MM, RAISED RED, W/ N.C. CONTACT
- SW1 - SELECTOR SWITCH, 22MM, 3-POSITION, W/ (2)N.O. CONTACTS

A
B
C
D
E
F
G
H
I
J
K
L
M
N

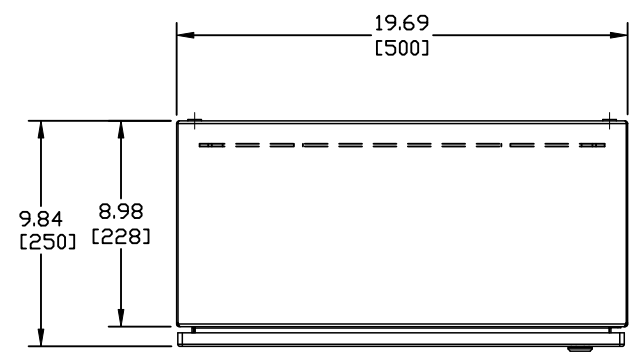

TOP VIEW

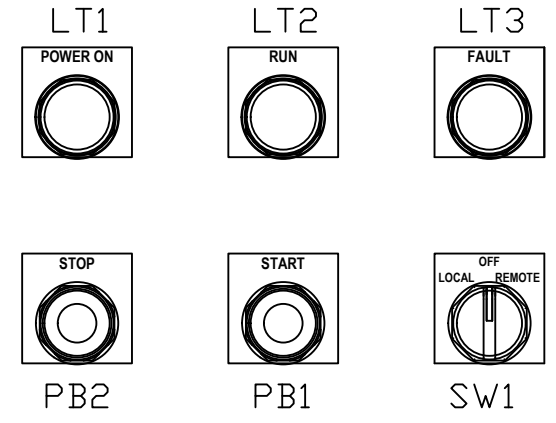

DOOR DEVICES (SCALE: 3x)

NOTES:

⚠ MOTOR CONTROLLER IS SUITABLE FOR USE AS SERVICE EQUIPMENT. IF MOTOR CONTROLLER IS GOING TO BE USED AS SERVICE EQUIPMENT, INSTALL "SERVICE DISCONNECT" LEGEND AS SHOWN. "SERVICE DISCONNECT" IS SHIPPED LOOSE WITH MOTOR CONTROLLER.

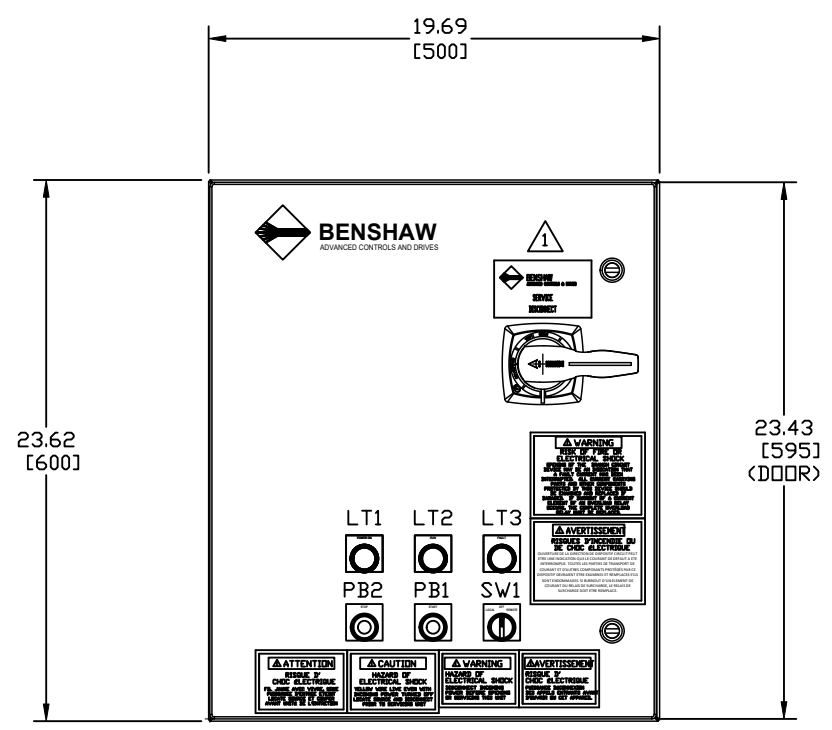

FRONT VIEW

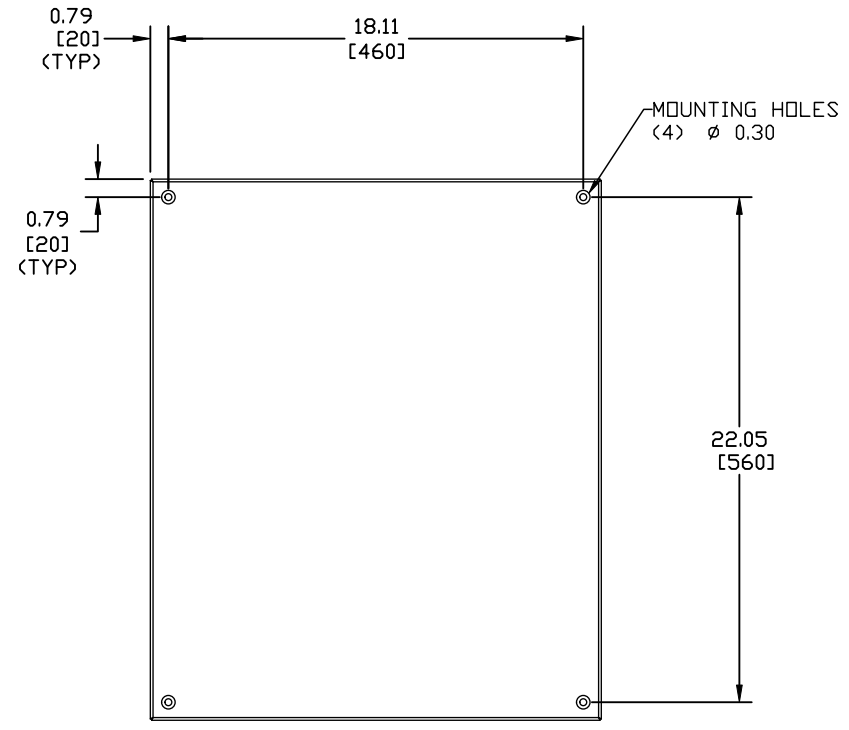

REAR VIEW (MOUNTING HOLES)

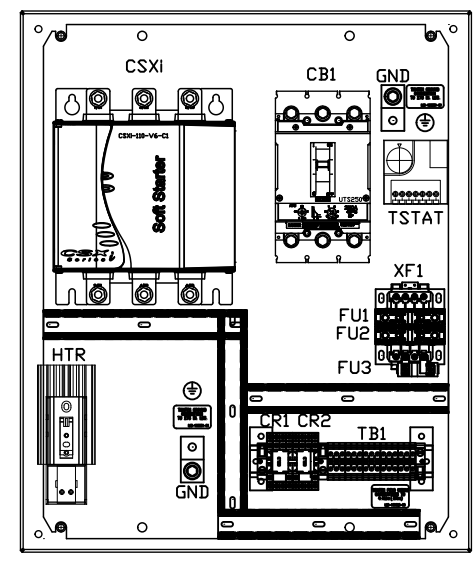

PANEL VIEW

APPROV: CHG BY: CHANGE:	REVISIONS DO NOT SCALE DWG	THIRD ANGLE PROJECTION ALL DIMENSIONS IN INCHES INTERPRET DRAWING PER ASME Y14.5M-1994 TOLERANCES: .XX ± .03 .XXX ± .015 ANGLES ± 1° MATERIAL: FINISH:	TITLE: ENCLOSURE LAYOUT CSXI-0180-5-PP-N3R-CB-PD 200HP (192 AMPS) @ 575V (400% CURRENT FOR 6 SECONDS STANDARD DUTY RATED)	SIGNATURES DATE DRWN: SKW 02/24/20 CHKD: MSN 02/28/20 ENG: MSN 03/31/20 MFG: SIZE: D DWG NO.: CSXI-0180-5-PP-N3R-CB-PD SCALE: 1:4	 BENSHAW 815 ALPHA DRIVE PITTSBURGH, PA 15238 550 BRIGHT STREET LISTOWEL, ONTARIO M4W 3W3	REV 0 SHEET 1 OF 2
-------------------------------	-------------------------------	---	--	--	--	--------------------------

CSXI-0180-5-PP-N3R-CB-PD

A
B
C
D
E
F
G
H
I
J
K
L
M
N

NOTES

- 1 WIRE SIZE RANGE: (1) 1/0-300kcmil
TIGHTENING TORQUE: 283.2LB-IN (32Nm) FOR 1/0-4/0AWG
TIGHTENING TORQUE: 389.4LB-IN (44Nm) FOR 250-300KCMIL
- 2 WIRE SIZE RANGE: BOLTED CONNECTION BUS TAB 1.34W x 0.12T, 0.33DIA
TIGHTENING TORQUE: GRADE 5 BOLT 1/4 OR (M6) 120LB-IN (22.6NM)
- 3 WIRE SIZE RANGE: (1) 6-250KCMIL
TIGHTENING TORQUE: 275LB-IN (31NM)
- 4 CUSTOMER SHOULD MONITOR FAULT CONTACTS OF RELAY (CR2) FOR FAULT DETECTION, AND REMOVE 2 WIRE RUN COMMAND WHEN A FAULT IS DETECTED.
- 5 CONTACT RATINGS:
240VAC 5A RESISTIVE 1.2A INDUCTIVE
30VDC 5A RESISTIVE 2A INDUCTIVE
- 6 CONTACT RATINGS:
250VAC 6A RESISTIVE
30VDC 6A RESISTIVE
- 7 REMOVE JUMPER WHEN INTERLOCKS ARE INSTALLED.
- 8 SELECT EITHER TWO OR THREE WIRE CONTROL.
- 9 STARTER SHIPPED SETUP FOR CUSTOMER SUPPLIED REMOTE 2 WIRE CONTROL.
- 10 IF CUSTOMER SUPPLIED REMOTE 3 WIRE CONTROL IS NEEDED MAKE CUSTOMER CONNECTIONS AS SHOWN.
- 11 REFER TO USER GUIDE FOR STARTER ADJUSTMENTS AND RESET IF TRIP OCCURS

STANDARD LEGEND

- WIRE NODE SYMBOL MAY HAVE TERMINAL BLOCK
- BENSHAW SUPPLIED TERMINAL BLOCK
- TERMINAL STRIP
- POWER CONNECTION
- PC BOARD TERMINALS
- TWISTED PAIR
- TWISTED SHIELDED PAIR
- SHIELDED WIRE
- FIELD WIRING

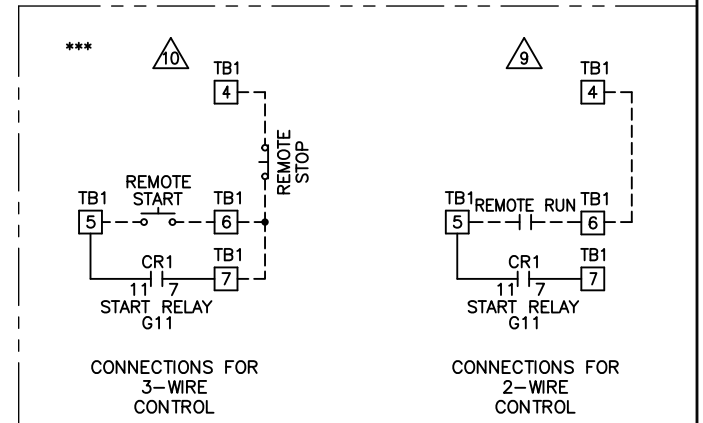
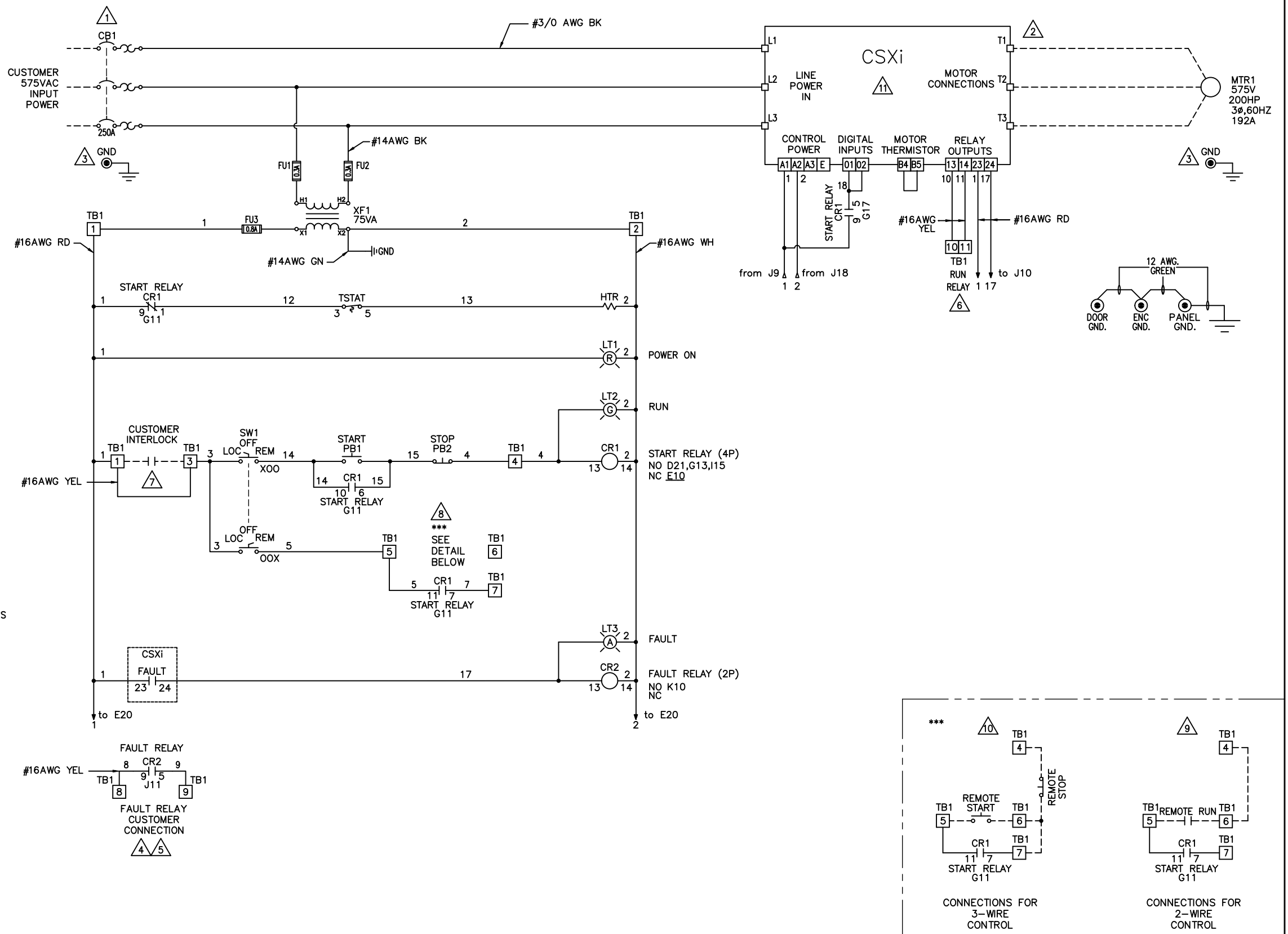

<p>APPRD: _____</p> <p>CHG BY: _____</p> <p>CHANGE: _____</p>	<p>REVISIONS</p> <p>DO NOT SCALE DWG</p>	<p>THIRD ANGLE PROJECTION</p> <p>ALL DIMENSIONS IN INCHES INTERPRET DRAWING PER ASME Y14.5M-1994</p> <p>TOLERANCES: .XX ± .03 .XXX ± .015 ANGLES ± 1°</p> <p>MATERIAL: _____</p> <p>FINISH: _____</p>	<p>UNLESS OTHERWISE SPECIFIED</p> <p>ALL DIMENSIONS IN INCHES INTERPRET DRAWING PER ASME Y14.5M-1994</p> <p>TOLERANCES: .XX ± .03 .XXX ± .015 ANGLES ± 1°</p> <p>MATERIAL: _____</p> <p>FINISH: _____</p>	<p>TITLE:</p> <p>SCHEMATIC</p> <p>CSXI-0180-5-PP-N3R-CB-PD</p> <p>200HP (192 AMPS) @ 575V</p> <p>(400% CURRENT FOR 6 SECONDS STANDARD DUTY RATED)</p>	<p>SIGNATURES DATE</p> <p>DRWN: SKW 02/24/20</p> <p>CHKD: MSN 02/28/20</p> <p>ENG: MSN 03/31/20</p> <p>MFR: _____</p>	<p>500 BRIGHT STREET</p> <p>LISTOWEL, ONTARIO</p> <p>M4W 3W3</p>	<p>615 ALPHA DRIVE</p> <p>PITTSBURGH, PA 15238</p>
<p>SCALE: 1:4</p>				<p>SIZE: D</p>	<p>CSXI-0180-5-PP-N3R-CB-PD</p>	<p>REV: 0</p>	<p>SHEET 2 OF 2</p>