

A
B
C
D
E
F
G
H
I
J
K
L
M
N

- NOTES:**
- 1 MINIMUM WIRE BENDING SPACE SHALL BE 12.00" FROM TOP OF CIRCUIT BREAKER POWER CONNECTION TO TOP OF ENCLOSURE.
 - 2 ENSURE THAT ALL RIBBON CABLES ARE ROUTED AWAY FROM POWER CONDUCTORS.
 - 3 MINIMUM WIRE BENDING SPACE SHALL BE 12.00" FROM BOTTOM OF POWERSTACK POWER CONNECTION TO BOTTOM OF ENCLOSURE.
 - 4 ENCLOSURE LAYOUT IS DESIGNED FOR CABLE ENTRY/EXIT TO BE TOP/BOTTOM.

- LEGEND**
- CB1 CIRCUIT BREAKER
 - CR1 4 POLE RELAY
 - CT4-6 OVERLOAD CT'S
 - DIS DOOR MOUNTED KEYPAD
 - FU4-5 PRIMARY FUSES (T1)
 - FU6 SECONDARY FUSE (T1)
 - GND GROUND LUGS
 - LT1 RUN PILOT LIGHT
 - LT2 FAULT PILOT LIGHT
 - LVSS EMX4I SOFT STARTER
 - M1 ATL CONTACTOR
 - OLR OVERLOAD RELAY
 - PB1 START PUSHBUTTON
 - PB2 STOP PUSHBUTTON
 - PB3 RESET PUSHBUTTON
 - RLY SS-ATL RELAY CARD
 - SW1 RVSS-ALT SEL. SWITCH
 - SW2 LOCAL-OFF-REMOTE SEL. SWITCH
 - T1 CONTROL POWER TRANSFORMER

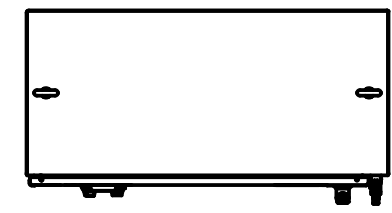
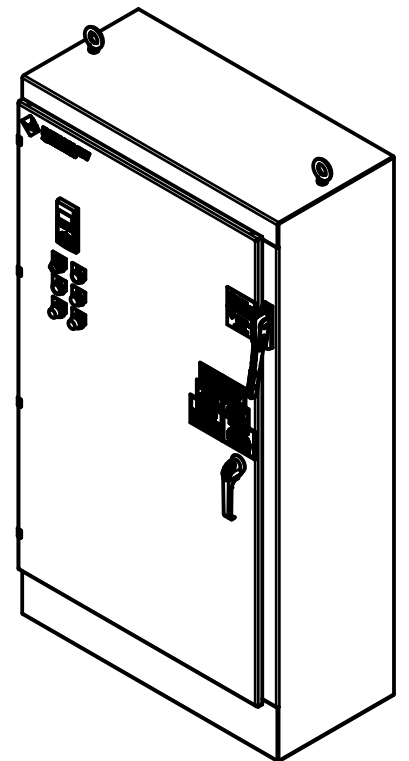

TOP VIEW

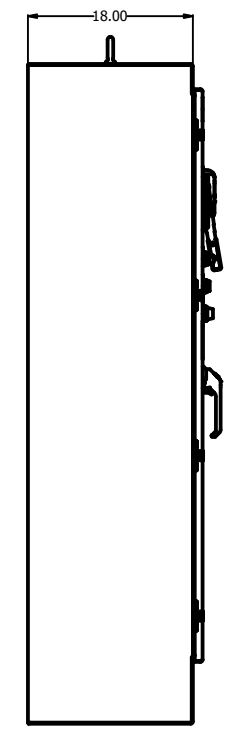

LEFT SIDE

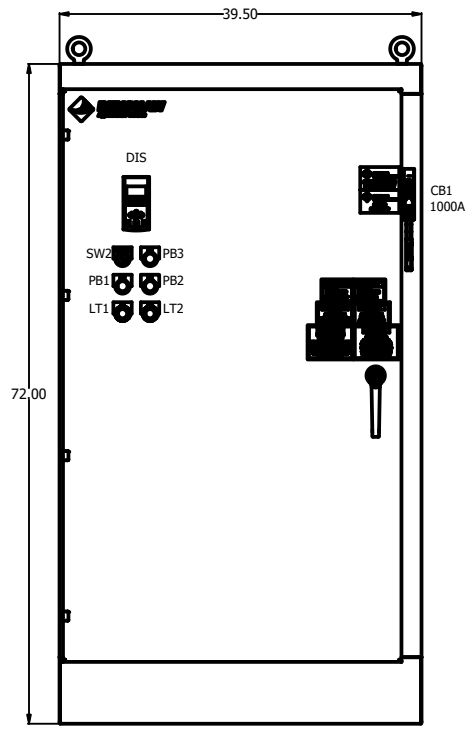

FRONT VIEW

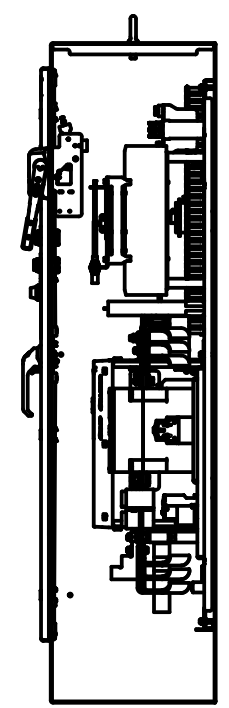

RIGHT SIDE

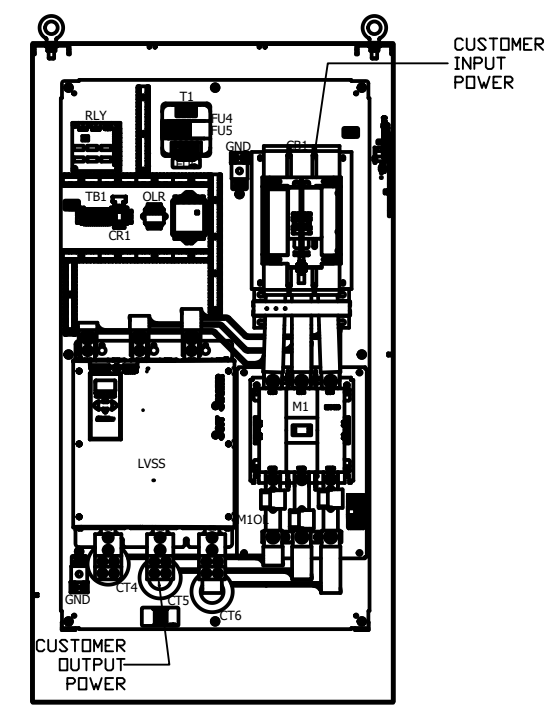

PANEL VIEW

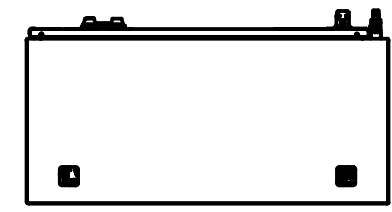

BOTTOM VIEW

APPRD: CHG BY: CHANGE:	REVISIONS DO NOT SCALE DWG	THIRD ANGLE PROJECTION	UNLESS OTHERWISE SPECIFIED ALL DIMENSIONS IN INCHES INTERPRET DRAWING PER ASME Y14.5M-1994	TITLE: OUTLINE RX4E-500-480-3RKP-HB 500HP (590 AMPS) @ 480V (450% CURRENT FOR 30 SECONDS, 125% CONTINUOUS DUTY RATED)	SIGNATURES DRWN: MSN 03/19/21 CHKD: BDA 03/19/21 ENG: MSN 03/19/21 MFG:	DATE 03/19/21 03/19/21 03/19/21	615 ALPHA DRIVE PITTSBURGH, PA. 15238 550 BRIGHT STREET LISTOWEL, ONTARIO M4W 3W3
		THIS DRAWING AND ALL INFORMATION CONTAINED HEREIN, IS THE PROPERTY OF BENSHAW INC. AND MAY NOT BE REPRODUCED, OR DIVULGED TO UNAUTHORIZED PERSONS WITHOUT THE EXPRESS WRITTEN CONSENT OF BENSHAW INC. IT IS PROVIDED SOLELY FOR THE CONVENIENCE OF THE USER AND SHALL BE RETURNED UPON REQUEST.	TOLERANCES: .XX ± .03 .XXX ± .015 ANGLES ± 1°		MATERIAL: FINISH:	SIZE: D DWG NO.: RX4E50048012KPHB REV: 0	
SCALE: 1:1					SHEET 1 OF 3		

RX4E50048012KPHB ON DWG

A
B
C
D
E
F
G
H
I
J
K
L
M
N

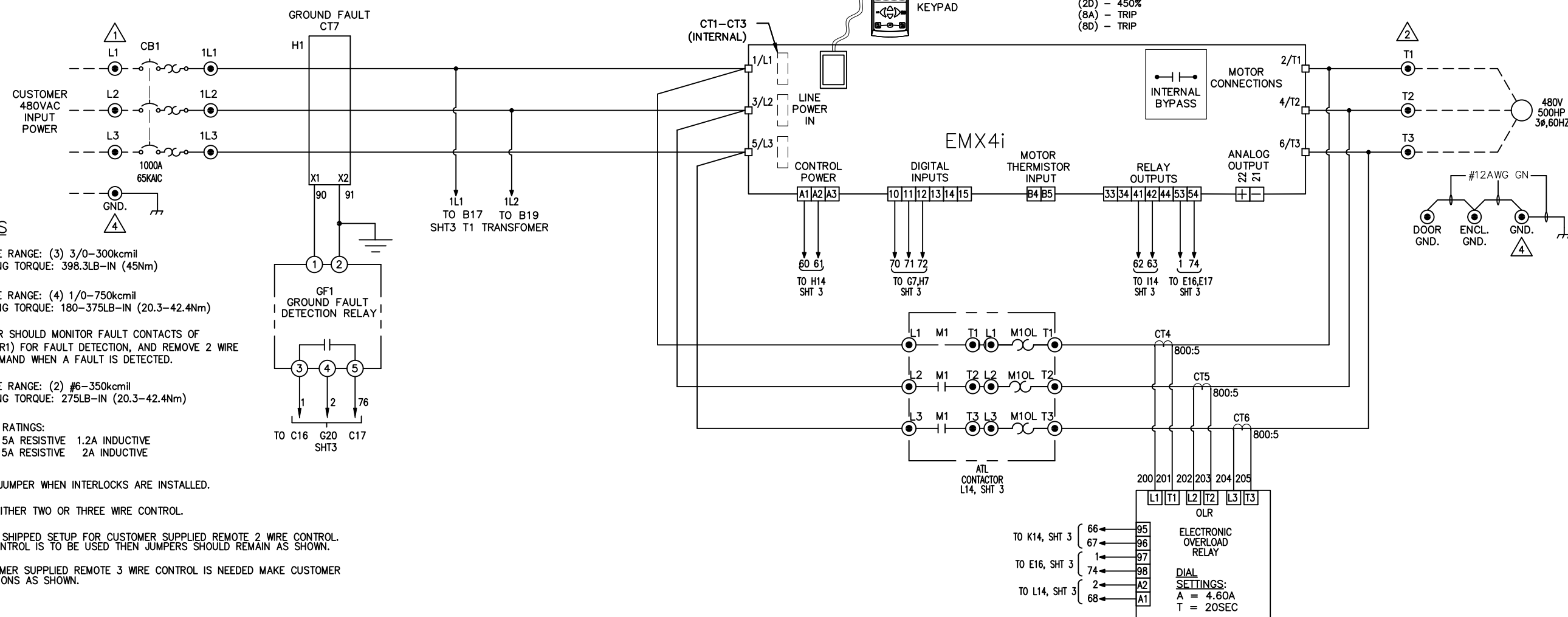

SETTINGS CHANGED DURING FACTORY TESTING:
 (1B) - MOTOR FLA
 (1F) - 125%
 (2D) - 450%
 (8A) - TRIP
 (8D) - TRIP

- NOTES**
- 1 WIRE SIZE RANGE: (3) 3/0-300kcmil
TIGHTENING TORQUE: 398.3LB-IN (45Nm)
 - 2 WIRE SIZE RANGE: (4) 1/0-750kcmil
TIGHTENING TORQUE: 180-375LB-IN (20.3-42.4Nm)
 - 3 CUSTOMER SHOULD MONITOR FAULT CONTACTS OF RELAY (CR1) FOR FAULT DETECTION, AND REMOVE 2 WIRE RUN COMMAND WHEN A FAULT IS DETECTED.
 - 4 WIRE SIZE RANGE: (2) #6-350kcmil
TIGHTENING TORQUE: 275LB-IN (20.3-42.4Nm)
 - 5 CONTACT RATINGS:
240VAC 5A RESISTIVE 1.2A INDUCTIVE
30VDC 5A RESISTIVE 2A INDUCTIVE
 - 6 REMOVE JUMPER WHEN INTERLOCKS ARE INSTALLED.
 - 7 SELECT EITHER TWO OR THREE WIRE CONTROL.
 - 8 STARTER SHIPPED SETUP FOR CUSTOMER SUPPLIED REMOTE 2 WIRE CONTROL. IF NO CONTROL IS TO BE USED THEN JUMPERS SHOULD REMAIN AS SHOWN.
 - 9 IF CUSTOMER SUPPLIED REMOTE 3 WIRE CONTROL IS NEEDED MAKE CUSTOMER CONNECTIONS AS SHOWN.

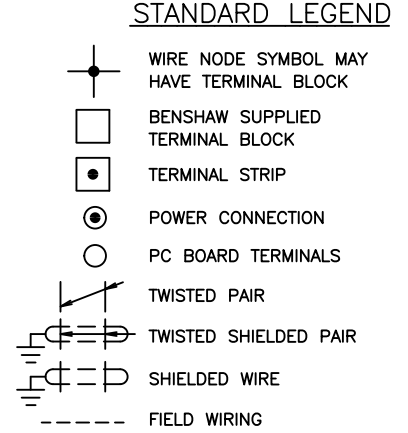
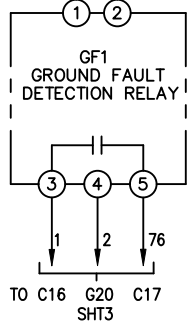

APPRD:	CHG BY:	CHANGE:	REVISIONS	DO NOT SCALE DWG	THIRD ANGLE PROJECTION	UNLESS OTHERWISE SPECIFIED ALL DIMENSIONS IN INCHES INTERPRET DRAWING PER ASME Y14.5M-1994 TOLERANCES: .XX ± .03 .XXX ± .015 ANGLES ± 1°	TITLE: POWER SCHEMATIC RX4E-500-480-12KP-HB 500HP (590 AMPS) @ 480V (450% CURRENT FOR 30 SECONDS, 125% CONTINUOUS DUTY RATED)	SIGNATURES	DATE	<p>615 ALPHA DRIVE PITTSBURGH, PA. 15238 550 BRIGHT STREET LITTONWEL, ONTARIO M4W 3W3</p>
DRWN: MSN	03/19/21	CHKD: BDA	03/19/21	ENGR: MSN	03/19/21	MFR:	SIZE: D	DWG NO.	REV: 0	
<p>THIS DRAWING AND ALL INFORMATION CONTAINED HEREIN, IS THE PROPERTY OF BENSCHAW INC. AND MAY NOT BE REPRODUCED, OR DIVULGED TO UNAUTHORIZED PERSONS WITHOUT THE EXPRESS WRITTEN CONSENT OF BENSCHAW INC. IT IS PROVIDED SOLELY FOR THE CONVENIENCE OF THE USER AND SHALL BE RETURNED UPON REQUEST.</p>								<p>RX4E50048012KPHB</p>		
SCALE: 1:1								SHEET 2 OF 3		

A
B
C
D
E
F
G
H
I
J
K
L
M
N

RX4E50048012KPHB

ON DWG

CUSTOMER SUPPLIED
3 WIRE CONTROL

CUSTOMER SUPPLIED
2 WIRE CONTROL

BIPC-300021-00
RXE RELAY CARD

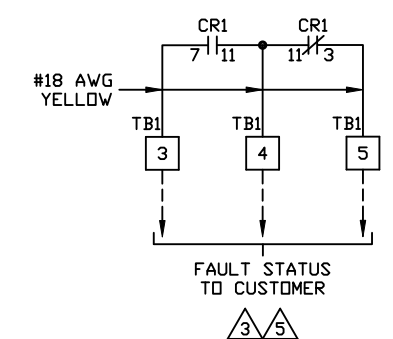
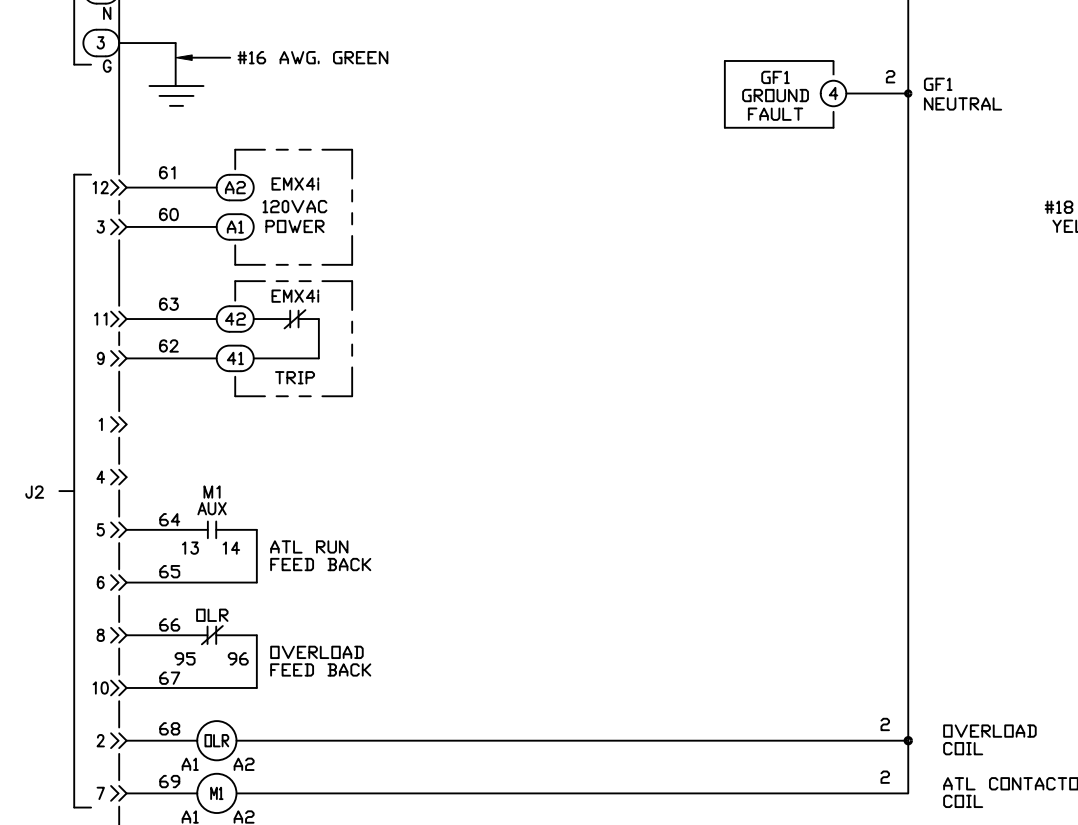
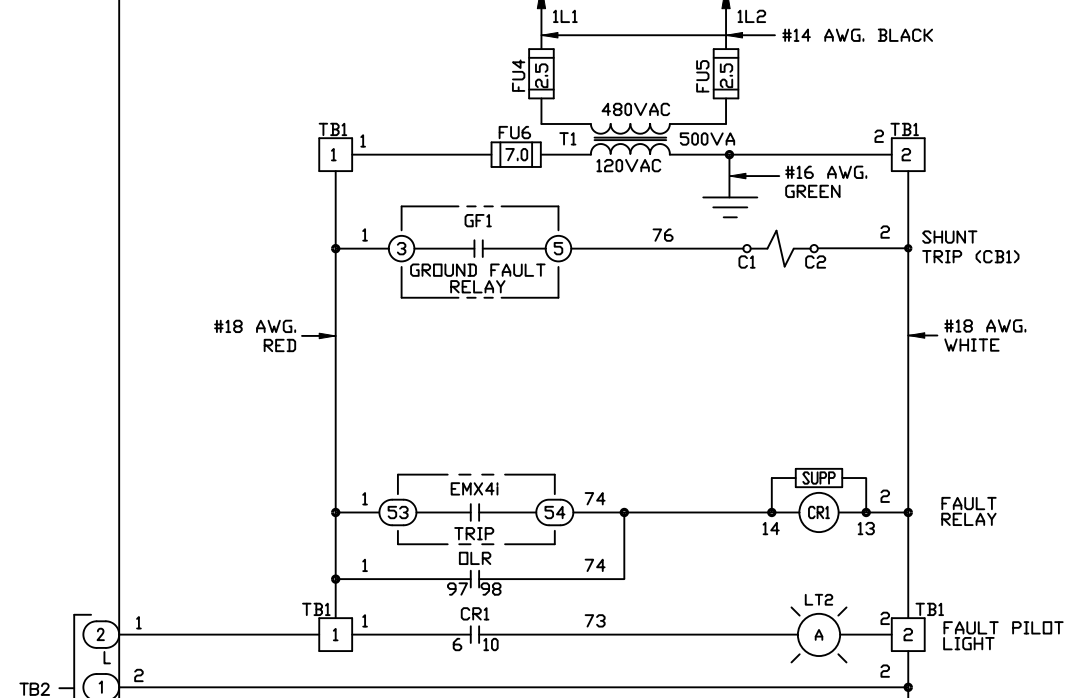
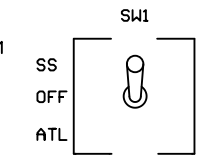
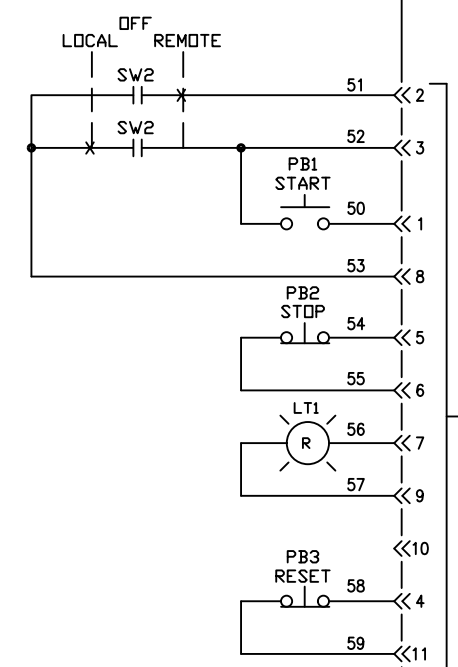
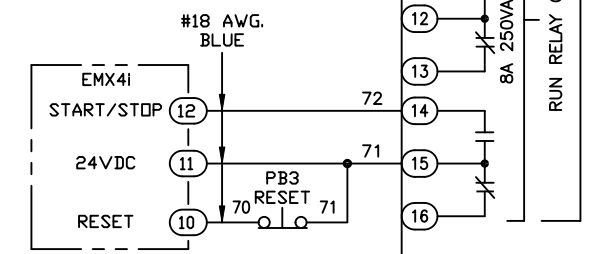
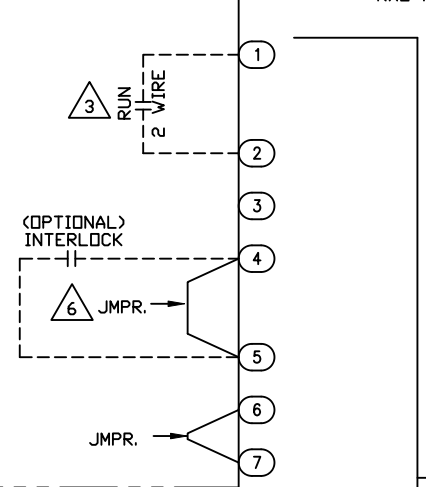
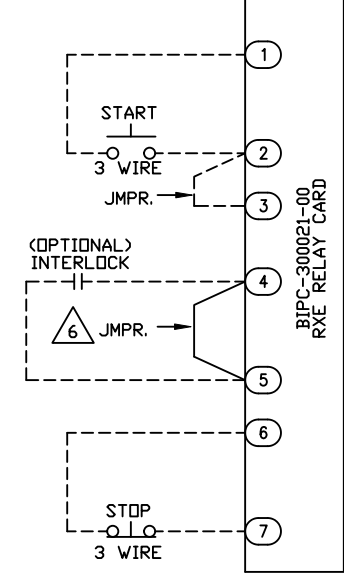

REVISIONS DO NOT SCALE DWG	THIRD ANGLE PROJECTION	UNLESS OTHERWISE SPECIFIED ALL DIMENSIONS IN INCHES INTERPRET DRAWING PER ASME Y14.5M-1994	TITLE: CONTROL SCHEMATIC RX4E-500-480-12KPHB 500HP (590 AMPS) @ 480V (450% CURRENT FOR 30SECONDS, 125% CONTINUOUS DUTY RATED)	SIGNATURES DRWN: MSN 03/19/21 CHKD: BDA 03/19/21 ENG: MSN 03/19/21 MFR:	DATE 03/19/21	615 ALPHA DRIVE PITTSBURGH, PA 15238 550 BRIGHT STREET LISTOWEL, ONTARIO M4W 3W3
	THIS DRAWING AND ALL INFORMATION CONTAINED HEREIN, IS THE PROPERTY OF BENSHAW INC. AND MAY NOT BE REPRODUCED, OR DIVULGED TO UNAUTHORIZED PERSONS WITHOUT THE EXPRESS WRITTEN CONSENT OF BENSHAW INC. IT IS PROVIDED SOLELY FOR THE CONVENIENCE OF THE USER AND SHALL BE RETURNED UPON REQUEST.			SIZE: D DWG NO.: RX4E50048012KPHB	REV: 0	
	TOLERANCES: .XX ± .03 .XXX ± .015 ANGLES ± 1°			MATERIAL:	SCALE: 1:1	
	FINISH:			SHEET 3 OF 3		