

R2LR400-43C

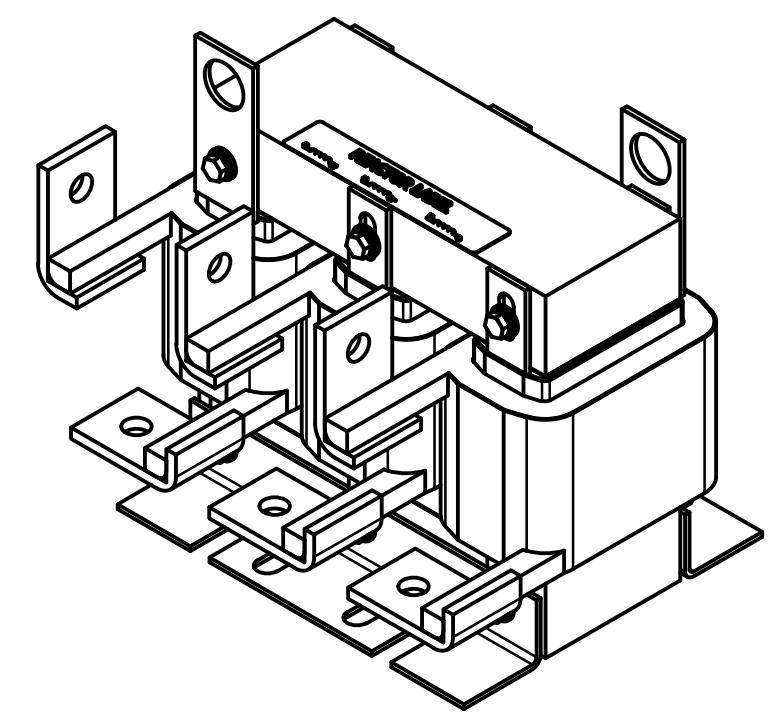

480 V, 600 V Max. Low Z								
Part Number	Horsepower (HP)	Motor Amps (A)	Maximum Amps (A)	Inductance (uH) +/-10%	Weight (lbs)	Losses (W)	Lug Kit	Bus Hole Dia.
R2LR400-43C	400	477	520	37.50	70	470	14	0.53

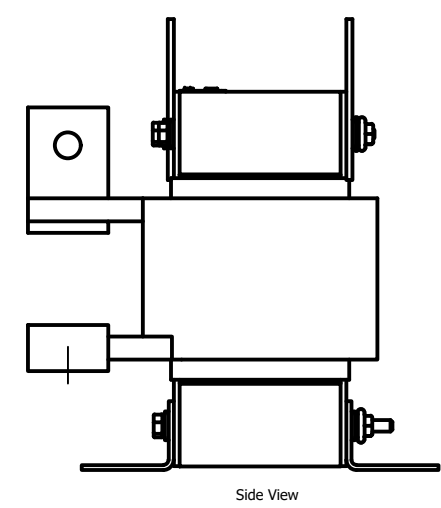
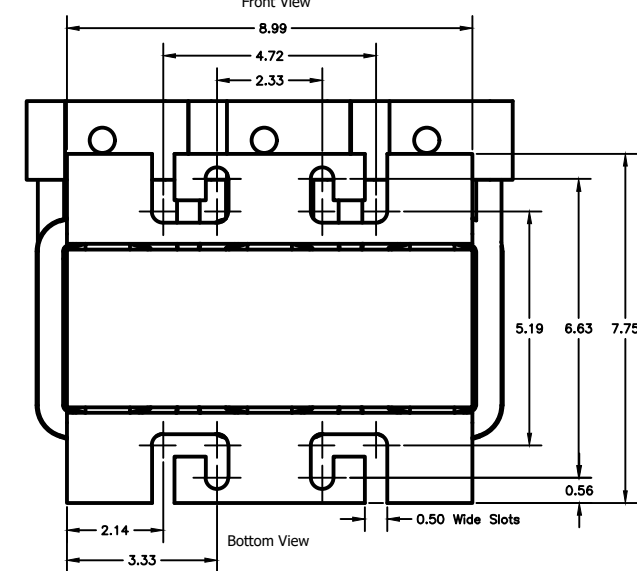
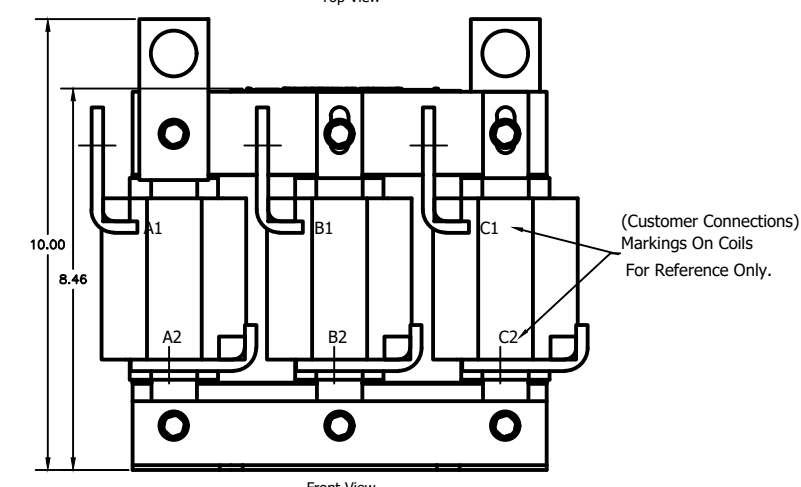
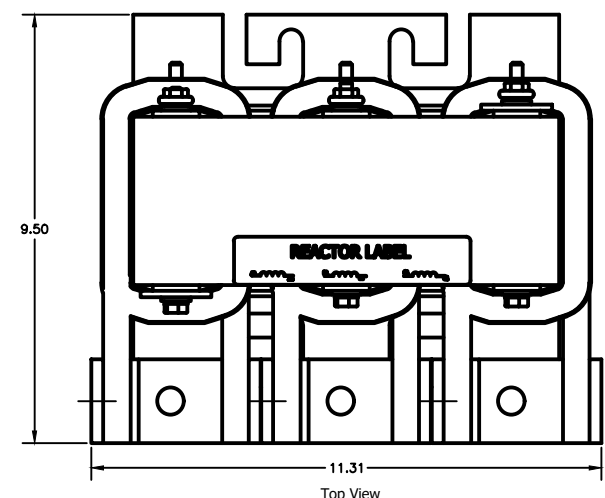
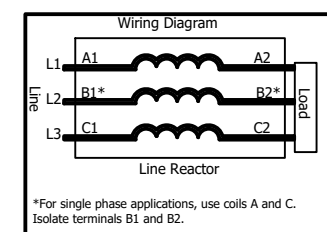

Notes: 1. Installation Instructions: Manual Part Number 890059-00-00.
 2. Customer Is Responsible For Installation To Meet All National And Local Electrical Codes.
 3. Lug Kits sold separately.

REVISIONS DO NOT SCALE DWG	THIRD ANGLE PROJECTION	UNLESS OTHERWISE SPECIFIED ALL DIMENSIONS IN INCHES INTERPRET DRAWING PER ASME Y14.5M-1994 TOLERANCES: .XX ± .03 .XXX ± .015 ANGLES ± 1°	TITLE: LINE REACTOR 3% IMPEDANCE 480V, 400 HP, 477 A OPEN	SIGNATURES DRW: DRP 08/16/22	DATE 08/16/22	615 ALPHA DRIVE PITTSBURGH, PA. 15238 550 BRIGHT STREET LISTOWEL, ONTARIO M4W 3W5		
	THIS DRAWING AND ALL INFORMATION CONTAINED HEREIN IS THE PROPERTY OF BENSHAW INC. AND MAY NOT BE REPRODUCED, OR DIVULGED TO UNAUTHORIZED PERSONS WITHOUT THE EXPRESS WRITTEN CONSENT OF BENSHAW INC. IT IS PROVIDED SOLELY FOR THE CONVENIENCE OF THE USER AND SHALL BE RETURNED UPON REQUEST.			MFG. DATE 08/16/22	SIZE D		DWG NO. R2LR400-43C	REV 0
	SCALE: NTS			SHEET 1 OF 1				