

1 2 3 4 5 6 7 8 9 10 11 12 13 14 15 16 17 18 19 20 21 22 23 24 25 26 27 28

MX4PB-SD-075-2-4-HB
TON DWG

A
B
C
D
E
F
G
H
I
J
K
L
M
N

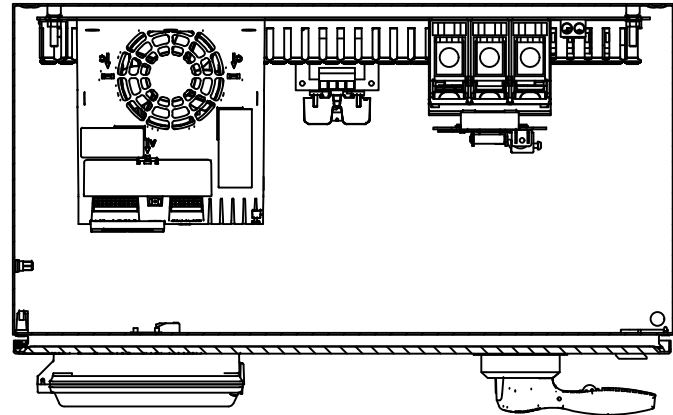

LABEL LEGEND

- CB1: CIRCUIT BREAKER
- GND: GROUND LUG
- LVSS: EMX4I SOFT START (W/INTEGRAL BYPASS)
- TB1: TERMINAL BLOCKS
- CR1-2: CONTROL RELAYS
- T1: CONTROL POWER TRANSFORMER
- FU4-FU5: PRIMARY FUSES (T1)
- FU6: SECONDARY FUSE (T1)
- DIS: EMX4I LCD DISPLAY/KEYPAD

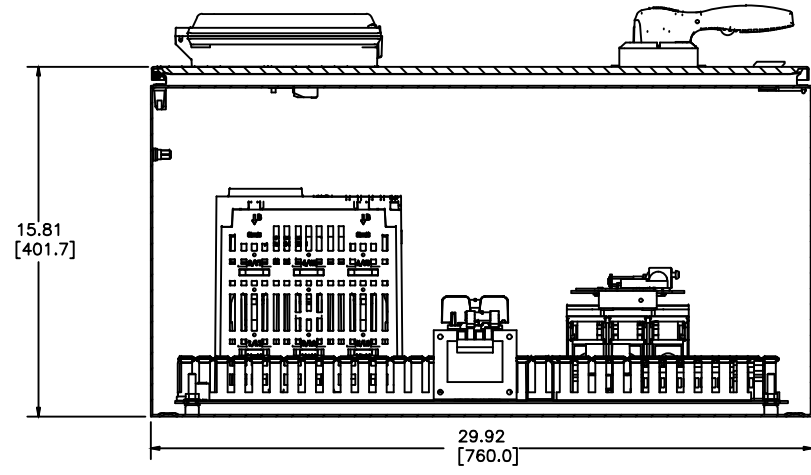
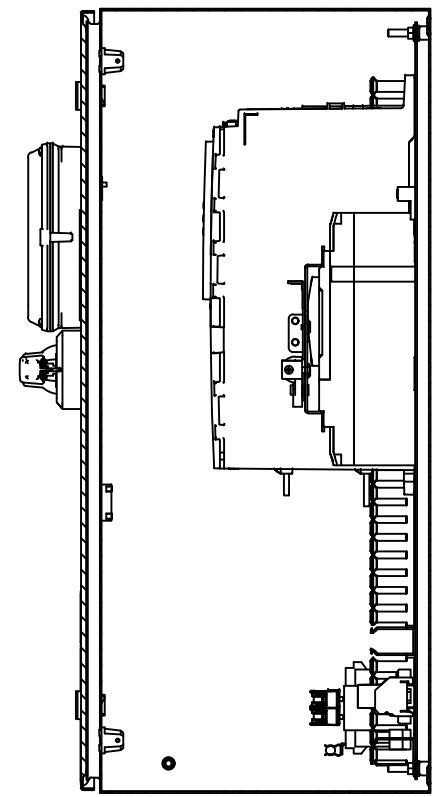
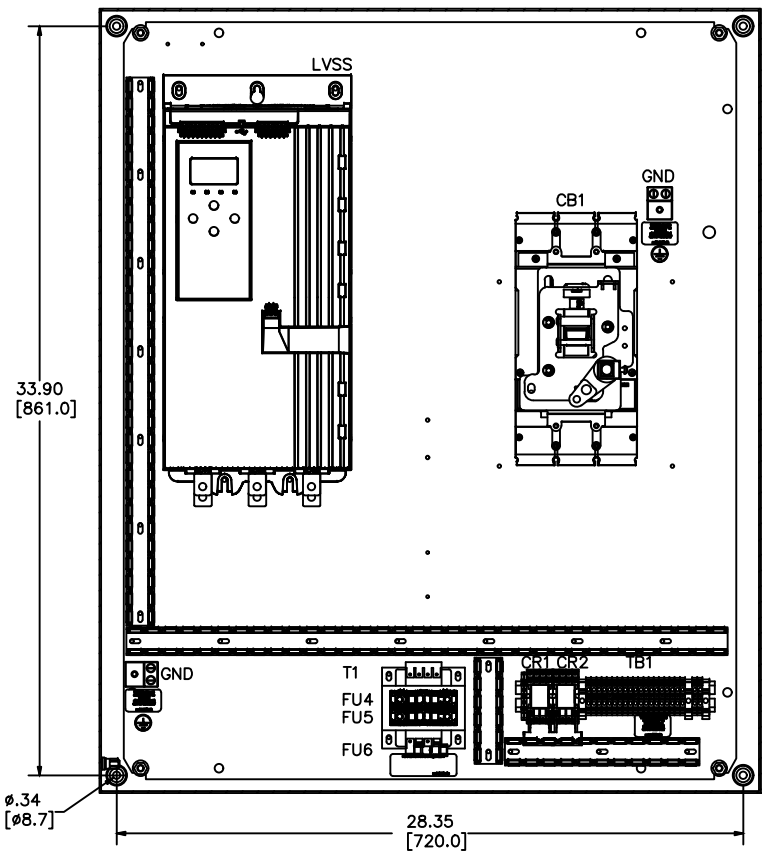
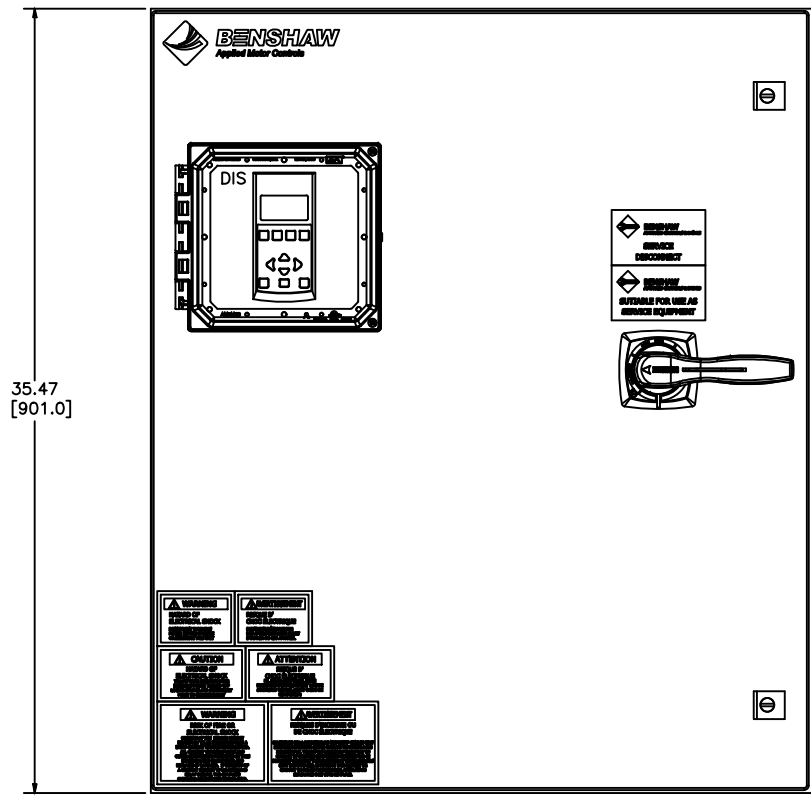

NOTES:

- 1 MINIMUM WIRE BENDING SPACE SHALL BE 8.00" FROM TOP OF CIRCUIT BREAKER POWER CONNECTION TO TOP OF ENCLOSURE.
- 2 ENSURE THAT ALL RIBBON CABLES ARE ROUTED AWAY FROM POWER CONDUCTORS.
- 3 MINIMUM WIRE BENDING SPACE SHALL BE 8.00" FROM BOTTOM OF POWERSTACK POWER CONNECTION TO BOTTOM OF ENCLOSURE.

OPTIONS AND CODE NUMBERS			
OPTION	DISPLAY	HEATER	CONTROL
CODE NO.	YES		

APPRO: BDA 2/8/24	THIRD ANGLE PROJECTION	UNLESS OTHERWISE SPECIFIED ALL DIMENSIONS IN INCHES INTERPRET DRAWING PER ASME Y14.5M-1994 TOLERANCES: .XX ± .03 .XXX ± .015 ANGLES ± 1°
CHG BY: RWS 2/8/24	DO NOT SCALE DWG	
CHANGE CHANGED BRAND OF TERMINAL BLOCKS	THIS DRAWING AND ALL INFORMATION CONTAINED HEREIN IS THE PROPERTY OF BENSCHAW INC. AND MAY NOT BE REPRODUCED OR DIVULGED TO UNAUTHORIZED PERSONS WITHOUT THE EXPRESS WRITTEN CONSENT OF BENSCHAW INC. IT IS PROVIDED SOLELY FOR THE CONVENIENCE OF THE USER AND SHALL BE RETURNED UPON REQUEST.	MATERIAL:

TITLE:
ENCLOSURE LAYOUT
MODULAR REDUCED VOLTAGE
SOLID STATE STARTER
NEMA 4/12 WITH
INTEGRAL BYPASS

SIGNATURES	DATE
DRWN: BDA	3/18/20
CHKD: NMK	3/18/20
ENG: BDA	3/18/20
MFG:	
SIZE	DWG NO.

BENSCHAW
615 ALPHA DRIVE
PITTSBURGH, PA. 15238
550 BRIGHT STREET
LISTOWEL, ONTARIO
M4W 3W5

MX4PB-SD-075-2-4-HB

SCALE: 1:4 SHEET 1 OF 2

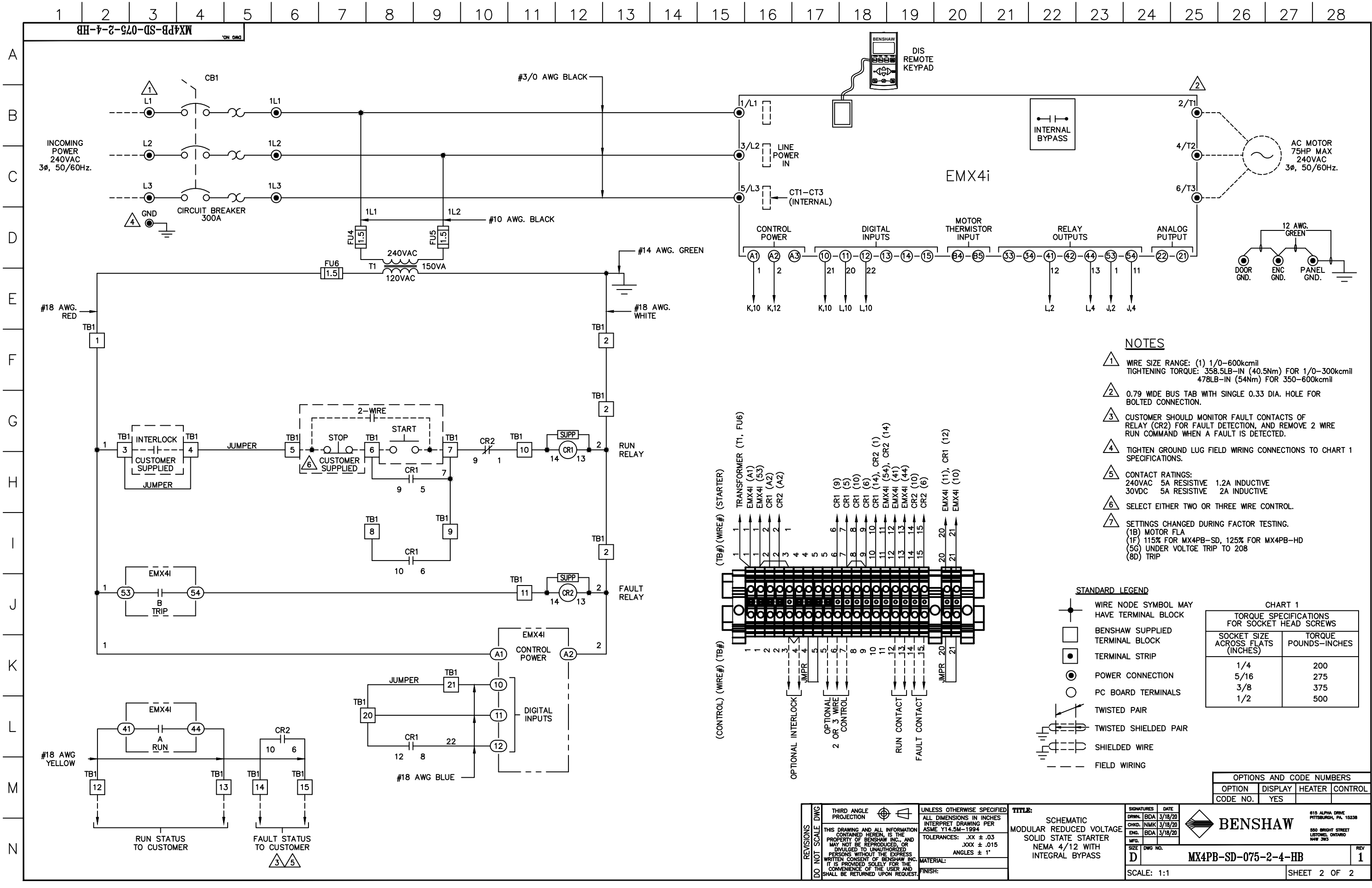

- NOTES**
- 1 WIRE SIZE RANGE: (1) 1/0-600kcmil
TIGHTENING TORQUE: 358.5LB-IN (40.5Nm) FOR 1/0-300kcmil
478LB-IN (54Nm) FOR 350-600kcmil
 - 2 0.79 WIDE BUS TAB WITH SINGLE 0.33 DIA. HOLE FOR BOLTED CONNECTION.
 - 3 CUSTOMER SHOULD MONITOR FAULT CONTACTS OF RELAY (CR2) FOR FAULT DETECTION, AND REMOVE 2 WIRE RUN COMMAND WHEN A FAULT IS DETECTED.
 - 4 TIGHTEN GROUND LUG FIELD WIRING CONNECTIONS TO CHART 1 SPECIFICATIONS.
 - 5 CONTACT RATINGS:
240VAC 5A RESISTIVE 1.2A INDUCTIVE
30VDC 5A RESISTIVE 2A INDUCTIVE
 - 6 SELECT EITHER TWO OR THREE WIRE CONTROL.
 - 7 SETTINGS CHANGED DURING FACTOR TESTING.
(1B) MOTOR FLA
(1F) 115% FOR MX4PB-SD, 125% FOR MX4PB-HD
(5G) UNDER VOLTAGE TRIP TO 208
(8D) TRIP

- STANDARD LEGEND**
- WIRE NODE SYMBOL MAY HAVE TERMINAL BLOCK
 - BENSCHAW SUPPLIED TERMINAL BLOCK
 - TERMINAL STRIP
 - POWER CONNECTION
 - PC BOARD TERMINALS
 - TWISTED PAIR
 - TWISTED SHIELDED PAIR
 - SHIELDED WIRE
 - - - FIELD WIRING

CHART 1
TORQUE SPECIFICATIONS FOR SOCKET HEAD SCREWS

SOCKET SIZE ACROSS FLATS (INCHES)	TORQUE POUNDS-INCHES
1/4	200
5/16	275
3/8	375
1/2	500

OPTIONS AND CODE NUMBERS

OPTION CODE NO.	DISPLAY	HEATER	CONTROL
	YES		

REVISIONS
DO NOT SCALE DWG

THIRD ANGLE PROJECTION

UNLESS OTHERWISE SPECIFIED
ALL DIMENSIONS IN INCHES
INTERPRET DRAWING PER
ASME Y14.5M-1994
TOLERANCES: .XX ± .03
.XXX ± .015
ANGLES ± 1°

MATERIAL:

TITLE:
SCHEMATIC
MODULAR REDUCED VOLTAGE
SOLID STATE STARTER
NEMA 4/12 WITH
INTEGRAL BYPASS

SIGNATURES
DRW: BDA 3/18/20
CHK: NMK 3/18/20
ENG: BDA 3/18/20

DATE
3/18/20

BENSCHAW
615 ALPHA DRIVE
PITTSBURGH, PA. 15238
550 BRIGHT STREET
LISTON, ONTARIO
M4W 3W5

SIZE
D

DWG NO.
MX4PB-SD-075-2-4-HB

REV
1

SCALE: 1:1

SHEET 2 OF 2