



## EMX4 - Advanced Soft Starter



Smart does not have to mean complex. The EMX4 has been designed to make your life easier with an intuitive display and connectivity functions. Access the right information when you need it through the comprehensive graphical display and quick setup menus.

The EMX4 includes starter, motor and system protection functions, complete with alarms to alert you to any potential issues. And for critical must-run applications, the Power Through and Emergency Run function gives you the ability to keep running even if you lose one phase. On-display QR codes allow for fast troubleshooting and support via smartphone.

The built in USB port allows for straightforward upload, download and storage of starter performance information. Optional communications cards enable network connections and more.

There are two models of EMX4 soft starters available: The EMX4i full featured soft starter with ratings up to 1200A or the 'cost optimized' EMX4e model with limited features and ratings (up to 580A).

### EMX4i vs. EMX4e - It's your choice

| Feature Sets                            | EMX4e | EMX4i |
|---|-------|-------|
| <b>MOTOR CONTROL</b>                    |       |       |
| Motor sets                              | 1     | 2     |
| Constant current and current ramp start | •     | •     |
| Adaptive control starting/stopping      | •     | •     |
| Kickstart                               |       | •     |
| Coast to stop and TVR stop              | •     | •     |
| DC brake                                |       | •     |
| Soft brake                              |       | •     |
| Jog (forward and reverse)               |       | •     |
| Inside delta (6 wire) control           |       | •     |
| Soft trip                               | •     | •     |
| Pump clean                              |       | •     |
| Reversing contactor control             |       | •     |
| <b>MOTOR PROTECTION</b>                 |       |       |
| Motor thermistor                        | •     | •     |
| Current imbalance                       | •     | •     |
| Under/Overcurrent                       | •     | •     |
| Under/Overvoltage                       |       | •     |
| Under/Overpower (dry pump protection)   |       | •     |
| Phase sequence (forward/reverse/any)    | •     | •     |
| Phase loss                              | •     | •     |
| Power loss                              | •     | •     |
| Starts per hour limiting                | •     | •     |
| Restart delay (pump back spin delay)    | •     | •     |
| <b>INTEGRATION AND MANAGEMENT</b>       |       |       |
| Multi-language graphical display        | •     | •     |
| Configurable display screen             | •     | •     |
| I/O and network expansion options       | •     | •     |
| USB port and data logging               | •     | •     |
| Analog output                           | •     | •     |
| Emergency run                           | •     | •     |
| Voltage measurement                     |       | •     |
| SCR fail PowerThrough operation         |       | •     |
| Daily on/off scheduling                 |       | •     |
| Run timer mode (on/off cycle timer)     |       | •     |
| Run simulation                          | •     | •     |





## Ratings

|             | Standard<br>350%, 30 s, 4 starts per hour |                |                |                | Heavy<br>450%, 30 s, 4 starts per hour |                |                |                | Dimensions          |                    |                    |                   |
|-------------|---|----------------|----------------|----------------|--|----------------|----------------|----------------|---------------------|--------------------|--------------------|-------------------|
|             | A   | HP @230<br>VAC | HP @460<br>VAC | HP @575<br>VAC | A                                      | HP @230<br>VAC | HP @460<br>VAC | HP @575<br>VAC | Height<br>inch (mm) | Width<br>inch (mm) | Depth<br>inch (mm) | Weight<br>lb (kg) |
| EMX4i-0024B | 17  | 5              | 10             | 15             | 14                                     | 3              | 10             | 10             | 13.2<br>(336)       | 6.0<br>(152)       | 9.1<br>(231)       | 10.7<br>(4.8)     |
| EMX4i-0042B | 28  | 10             | 20             | 25             | 22                                     | 7.5            | 15             | 20             |                     |                    |                    |                   |
| EMX4i-0052B | 35  | 10             | 25             | 30             | 28                                     | 10             | 20             | 25             |                     |                    |                    |                   |
| EMX4i-0064B | 52  | 15             | 30             | 40             | 40                                     | 10             | 25             | 30             |                     |                    |                    |                   |
| EMX4i-0069B | 59  | 20             | 40             | 50             | 46                                     | 15             | 30             | 40             | 19.5<br>(495)       | 8.5<br>(216)       | 9.6<br>(243)       | 10.9<br>(4.9)     |
| EMX4i-0105B | 77  | 25             | 50             | 60             | 52                                     | 15             | 40             | 50             |                     |                    |                    |                   |
| EMX4i-0115B | 81  | 30             | 60             | 75             | 65                                     | 20             | 50             | 60             |                     |                    |                    |                   |
| EMX4i-0135B | 99  | 30             | 75             | 100            | 77                                     | 25             | 60             | 75             |                     |                    |                    |                   |
| EMX4i-0184B | 124                                       | 40             | 75             | 100            | 96                                     | 30             | 60             | 75             | 20.6<br>(523)       | 17.6<br>(446)      | 12.2<br>(310)      | 12.1<br>(5.5)     |
| EMX4i-0200B | 131                                       | 50             | 100            | 125            | 104                                    | 40             | 75             | 100            |                     |                    |                    |                   |
| EMX4i-0229B | 156                                       | 60             | 125            | 150            | 124                                    | 40             | 100            | 100            |                     |                    |                    |                   |
| EMX4i-0250B | 195                                       | 75             | 150            | 200            | 156                                    | 60             | 125            | 150            |                     |                    |                    |                   |
| EMX4i-0352B | 240                                       | 75             | 150            | 200            | 180                                    | 60             | 150            | 150            | 24.3<br>(618)       | 17.6<br>(446)      | 12.2<br>(310)      | 34.2<br>(15.5)    |
| EMX4i-0397B | 261                                       | 100            | 200            | 250            | 203                                    | 75             | 150            | 200            |                     |                    |                    |                   |
| EMX4i-0410B | 377                                       | 150            | 300            | 350            | 302                                    | 100            | 250            | 300            |                     |                    |                    |                   |
| EMX4i-0550B | 414                                       | 150            | 350            | 450            | 321                                    | 125            | 250            | 300            |                     |                    |                    |                   |
| EMX4i-0580B | 477                                       | 200            | 400            | 500            | 361                                    | 150            | 300            | 350            | 24.3<br>(618)       | 17.6<br>(446)      | 12.2<br>(310)      | 41.9<br>(19.0)    |
| EMX4i-0835B | 515                                       | 200            | 450            | 500            | 414                                    | 150            | 350            | 450            |                     |                    |                    |                   |
| EMX4i-0940B | 590                                       | 200            | 500            | 600            | 480                                    | 200            | 400            | 500            |                     |                    |                    |                   |
| EMX4i-1070B | 796                                       | 300            | 600            | 800            | 619                                    | 250            | 500            | 600            |                     |                    |                    |                   |
| EMX4i-1230B | 984                                       | 400            | 800            | 1000           | 768                                    | 300            | 600            | 800            | 24.3<br>(618)       | 17.6<br>(446)      | 12.2<br>(310)      | 112.4<br>(51)     |
| EMX4i-1250B | 1130                                      | 450            | 900            | 1100           | 903                                    | 350            | 700            | 900            |                     |                    |                    |                   |

\* EMX4e available only up to -0580 model

## Smart Card Technology

The EMX4i Smart Card redefines the role of a soft starter. With the appropriate Smart Card installed the EMX4i is able to operate as an entire system controller. Smart Cards deliver industry or application specific functionality and are easily inserted into the EMX4i, simplifying system design, installation and set-up.



## Part Number Selection

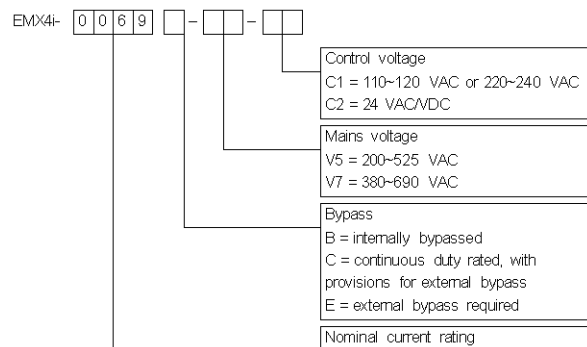

\* See user manual or catalog for 'C' and 'E' model max amp ratings

**Benshaw, Inc.**  
615 Alpha Drive, Pittsburgh, PA 15238, United States  
Phone: 412.968.0100

**Benshaw Canada Controls, Inc.**  
550 Bright Street East, Listowel, Ontario N4W 3W3, Canada  
Phone: 519.291.5112