



Quick Start Guide

RSi “S” Series VFD

Using the 7-segment (4 digit LED) Keypad/Display

Contents

1. Display and Keypad Buttons - Operation.....	2
2. Wiring.....	3
A. Power Terminals	3
B. Control Terminals.....	3
3. Quick Start Parameters	4
A. Control (Start/Stop)	4
B. Speed Reference	4
C. Motor Parameters.....	4
D. Protection Parameters.....	4
4. Control and Speed Reference Settings - Detail.....	5
5. Faults and Warnings.....	6
A. Voltage and Current Faults	6
B. Drive Faults	7
C. External Input Faults	7
D. Communication Faults	7
E. Warnings	8

This guide contains basic parameter settings for control and protection of a standard induction motor when using the 7-segment (4 digit LED) keypad that comes mounted on the drive. The default settings are used for a standard induction motor controlled with a linear (fixed) V/Hz. pattern with a base frequency of 60 Hz.



1. Display and Keypad Buttons - Operation

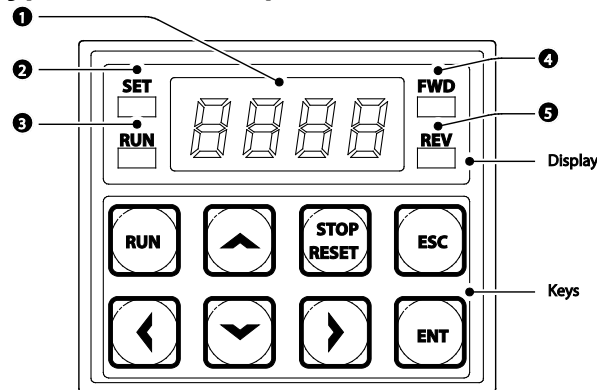

No.	Name	Description
①	7-Segment (LED) Display	Displays running speed (Hz. default), operational status, parameters (codes), parameter choices and Fault Codes.
②	SET Indicator	LED turns on when in program (set) mode (see ENT button). Flashes when the ESC key operates as the multi-function key.
③	RUN Indicator	LED turns on during running. Flashes during speed changes (acceleration and deceleration).
④	FWD Indicator	LED turns on during forward operation.
⑤	REV Indicator	LED turns on during reverse operation.

Pushbutton	Name	Description
	[RUN] button	Press to start/run the inverter when set to Keypad control.
	[STOP/RESET] button	STOP: Stops the inverter when set to Keypad control. Note: When using remote keypad (LCD), the Stop button is not active. RESET: Resets the inverter following fault condition.
	[▲] Up button, [▼] Down button	Move between parameters (codes) within a group. When in program (set) mode, increase or decrease parameter values/settings.
	[◀] Left button [▶] Right button	Move between parameter groups. Move the cursor when in program (set) mode.
	[ENT] button	Press ENT to enter the program (set) mode of the displayed parameter. After making changes, Press ENT twice to confirm parameter changes.
	[ESC] button	A multi-function button used to configure different functions, such as: <ul style="list-style-type: none"> • Cancellation of a parameter setting • Jog operation • Remote/Local mode switching

2. Wiring

A. Power Terminals

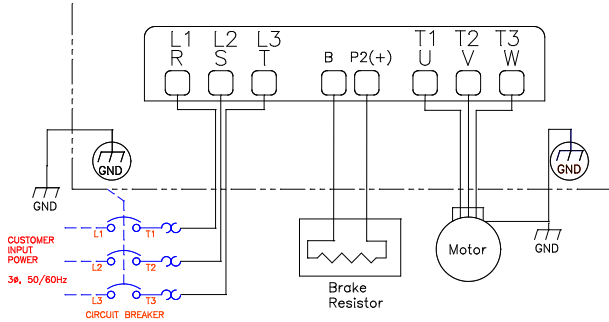

Recommended Wire Sizes Power, Ground and Control Wiring					
Voltage	HP	Power		Ground	Control
		AWG	AWG	AWG	AWG
		R/S/T	U/V/W		
240V	1	14	14	12	18
	2				
	3				
	5	12	12	10	
	7.5	10	10	10	
	10	8	8	6	
480V	1	14	14	12	18
	2				
	3				
	5	12	12	12	
	7.5	10	10	10	
	10	8	8	8	
Cable Spec		Copper, 600V, 75C			300V, 75C
Torque (max) in-lbs		5.3			2.2

B. Control Terminals

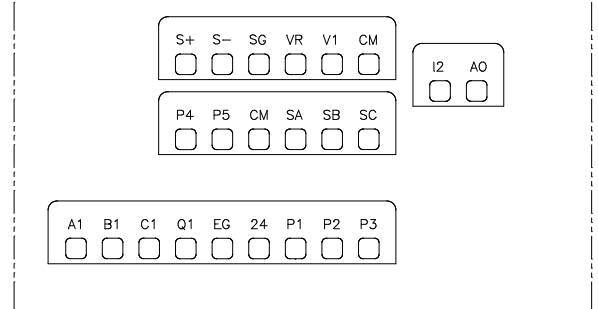

Control Terminals				
Terminal	Function	Parameter	Setting	
P1	Start Forward	In.65	1:Fx	
P2	Start Reverse	In.66	2:Rx	
P3	Output Disable	In.67	5:BX	
P4	Reset	In.68	3:RST	
P5	Low Speed	In.69	7:Sp-L	
CM	Common	-	-	
VR	10VDC Supply	-	-	
V1	0-10VDC Speed Ref.	dr.07	2:V1	
CM	Common	-	-	
I2	4-20mA Speed Ref.	dr.07	5:I2	
A1	Relay NO	Ou.31	29:Trip	
B1	Relay NC			
C1	Common			
P24	24VDC Supply	For Q1	-	
Q1	Open Collector Output	Ou.33	14:Run	
EG	Ground	For Q1	-	
S+	Communications RS-485 (Modbus)	CM.01 - CM.05	0: Modbus RTU	
S-				
SG				
AO	Analog Output	Ou.01	0:Freq	
CM				
SA	STO Safe Torque Off	-	-	
SB		-	-	
SC		-	-	





3. Quick Start Parameters

A. Control (Start/Stop)

B. Speed Reference

C. Motor Parameters

D. Protection Parameters

				Settings		
				Option #	Desc.	
Function	Group	Parameter	Range		Default	
A	Control (Start/Stop)	Operations (Main)	drv	0	Keypad	1:Fx/Rx-1
				1	Fx/Rx-1	
				2	Fx/Rx-2	
B	Speed Reference	Operations (Main)	Frq	0	Keypad-1	0: Keypad-1
				1	Keypad-2	
				2	V1	
				4	V2	
				5	I2	
C	Motor Parameters					
Load Type / Duty (Normal/Heavy)	Pr	04	0	Normal Duty	1: Heavy Duty	
			1	Heavy Duty		
Motor Capacity	dr	14	0	0.3 HP	Varies with Drive Rating	
			1	0.5 HP		
			2	1.0 HP		
			3	1.5 HP		
			4	2.0 HP		
			5	3.0 HP		
			6	4.0 HP		
			7	5.0 HP		
			8	5.5 HP		
			9	7.5 HP		
			10	10 HP		
11	15 HP					
Motor Poles	bA	11	2 ~ 48		Dependent on motor setting	
Slip		12	0-3000(Rpm)			
Motor FLA (rated current)		13	1.0-1000.0(A)			
Motor No Load Current		14	0.0-1000.0(A)			
Motor Rated Voltage	15	170-480(V)		230/460		
Motor Efficiency	16	64-100(%)		Dependent on motor setting		
AC Input Voltage (Source)	19	170-480(V)		240/480		
Motor Direction	Ad	09	0	None	0: None	
			1	Forward Prev		
			2	Reverse Prev		
D	Protection Parameters					
Input/Output Phase Loss Protection	Pr	05	0	Off	00 Displayed as:	11 as:
			1	On	 Off/Off	 On/On
Overload	Pr	20	0	None	1: Free-Run	
			1	Free-Run		
			2	Dec		
Trip Level	21	30-200(%)		180		
Trip Time	22	0.0-60.0(s)		60		
ETH (Electronic Thermal Overload)	Pr	40	0	None	0:None	
			1	Free-Run		
			2	Dec		
Motor Cooling Type	Pr	41	0	Self-cool	0:Self-cool	
			1	Forced-cool		
ETH (1 minute)	42	120-200(%)		150		
ETH (Continuous)	43	50-150(%)		120		



4. Control and Speed Reference Settings - Detail

Start/Stop Keypad				
Terminal	Function	Parameter	Setting	
-	Command Source	drv	0	Keypad
Press RUN button (green) to start. Press STOP/RESET button (red) to stop. See parameter drC to change direction.				

2-Wire Start/Stop Control				
Terminal	Function	Parameter	Setting	
	Command Source	drv	1	Fx/Rx-1
P1	Start Forward	In.65	1	Fx
P2	Start Reverse	In.66	2	Rx
CM	Common	-	-	-

3-Wire Start Stop Control				
Terminal	Function	Parameter	Setting	
	Command Source	drv	1	Fx/Rx-1
P1	Start Forward	In.65	1	Fx
P2	Start Reverse	In.66	2	Rx
P3	3-Wire	In.67	14	3-Wire
CM	Common	-	-	-

Hand - Off - Auto Local - Off - Remote				
Terminal	Function	Parameter	Setting	
P3	Hand/Auto	In.67	15	2nd Source
CM	Common			
Hand Mode				
-	Command Source	drv	0	Keypad
			1	Fx/Rx-1
			2	Fx/Rx-2
-	Speed Reference	Frq	0	Keypad-1
			1	Keypad-2
			2	V1
			4	V2
			5	I2
Auto Mode				
-	Cmd Aux (2nd) source	bA.01	0	Keypad
			1	Fx/Rx-1
			2	Fx/Rx-2
-	Frq Aux (2nd) source	bA.02	0	Keypad-1
			1	Keypad-2
			2	V1
			4	V2
			5	I2
With P3 Input Open - VFD uses drv and Frq settings				
With P3 Input Closed - VFD uses bA.01 and bA.02 settings				

Speed Reference Keypad				
Terminal	Function	Parameter	Setting	
-	Freq. Ref. Source	Frq	0	Keypad-1
Program the speed (frequency) at the main screen (0.00)				

Speed Reference 4 - 20 mA Input				
Terminal	Function	Parameter	Setting	
I2	4-20mA Speed Ref.	Frq	5	I2
CM	Common	-	-	-
	View Input Signal	In.50	View Only	
	Filter Time	In.52	10	msec
Scaling of 4-20mA signal	Min. Input	In.53	4.0	mA
	Output (%) at Min. Input	In.54	0.0	%
	Max. Input	In.55	20.00	mA
	Output (%) at Max. Input	In.56	100	%
	I2 Inverting	In.61	0	No

Speed Reference 0 - 10 VDC (Potentiometer)				
Terminal	Function	Parameter	Setting	
VR	VDC Supply	-	-	-
V1	0-10VDC Input	Frq	2	V1
CM	Common	-	-	-
	View Input Signal	In.05	View Only	
	Filter Time	In.07	10	msec
Scaling of 0-10V signal	Min. Input	In.08	0	V
	Output (%) at Min. Input	In.09	0	%
	Max. Input	In.10	10	V
	Output (%) at Max. Input	In.11	100	%
	V1 Inverting	In.16	0	No

5. Faults and Warnings

There are 3 levels of **Fault** conditions in addition to **Warning** messages.

- **Non-Latched Faults:** Do not require a Reset. When the fault is corrected, the fault or warning message disappears. The fault is not saved in the fault history.
- **Latched Faults:** Require a reset (keypad or external). When the fault is corrected and reset, the fault disappears. The fault is saved in the fault history.
- **Fatal:** Drive requires power to be cycled Off then On.

Faults are stored and can be viewed at Pr.g1 through Pr.g5. When more than 1 fault occurs at the same time, the keypad displays the higher priority fault.

- **Warnings:** To be displayed, all warning messages have to be enabled with the associated parameters, except IOLW (Inverter Overload Warning). The most recent warning message can be viewed at Pr.g0.

A. Voltage and Current Faults

Display	Fault	Type	Description	Related Parameters
OLt	Over Load	Latch	Motor Overload. Motor current exceeds the set overload levels. Activated when Pr.20 is set to 1 or 2 and the output current has exceeded the Pr.21 level (%) for longer than the Pr.22 time (secs.).	Pr.04, bA.13, Pr.20, Pr.21, Pr.22
ULt	Under Load	Latch	Motor Underload. Motor current is less than the set underload levels. Activated when Pr.27 is set to 1 or 2 and the output current is lower than the Pr.30 level (%) for longer than the Pr.28 time (secs.). Active when the motor speed above twice the motor slip speed (freq.) bA.12.	bA.13, Pr.27, Pr.28, Pr.29, Pr.30
OCt	Over Current1	Latch	Inverter Over Current-1. Output current exceeded 200% of the rated current.	-
OC2	Over Current2	Latch	Inverter Over Current-2. Excessive output current indicating a short circuit condition.	-
Out	Over Voltage	Latch	Over Voltage. Internal DC bus voltage exceeded the trip level.	-
Lut	Low Voltage	Non-Latched	Low Voltage. Internal DC bus voltage is less than the trip level.	bA.19, Pr.81
Lu2	Low Voltage2	Latch	Low Voltage-2. Internal DC bus voltage is less than the trip level.	bA.19, Pr.82
GFt	Ground Trip*	Latch	Ground Fault. Ground current exceeds a fixed value, varies with inverter capacity (~30% for 30 msecs.).	-
EtH	E-Thermal	Latch	Electronic Thermal Overload. Inverter has predicted a rise in motor temperature. Activated when Pr.40 is set to 1 or 2 and the output current has exceeded the Pr.42 or Pr.43 levels (%). Common Fault during low speed (<20 Hz.) operation.	bA.13, Pr.40, Pr.41, Pr.42, Pr.43
POT	Output Phase Open	Latch	Output Phase Open. Current in one or more phases is less than 15% of inverter rated current. Activated when Pr.05 is set to 01.	Pr.05
IPO	Input Phase Open	Latch	Input Phase Open. DC Bus ripple voltage is higher than normal indicating a missing input phase.. Activated when Pr.05 is set to 10.	Pr.05, Pr.06
IOL	Inverter OLT	Latch	Inverter Overload. Output current has exceeded the Inverter rated current. Overload ratings for the inverter are 150% for 1 min and 200% for 4 sec.	-
nMt	No Motor Trip	Latch	Low Current Fault. Activated when Pr.31 is set to 1 and the output current is below the Pr.32 level (%) for the Pr.33.time (secs.).	bA.13, Pr.31, Pr.32, Pr.33

* Ground Fault monitoring is not supported inverters 5.0 HP and lower. An over voltage Fault (ovt) or over current Fault (OCT) will occur.



B. Drive Faults

Display	Fault	Type	Description	Related Parameters
Oht	Over Heat	Latch	Inverter Over Heat. Inverter heat sink temperature exceeded 110°C.	-
HWt	H/W-Diag Trip	Fatal	Hardware diagnostic Fault. Error detected in the Inverter Control Board. Areas monitored are memory (EEPROM), analog-digital converter output (ADC Off Set), or CPU watchdog (Watch Dog-1, Watch Dog-2). EEP Err: An error occurred in reading/writing parameters due to keypad or memory (EEPROM) Fault. ADC Off Set: An error in the current sensing circuit (U/V/W terminal, current sensor, etc.).	-
FAn	Fan Trip	Latch	Cooling Fan Fault. Inverter detected an issue with the cooling fan. Activated when Pr.79 is set to 0 (zero).	Pr.79

C. External Input Faults

Display	Fault	Type	Description	Related Parameters
Ext	External Trip	Latch	External Fault. Input signal at terminal Px set to (4) External Trip is activated.	In.65 - In.69
bx	Inverter Output disabled (blocked)	Non-Latched	BX Fault, Inverter Disabled. Input signal at terminal Px set to (5) BX is activated.	In.65 - In.69
ntC	NTC Open	Latch	Internal Temperature Sensor Fault. Temperature sensor of the Insulated Gate Bipolar Transistor (IGBT) is open or sensing below 10°C.	-
Pid	Pre-PID Fail	Latch	In Pre-PID mode, PID feedback is measured below the AP.35 level (%) for longer than the AP.36 Pre-PID time (secs.).	AP.34, AP.35, AP.36
xbr	Ext-Brake	Latch	When using External Brake Control, the Inverter output starting current remained below the value set at Ad.41, Brake Open Current.	Ad.41, Ad.42
SFA/SFb	Safety A(B) Err	Latch	Safe Torque Off Fault. One of the two safety (STO) input terminals (SA, SB, SC) is open.	-

D. Communication Faults

Display	Fault	Type	Description	Related Parameters
LOr	Lost Command or Reference	Non-Latched	Lost Command Source (Start/Stop control): Lost command over communications (RS-485 and other network options). Lost Frequency Reference Source (Speed control): Lost speed reference via analog or communications.	Pr.12, Pr.13, Pr.14, Pr.15
IOt	IO Board Trip	Latch	Control board (I/O board) or external communication card is not connected to the inverter.	-
ErrC			Displayed when the error code continues for more than 5 sec. Displayed as: ('Errc' -> '-rrc' -> 'Er-c' -> 'Err-' -> '-rc' -> 'Er-' -> '- - - -' -> 'Errc' -> ...)	
PAr	ParaWrite Trip	Latch	Parameter Writing Error when using remote display (LCD). Displayed when communication fails during parameter writing due to a control cable Fault or a bad connection.	-
OPt	Option Trip-1	Latch	Option Board Fault. Error is detected between the inverter and the communication board.	-



E. Warnings

Display	Warning	Type	Description	Related Parameters
OLW	Over Load	Warning	Motor Overload Warning. Activated when Pr.17 (overload warning) is set to 1 and the motor current is above the Pr.18 level (%) for longer than the Pr.19 time (secs.). One of the digital output terminals (Relay 1 or Q1) can be set to 5 (Over Load) to output the warning.	Pr.04, Pr.17, Pr.18, Pr.19, OUT.31, OUT.33
ULW	Under Load	Warning	Motor Underload Warning. Activated when Pr.25 is set to 1 and the output current is lower than the Pr.30 level (%) for longer than the Pr.26 time (secs.). One of the digital output terminals (Relay 1 or Q1) can be set to 7 (Under Load) to output the warning.	bA.13, Pr.04, Pr.25, Pr.26, OUT.31, OUT.33
IOLW	INV Over Load	Warning	Inverter Overload Warning. Displayed after 36 secs. of a 150% overload. One of the digital output terminals (Relay 1 or Q1) can be set to 6 (IOL) to output the warning.	OUT.31, OUT.33
LCW	Lost Command or Reference	Warning	Lost Command Warning: Lost RS-485 communications at the terminal block (Start/Stop or Speed Reference) or lost analog speed reference based on the conditions set at Pr.13- 15. Warning occurs even with Pr.12 set to 0. Applies to both Start/Stop control (when over communications) and Speed Reference via analog or communications. One of the digital output terminals (Relay 1 or Q1) can be set to 13 (Lost Command) to output the warning.	Pr.12, Pr.13, Pr.14, Pr.15
FAnW	Fan Warning	Warning	Cooling Fan Warning. Activated when Pr.79 is set to 1. One of the digital output terminals (Relay 1 or Q1) can be set to 8 (Fan Warning) to output the warning.	Pr.79, OUT.31, OUT.33
dbW	DB Warn %ED	Warning	Dynamic Brake Warning. DB resistor usage rate exceeds the set percentage.	Pr.66
trtr	Retry Tr Tune	Warning	Sensorless Auto Tuning warning. The warning occurs when the motor's rotor time constant (Tr) is either too low or too high.	DRV.09, bA.20