

**Operating Parameters**

Parameter	Description	Default	Units	
LED	LCD			
<b>P1</b>	<b>QST 01</b>	<b>Motor Full Load Amps</b>	<b>10</b>	<b>RMS Amps</b>
<b>P2</b>	<b>QST 02</b>	<b>Motor Service Factor</b>	<b>1.15</b>	
<b>P3</b>	<b>QST 03</b>	<b>Motor Running Overload Class</b>	<b>10</b>	
<b>P4</b>	<b>QST 04</b>	<b>Local Source</b>	<b>tEr</b>	
<b>P5</b>	<b>QST 05</b>	<b>Remote Source</b>		
<b>P6</b>	<b>QST 06</b>	<b>Initial Motor Current 1</b>	<b>100</b>	<b>%FLA</b>
<b>P7</b>	<b>QST 07</b>	<b>Maximum Motor Current 1</b>	<b>600</b>	<b>%FLA</b>
<b>P8</b>	<b>QST 08</b>	<b>Ramp Time 1</b>	<b>15</b>	<b>Seconds</b>
<b>P9</b>	<b>QST 09</b>	<b>Up To Speed Time</b>	<b>20</b>	<b>Seconds</b>
P10	CFN 01	Start Mode	curr	
P11	CFN 08	Initial Voltage/Torque/Power	25	%
P12	CFN 09	Maximum Torque/Power	105	%
P13	CFN 10	Kick Level 1	Off	%FLA
P14	CFN 11	Kick Time 1	1.0	Seconds
P15	CFN 14	Stop Mode	Cos	
P16	CFN 15	Decel Begin Level	40	%
P17	CFN 16	Decel End Level	20	%
P18	CFN 17	Decel Time	15	Seconds
P19	CFN 18	DC Brake Level	25	%
P20	CFN 19	DC Brake Time	5	Seconds
P21	CFN 20	DC Brake Delay	0.2	Seconds
P22	CFN 06	Initial Motor Current 2	100	%FLA
P23	CFN 07	Maximum Motor Current 2	600	%FLA
P24	CFN 05	Ramp Time 2	15	Seconds
P25	CFN 12	Kick Level 2	Off	%FLA
P26	CFN 13	Kick Time 2	1.0	Seconds
P27	CFN 21	Slow Speed	Off	%
P28	CFN 22	Slow Speed Current Level	100	%FLA
P29	CFN 23	Slow Speed Time Limit	10	Seconds
P30	CFN 24	Slow Speed Kick Level	Off	%FLA
P31	CFN 25	Slow Speed Kick Time	1.0	Seconds
P32	PFN 01	Over Current Trip Level	Off	%FLA
P33	PFN 02	Over Current Trip Time	0.1	Seconds
P34	PFN 03	Under Current Trip Level	Off	%FLA
P35	PFN 04	Under Current Trip Time	0.1	Seconds
P36	PFN 05	Current Imbalance Trip Level	15	%
P37	PFN 06	Residual Ground Fault Trip Level	Off	%FLA
P38	PFN 07	Over Voltage Trip Level	Off	%
P39	PFN 08	Under Voltage Trip Level	Off	%
P40	PFN 09	Over/Under Voltage Trip Time	0.1	Seconds
P41	PFN 10	Auto Reset Time	Off	Seconds

\*NOTE: See MX<sup>2</sup> User Manual for the complete parameter descriptions.  
 \*NOTE: Parameters in bold print are the most commonly used in initial start up.

**Operating Parameters (Continued)**

Parameter	Description	Default	Units	
LED	LCD			
P42	PFN 11	Auto Reset Count	Off	Off, 1 - 10
P43	PFN 12	Controlled Fault Stop Enable	On	
P44	PFN 13	Independent Starting/Running Overload	Off	
P45	PFN 14	Motor Starting Overload Class	10	
P46	PFN 16	Motor Overload Hot/Cold Ratio	60	%
P47	PFN 17	Motor Overload Cooling Time	30	Minutes
P48	I/O 01	DI 1 Configuration	Stop	
P49	I/O 02	DI 2 Configuration	Off	
P50	I/O 03	DI 3 Configuration	Off	
P51	I/O 04	Digital Fault Input Trip Time	0.1	Seconds
P52	I/O 05	R1 Configuration	FLFS	
P53	I/O 06	R2 Configuration	Off	
P54	I/O 07	R3 Configuration	Off	
P55	I/O 08	Analog Input Trip Type	Off	
P56	I/O 09	Analog Input Trip Level	50	%
P57	I/O 10	Analog Input Trip Time	0.1	Seconds
P58	I/O 11	Analog Input Span	100	%
P59	I/O 12	Analog Input Offset	0	%
P60	I/O 13	Analog Output Function	0: Off	
P61	I/O 14	Analog Output Span	100	%
P62	I/O 15	Analog Output Offset	0	%
P63	I/O 16	Inline Configuration	3.0	Seconds
P64	I/O 17	Bypass Feedback Time	2.0	Seconds
P65	I/O 18	Keypad Stop Disable	Enabled	
P66	I/O 19	Power On Start Selection	0	
P67	FUN 15	Miscellaneous Commands	0	
P68	FUN 12	Communication Timeout	Off	Seconds
P69	FUN 11	Communication Baud Rate	19200	bps
P70	FUN 10	Communication Address	1	
P71	FUN 13	Communication Byte Framing	0	
P72	FUN 09	Energy Saver	Off	
P73	FUN 08	Heater Level	Off	%FLA
P74	FUN 07	Starter Type	nor	
P75	FUN 06	Rated Power Factor	-0.92	
<b>P76</b>	<b>FUN 05</b>	<b>Rated Voltage</b>	<b>480</b>	<b>RMS Volt.</b>
P77	FUN 04	Phase Order	InS	
<b>P78</b>	<b>FUN 03</b>	<b>CT Ratio</b>	<b>288:1</b>	
P79	FUN 01	Meter 1	Ave Current	
n/a	FUN 02	Meter 2	Ave Volts	
P80	FUN 14	Software 1 Part Number	810023-01-08	
P81	FUN 16	Passcode	Off	
P82	FL1-9	Fault Log		

\*NOTE: See MX<sup>2</sup> Instruction Manual for the complete parameter descriptions.  
 \*NOTE: Parameters in bold print are the most commonly used in initial start up.



**MX<sup>2</sup> Control**  
**Quickstart Reference Guide**  
 For The Integral LED and LCD Displays

For more information consult the  
 RediStart MX<sup>2</sup> User Manual  
 (RB2,RC2 & RX2E Models)

August 2008  
 Software Version: 810023-01-08  
 Hardware Version: 300055-01-05

USA Headquarters: (412) 487-8235  
 USA West: (480) 905-0601  
 Canada: (519) 291-5112  
 Website: <http://www.benshaw.com>  
 Email: [support@benshaw.com](mailto:support@benshaw.com)



### Reset Pushbutton

- To reset a fault condition.
- To perform an emergency thermal reset, press Reset and the Down pushbutton.

### Parameter Pushbutton

- Enter the parameter list.
- Exit the parameter list.
- Abort changing parameter.

### Down Pushbutton

- Select previous parameter.
- Decrease a parameter value.
- Quick Meter,** Toggle display of motor thermal overload content

### Up Pushbutton

- Select next parameter.
- Increase a parameter value.
- Quick Meter,** Toggle Display of incoming line phase order.

### Enter Pushbutton

- Select parameter.
- View a parameter.
- Store the new parameter value.
- Quick Meter,** Toggle Display of Status Meter (rdY, run, utS, dcL, etc.)

### LED Display

- View parameters, operating messages, and faults.
- Shows software revision when first powered on.

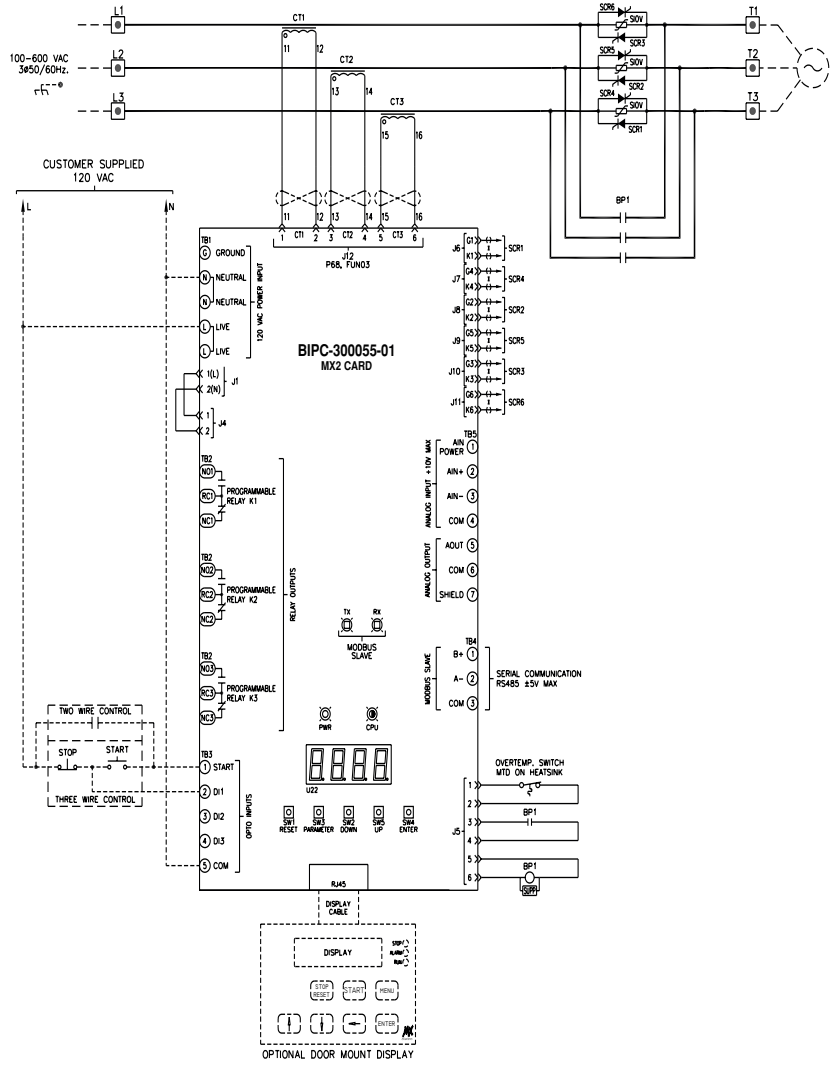
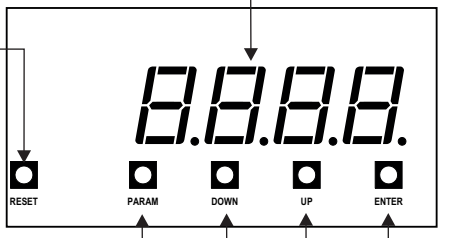

### Digital Input "DI 1 - 3" Configuration

P48 I/O 01	DI 1 Configuration	OFF: Off StOP: Stop FH: Fault High FL: Fault Low Fr: Fault Reset dSc: Disconnect InLn: Inline Cnfrm bUp: Bypass Cnfrm EoLr: E OL Reset	OFF: Off StOP: Stop FH: Fault High FL: Fault Low Fr: Fault Reset dSc: Disconnect InLn: Inline Cnfrm bUp: Bypass Cnfrm EoLr: E OL Reset	L-r: Local/Remote hdS: Heat Disable hEn: Heat Enable rSEL: Ramp Select SS F: Slow Spd Fwd SS R: Slow Spd Rev BdS: Brake Disabl BEn: Brake Enable runE: Run Enable rund: Run Disable
P49 I/O 02	DI 2 Configuration			
P50 I/O 03	DI 3 Configuration			

### Relay Output "R1 - 3" Configuration

P52 I/O 05	R1 Configuration SPDT form C 5 Amp, 125VAC, resistive 3 Amp, 250VAC, resistive 1250VA res, 500VA ind	OFF: Off FLFs: Fault FS FLrF: Fault NFS run: Running utS: UTS AL: Alarm rdYr: Ready LOC: Locked Out OC: Overcurrent UC: Undercurrent OLr: OL Alarm	Off Fault FS Fault NFS Running UTS Alarm Ready Locked Out Overcurrent Undercurrent OL Alarm	SHFS: Shunt FS shrF: Shunt NSF BFLt: Ground Fault ES: Energy Saver HErT: Heating SSPd: Slow Spd SSr: Slow Spd Fwd deb: Braking FAr: Cool Fan Ctl
P53 I/O 06	R2 Configuration -Same as R1			
P54 I/O 07	R3 Configuration SPDT form C 16 Amp, 240VAC resistive 16 Amp, 30VDC, resistive 1HP, 240VAC Make/Break VA-4000/400			

### Model Number

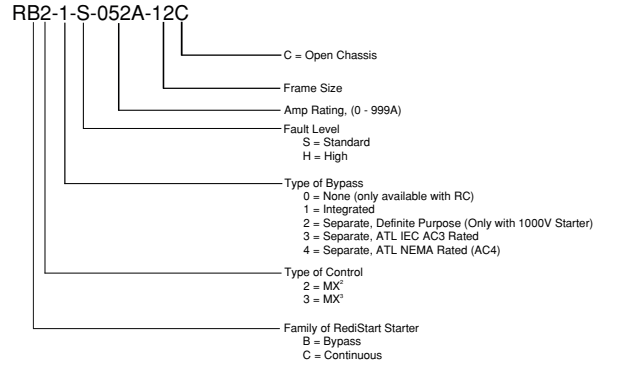

### Changing Parameter Values

- Parameter change mode can be entered by:
  - At the default meter display, press the [PARAM] key to enter parameter mode.
  - Use the [UP] and [DOWN] keys to scroll through the available parameters.
  - The value of the parameter can be viewed by pressing the [ENTER] key.
  - When viewing the parameter value, the parameter can be changed by using the [UP] and [DOWN] keys.
  - To store the new value, press the [ENTER] key. When the [ENTER] key is pressed the value is saved and the display goes back to parameter # "P\_".
- To exit parameter change mode without saving the new parameter value either:
  - Press the [PARAM] key to return to the parameter number display.
  - Wait 60 seconds and the display returns to the default meter display.

### Emergency Overload Reset

To perform an emergency overload reset, press [RESET] and [DOWN]. This sets the motor thermal overload content to 0.

### Resetting a Fault

To reset from a fault condition, press [RESET].

### Restoring Factory Parameter Settings

LED Display: To restore ALL parameters to the factory default settings, press and hold the [PARAM] and [ENTER] pushbutton switches on power up. The display blinks "dFLt".

LCD Display: To restore ALL parameters to the factory default settings, go to Miscellaneous commands FUN15 and press [ENTER]. Press [UP] until you read "Factory Rst" and press [ENTER].

⚠ NOTE: Parameters unique to the motor starter applications need to be set again to appropriate values before motor operation.

### Operating Messages (see user manual for any additional Operating Messages)

noL	No Line	FbC	Phase order meter showing ABC
rdY	Ready	CbA	Phase order meter showing CBA
Acc	Accelerating or Kicking	SPH	Phase order meter showing Single Phase
Acc2	Accelerating or Kicking with ramp 2	oxxx	xxx = overload content
utS	Up to Speed	P xx	xx = Parameter code
run	Run - Done with Accel ramp but not yet Up to Speed	A xx	xx = Alarm code. If the condition persists, a fault occurs
dcL	Decelerating Motor	F xx	xx = Fault code
AL OL	Overload Alarm - The motor overload level is between 90% and 100%	loc	Instantaneous Over current
F OL	Overload Fault - The motor overload level has reached 100%	dFLt	Default - Flashes when parameter defaults are loaded
		HErT	Heater/Anti-windmill Mode
		ES	Energy Saver
L OL	Overload Lockout - A start is not allowed until the motor overload level cools below 15%	FLSH	In reflash mode
L CP	Control Power Lockout - A start is not allowed because the control power is too low	PrCoS	In reflash mode, programming
		rEPd	In reflash mode, verifying
LOC	Lock out State	donE	In reflash mode, complete
SSPd	Slow Speed Motor Operation	L dS	Disconnect Switch Open
L Ot	Power Stack Over Temperature Lockout	deb	DC Injection Brake Active
SS r	Slow Speed Reverse	SS F	Slow Speed Forward
L I r	Digital Inputs (Run Enable or Run Disable) are preventing a run		