

BENSHAW
ADVANCED CONTROLS & DRIVES

REDISTART MICRO II
INSTRUCTION MANUAL
RSM6/6B/7/7B SERIES

The Leader In
Solid State Motor Control
Technology

TABLE OF CONTENTS

Table of Contents

1. INTRODUCTION	1
1.1 INTRODUCTION	2
Using This manual	2
Benshaw Services	3
Features	5
2. TECHNICAL SPECIFICATIONS	7
2.1 TECHNICAL SPECIFICATIONS.	8
CT (Current Transformer) Inputs.	8
Voltage Inputs.	8
Metering	8
Real Time Clock.	8
Output Relays.	8
Control Power.	9
Storage and Operating Conditions	9
DeviceNet (Embedded)	9
Modbus (Optional)	9
EU Declaration of Conformity	10
Overload Curves	11
Overload Curve Chart	12
Low Voltage UL/CUL Fault Ratings.	13
Low Voltage UL/CUL Fault Ratings.	14
RediStart Micro II CPU Jumpers	15
Computer Card JC11 Header Assignments	15
RediStart Micro II Power Card Jumpers	15
3. INSTALLATION.	17
3.1 INSTALLATION.	18
Site Preparation	18
EMC Installation guidelines.	18
Installation Procedures.	19
Preventative Maintenance	23
Ventilation Requirements	23
Remote RTD Module.	23
CT Mounting	24
CT Ratio Scaling	24
RediStart Micro II Computer Card Jumpers.	25

TABLE OF CONTENTS

4. OPERATION	27
4.1 OPERATION	28
Main Display Messages	28
Meter Display Pages	29
Parameters.	33
Starter Modes	33
Current Ramp Adjustment	34
Programming A Kick Current.	35
Jog at Set Speed	35
Tachometer Feedback	36
Programming The Motor Deceleration.	37
PORT (Power Outage Ride Through)	38
TruTorque Acceleration Ramp	38
TruTorque Deceleration Ramp	39
How Fault Classes Work.	40
Use of Overcurrent and Undercurrent	41
Overload.	41
Performing an Emergency Restart	43
5. PROGRAMMING	45
5.1 PROGRAMMING: How To Program	46
Menu Buttons	46
Menu Structure	47
Viewing a Parameter	48
Changing a Parameter	48
5.2 PROGRAMMING: Quick Start	49
Motor FLA.	49
Serv. Fact (service factor)	49
Start Mode.	49
Stop Mode.	49
Int. Curr. (initial current)	50
Max. Curr. (maximum current)	50
Ramp Time	50
Overload.	51
Phase Orde (Phase Order)	51
5.3 PROGRAMMING: Motor Nameplate	52
Motor FLA.	52
Serv. Fact (service factor)	52
Motor RPMs.	52
Energy Sav (energy saver).	52
Source Volt (source voltage).	53
5.4 PROGRAMMING: Starter Setup - Starter Modes	54
Start Mode.	54
Stop Mode.	54
5.5 PROGRAMMING: Starter Setup - Forward1 Profile	55
Int. Curr. (initial current)	55
Max. Curr. (maximum current)	55
Ramp Time	55
Kick Curr. (kick current).	56
Kick Time	56

TABLE OF CONTENTS

5.6 PROGRAMMING: Starter Setup - Forward2 Profile	57
Forward #2 Ramp Profile	57
Int. Curr. (initial current)	57
Max. Curr. (maximum current)	57
Ramp Time	57
Kick Curr. (kick current)	58
Kick Time	58
5.7 PROGRAMMING: Starter Setup - Jog Cntrl Setup	59
Jog Curr. (jog current)	59
Max. Time (maximum time)	59
Kick Curr (kick current)	60
Kick Time	60
FWD Speed	60
5.8 PROGRAMMING: Starter Setup - Tachometer Setup	61
FS Volts (Full Speed Volts)	61
Stab Cnst (Stability Constant)	61
Ramp#1 Tim.	61
Ramp#2 Tim.	61
TLoss Dela (Tachometer Signal Loss Delay)	62
TLoss Mode (Tachometer Signal Loss Mode)	62
5.9 PROGRAMMING: Starter Setup - Brake Ctl Setup	63
D.C. Injection Braking	63
Current #1	63
Time #1	63
Current #2	63
Time #2	64
5.10 PROGRAMMING: Starter Setup - Decel Setup	65
V Level #1	65
V Level #2	65
V DCL Time (decel time)	65
TT DCL Tim (TruTorque deceleration time)	66
TT DCL Tor (ending deceleration torque)	66
5.11 PROGRAMMING: Starter Setup - PORT CTL Setup	67
Fault Dly (Fault Delay)	67
Bypass Dly (Bypass Delay)	67
Sense Time	67
5.12 PROGRAMMING: Starter Setup - TruTorque Ramp	68
Int Torque (initial torque)	68
Max Torque (maximum torque)	68
Ramp Time	68
TT Over Cu (TruTorque overcurrent trip)	69
Ovr Cur Dl (TruTorque overcurrent trip delay)	69
5.13 PROGRAMMING: Starter Setup - Heat/ Anti-wind	70
Heat Curr. (heater current)	70
5.14 PROGRAMMING: Motor Protection - Overload	71
Overload	71

TABLE OF CONTENTS

5.15 PROGRAMMING: Motor Protection - Line Current	72
% Imbalanc (percent imbalance)	72
Imbal Dela (imbalance delay)	72
@ Stop Dly (current at stop delay)	72
% No C@Run (percent no current at run)	73
No C@R Dly (no current at run delay)	73
5.16 PROGRAMMING: Motor Protection - Line Voltage	74
H/L Volts (high/low voltage)	74
Delay Time	74
PH Dect DI (Phase detect delay)	74
5.17 PROGRAMMING: Motor Protection - Line Frequency.	75
High Freq. (high frequency).	75
Low Freq. (low frequency).	75
Freq Delay (frequency delay)	75
5.18 PROGRAMMING: Motor Protection - Ground Fault.	76
GND Fault (ground fault)	76
GND Delay (ground delay)	76
5.19 PROGRAMMING: Motor Protection - Shorted SCR	77
@ Ramp DLY (shorted SCR at ramp delay)	77
@ Stop DLY (shorted SCR at stop delay).	77
5.20 PROGRAMMING: Motor Protection - Over Current.	78
Current.	78
Detect Dly (detect delay).	78
Release DI (release delay)	78
5.21 PROGRAMMING: Motor Protection - Under Current	79
Current.	79
Detect Dly (detect delay).	79
Release DI (release delay)	79
5.22 PROGRAMMING: Motor Protection - Start Lockouts	80
Starts/Hou (starts per hour).	80
Time Start (time between starts)	80
BKS Timer (backspin timer)	80
5.23 PROGRAMMING: Motor Protection - Starting Timers.	81
UTS Timer (up-to-speed timer)	81
Zero Speed.	81
5.24 PROGRAMMING: Motor Protection - Permissive Input.	82
Therm. In	82
5.25 PROGRAMMING: Motor Protection - Misc..	83
Phase Orde (phase order)	83
# Auto RST (number of auto resets)	83
No Main PW (no main power)	83
5.26 PROGRAMMING: Motor Protection - Fault Classes	84
Fault Classes.	84
5.27 PROGRAMMING: Meters & Relays - Meter Setup	85
Meter #1 , Meter #2.	85
AutoRange.	86
Meter Rsts (meter resets).	86
Scroll Tim (scroll time)	86

TABLE OF CONTENTS

5.28 PROGRAMMING: Meters & Relays - Standard Relays	87
Relay#1, K5 and Relay#2, K6	87
5.29 PROGRAMMING: Meters & Relays - Extended Relays	88
Opt. #?, K?.	88
5.30 PROGRAMMING: Event Recorder	89
Event Recorder	89
5.31 PROGRAMMING: Control Config - System Clock	91
System Clock	91
5.32 PROGRAMMING: Control Config - System Password	92
Password	92
5.33 PROGRAMMING: Control Config - Comm. Settings	93
COMM. Mode (communications mode)	93
COM Address (communications address)	93
COM Delay (communications delay).	93
MB:Baud (MODBUS baud rate).	94
MB:Com T/O (MODBUS communications timeout).	94
DN:MAC ID (DeviceNet MAC ID)	94
DN:Baud (DeviceNet baud rate)	94
DN:InAssy (DeviceNet input assembly)	95
DN:OutAssy (DeviceNet output assembly)	95
DN:T/O Act (DeviceNet timeout action)	95
DN:Rev (DeviceNet interface revision)	95
5.34 PROGRAMMING: Control Config - Options List.	96
Options List	96
5.35 PROGRAMMING: Control Config - Software Part#	97
Software Part#	97
5.36 PROGRAMMING: Factory Setup - Hardware Setup	98
C.T. Ratio	98
Relay Card.	98
5.37 PROGRAMMING: Factory Setup - Factory Control	99
FACT Pass. (factory password)	99
Reset Def (reset to default parameters).	99
CLR Events (clear event log)	99
CLR Pass. (clear password)	99
Cal Volt L1, L2, L3 (calibrate voltage meter).	99
Cal Curr L1, L2, L3 (calibrate current meter)	100
5.38 PROGRAMMING: RTD Setup - RTD Module Setup	101
Mod#1 Addr (module #1 address)	101
Mod#2 Addr (module #2 address)	101
#RTDs Mod1 (number of RTDs on module #1).	101
#RTDs Mod2 (number of RTDs on module #2).	101
Temp Scale (temperature scale)	101
5.39 PROGRAMMING: RTD Setup - RTD SetPnts 1-8	102
RTD#? Grp (RTD #? Group).	102
RTD#? Warn (RTD #? warning level)	102
RTD#? Alm (RTD #? alarm level).	102

TABLE OF CONTENTS

5.40 PROGRAMMING: RTD Setup - RTD SetPnts 9-16	103
RTD#? Grp (RTD #? Group).	103
RTD#? Warn (RTD #? warning level)	103
RTD#? Alm (RTD #? alarm level).	103
6. TROUBLESHOOTING	105
6.1 TROUBLESHOOTING	106
LED Diagnostics	106
Meter Tests	107
Event Recorder	107
Fault/Log Codes	108
General Troubleshooting Charts	112
Spare Parts.	114
SCR Replacement.	115
7. DRAWINGS	117
7.1 DRAWINGS	118
RediStart Micro II Computer Card Diagram	118
RediStart Micro II Power Card Layout.	119
Old RediStart Micro Power Card Layout	120
RediStart Micro II Four (4) Relay Card Layout	121
RediStart Micro II Seven (7) Relay Card Layout	121
RediStart Micro II RS-232 Communications Card Layout	122
RediStart Micro II RS-485 Communications Card Layout	122
RediStart Micro II RS-232/485 Communications Card Layout	123
RediStart Micro II Reversing/Braking Card Layout	123
Modbus Master Card (for Remote RTD Module)	124
RediStart Micro II Display Cut-out	125
8. PARAMETER LIST	127
8.1 Parameter List	128
RediStart Micro II Parameter List.	128
Quick Start.	128
Motor Nameplate.	128
Starter Setup.	128
Motor Protection	130
Meters & Relays.	132
Event Recorder	133
Control Config	133
Factory Setup	134
RTD Setup.	134

1.

INTRODUCTION

1.1 INTRODUCTION

Using This manual

Layout

This manual is divided into eight sections. Each section contains topics related to the section. The sections are as follows;

- **Introduction** - Basic RediStart Micro II information.
- **Technical Specifications** - RediStart Micro II specifications.
- **Installation** - Information on installing the RediStart Micro II.
- **Operation** - Information on how the starter operates.
- **Programming** - Programming the RediStart Micro II.
- **Troubleshooting** - Diagnosing RediStart Micro II problems.
- **Drawings** - RediStart Micro II layout drawings.
- **Parameter List** - List allowing user to record programmed values.

Parameter List

The last chapter of the manual is a parameter list. This list gives the user a place to enter the programmed value for each parameter and also gives the page number where the description of the parameter can be found. This list can be used as a quick reference to find the information on a parameter.

Symbols

There are two symbols used in this manual to highlight important information. The symbols appear as the following;



Electrical hazard that could result in injury or death.



Caution that could result in damage to the starter or motor.
Highlight marking an important point in the documentation.

Benshaw Services

General Information

Benshaw offers its customers the following services:

- Start-up services.
- On-site training services.
- Technical support.
- Detailed documentation.
- Replacement parts.

NOTE: Information about products and services is available by contacting Benshaw.

Start-Up Services

Benshaw technical field support personnel are available to assist customers with the initial start-up of the RediStart Micro II. Information about start-up services and fees are available by contacting Benshaw.

On-Site Training Services

Benshaw technical field support personnel are available to conduct on-site training on RediStart Micro II operations and troubleshooting.

Technical Support

Benshaw technical support personnel are available (at no charge) to answer customer questions and provide technical support over the telephone. For information about contacting technical support personnel, refer to Contacting Benshaw on page 4.

Documentation

Benshaw provides all customers with:

- Operations manual.
- Wiring diagram.

All drawings are produced in AutoCAD© format. The drawings are available on standard 3.5" diskettes or via e-mail by contacting Benshaw.

On-Line Documentation

All RediStart MicroII documentation is available on-line at www.benshaw.com.

Replacement Parts

Spare and replacement parts can be purchased from Benshaw.

1.1 INTRODUCTION

Contacting Benshaw

Information about Benshaw products and services is available by contacting Benshaw at one of the following offices:

Benshaw Inc. Corporate Headquarters
1659 E. Sutter Road
Glenshaw, PA 15116
United States of America
Phone: (412) 487 8235
Fax: (412) 487 4201

Benshaw Canada Controls Inc.
R.R. #1 (Wallace Industrial Park)
Listowel, Ontario
Canada
N4W 3G6
Phone: (519) 291 5112
Fax: (519) 291 2595

Benshaw West
7820 E. Evans Drive, Suite 900
Scottsdale, AZ 85260
United States of America
Phone: (480) 905 0601
Fax: (480) 905 0757

Technical support for the RediStart Micro II is available at no charge by contacting Benshaw's customer service department at one of the above telephone numbers. A service technician is available Monday through Friday from 8:00 a.m. to 5:00 p.m. EST.

NOTE: An on-call technician is available after normal business hours and on weekends by calling Benshaw and following the recorded instructions.

To help assure prompt and accurate service, please have the following information available when contacting Benshaw:

- Name of company.
- Telephone number where caller can be contacted.
- Fax number of caller.
- Benshaw product name.
- Benshaw model number.
- Benshaw serial number.
- Name of product distributor.
- Approximate date of purchase.
- Voltage of motor attached to Benshaw product.
- FLA of motor attached to Benshaw product.
- A brief description of the application.

General

- Chassis or NEMA 1, 4, 12, or 3R enclosure

Protection (ANSI standard numbers given)

- 51 - Electronic motor overload (Off, class 1 to 40, or bypass during start)
- 86 - Overload lockout
- 48 - Adjustable up-to-speed timer (off; 0 to 300 seconds)
- 59/27 - Adjustable over/under voltage protection
- 46 - Adjustable line to average current imbalance
- 81 - Adjustable high and low frequency protection
- Single phase protection
- 66 - Adjustable starts per hour (off or 1 to 20 starts)
- Adjustable time between starts (off or 1 to 600 minutes)
- Backspin timer (off or 1 to 200 minutes)
- 51 - Over current detection (Off or 50 to 800%) and time (0.1 to 90.0 sec. in 0.1 sec. intervals)
- 37 - Undercurrent detection (Off or 10 to 100% and time (0.1 to 90.0 sec. in 0.1 sec. intervals)
- 51G - Ground fault detection (Off or 1 to 100 amps) and time (0.1 to 90.0 sec. in 0.1 sec. intervals)
- Over-current, undercurrent, and ground fault can each be set to trip or activate a relay
- 50 - Instantaneous electronic over-current trip
- Shorted SCR detection
- 47 - Phase rotation selectable ABC, CBA, or Ins (insensitive)
- 38/49 - Remote Mountable RTD protection package, 8 or 16 RTD inputs (optional)
- PORT (power outage ride through) available with external 120VAC.

Control

- Two programmable current ramp profiles selectable at any time via 120 volt input
- Initial current, maximum current, and ramp time adjustments for each ramp
- Kick Current and time adjustments for each ramp
- TruTorque acceleration and deceleration profiles
- Adjustable deceleration profiles (to eliminate water hammer)
- Adjustable brake profile
- Energy saver (on or off)
- Local start/stop controls
- Emergency reset capability
- Tachometer ramp control (requires 0-5VDC tachometer feedback signal)

Input/Output and Display

- Plain English operation via back lit LCD display interface
- LCD and LED status and diagnostics (full fault annunciation)
- Programmable metering (amps, volts, frequency, overload, power factor, elapsed time, watts, VARs, watt-hours, VA, Current Imbalance, Ground Fault Current, RTD temperatures)
- Programmable relay outputs
- Latched fault relay output
- Real time clock
- Time stamped event recorder
- Password protection
- Battery backed-up starter parameters and lockout times

2. TECHNICAL SPECIFICATIONS

2.1 TECHNICAL SPECIFICATIONS

CT (Current Transformer) Inputs

Conversion	Calibrated RMS, 12 samples per cycle
Range	0.01 to $1.5 \times$ phase CT primary amps set point
Accuracy	$\pm 3.5\%$ of phase CT primary amps set point
Frequency	23 to 72 Hz
Current Withstand	- $2.0 \times$ CT primary amps set point (CT ratio parameter) - continuous - $10 \times$ CT primary amps set point (CT ratio parameter) - 30 seconds - $55 \times$ CT primary amps set point (CT ratio parameter) - 1 seconds

Voltage Inputs

Conversion	Calibrated RMS, 12 samples per cycle
Range	1000VAC to 9999VAC
Accuracy	$\pm 3.5\%$ of full range

Metering

Current	$\pm 5\%$, 0 to 9999Amps
Voltage	$\pm 5\%$, 0 to 9999Volts
Watts	$\pm 5\%$, 0 to 6553kW
Volt-Amps Reactive	$\pm 5\%$, 0 to 6553kVAR
Volt-Amps	$\pm 5\%$, 0 to 6553kVA
WH	$\pm 5\%$, 0 to 6553MWH
PF	$\pm 3\%$, -0.01 to +0.01

Real Time Clock

Accuracy	± 1 minute per month
Range	1/1/1970 to 1/1/2069

Output Relays

Fault Relay	- SPDT - Form C - 2A, 125VAC, resistive - 1A, 125VAC, 0.4 PF - 2A, 30VDC resistive - 100VA inrush
Output Relay #1 & #2	- SPDT - Form C - 16A, 250VAC resistive - 8A, 250VAC 0.4 PF - 16A, 30VDC resistive - 2000VA inrush

2.1 TECHNICAL SPECIFICATIONS

Four Relay Card

- DPDT - Dual Form C
- 5A, 250VAC, resistive
- 2A, 250VAC, 0.4 PF
- 5A, 30VDC, resistive
- 500VA inrush

Seven Relay Card

- SPDT - Form C
- 8A, 250VAC resistive
- 4A, 250VAC 0.4 PF
- 8A, 30VDC resistive
- 800VA inrush

Control Power

Voltage 120VAC, ±15%
240VAC, ±15% (Optional)

Frequency 50 to 60hz

Power Consumption Varies for required control.

Fuse Time delay control circuit protection fuses.

Storage and Operating Conditions

Storage -20°C (-4°F) to +60°C (+140°F)
0% to 95% relative humidity, non-condensing

Operating 0°C (+32°F) to +50°C (+122°F)
0% to 95% relative humidity, non-condensing

DeviceNet (Embedded)

Manual Available at www.benshaw.com or from your Benshaw sales office.

EDS File Available at www.benshaw.com or from your Benshaw sales office.

Device Type Softstart Starter

I/O Slave Messaging Polling

Baud Rates

- 125K
- 250K
- 500K

Conformance Self tested with ODVA (open DeviceNet Vendor Association) software.

Modbus (Optional)

Manual Available at www.benshaw.com or from your Benshaw sales office.

Type Modbus RTU

Connections

- RS-232
- RS-485

Baud Rates

- 2400
- 4800
- 9600

2.1 TECHNICAL SPECIFICATIONS

EU Declaration of Conformity

According to the EMC – Directive 89/336/EEC as Amended by 92/31/EEC and 93/68/EEC

Product Category: Motor Controller
Product Type: Reduced Voltage Solid State Motor Controller
Model Numbers: RSM6, RSM7, RSM10, RSM11, RMB6, MVRSM12/18
Manufactures Name: Benshaw, Inc.
Manufacture's Address: 1659 East Sutter Road
Glenshaw, PA USA
15116

The before mentioned products comply with the following EU directives and Standards:

Safety: UL 508 Standard for Industrial Control Equipment covering devices for starting, stopping, regulating, controlling, or protecting electric motors with ratings of 1500 volts or less.

EMC: EN 50081-2 Emissions Radiated/Conducted
EN 55011/05.98+A1:1999

EN 50082-2 Immunity/Susceptibility which includes:
EN 61000-4-2 Electrostatic Discharge
EN 61000-4-3 Radiated RF
EN 61000-4-4 Electrical Fast Transient/Burst
EN 61000-4-6 Injected Currents

The technical files and other documentation are on file at Benshaw, Inc. and controlled by the Product Engineering Group. Benshaw, Inc. has internal production control systems that ensures compliance between the manufactured products and the technical documentation.

Neil Abrams
Quality Control Manager

Harry Hagerty
Advanced Controls and Drives Manager

Charles E. Cook
Product Development Manager

2.1 TECHNICAL SPECIFICATIONS

Overload Curves

General

The RediStart Micro II comes with forty (40) standard overload curves. The 100% (no trip) point is the motor FLA setting multiplied by the service factor. These curves are shown on the next page.

NOTE: The user can display the overload by setting the overload to Off. The overload can also be set to BYP (Bypass), which limits the charging current during ramping to 90%. Once the unit has reached UTS (up-to-speed), the overload can charge the remaining 10%. This is useful on extremely large centrifugal loads such as centrifuges.

NOTE: When the overload counter is at a number other than 0%, the time to trip will be lowered by this percentage.

NOTE: In heavy duty DC braking application, the overload settings may be limited to protect the starter and motor from potential damage.



Caution must be taken when using the Bypass mode. The starter does not overload protect the unit during the start.

Curves

The overload can be set to;

- OFF - no thermal overload
- 1-40 - class 1 through 40 overload in steps of 1.
- BYP - overload bypassed during starting, class 10 once up-to-speed

Trip Time Accuracy

±2 seconds up to 30 seconds

2.1 TECHNICAL SPECIFICATIONS

Overload Curve Chart

RediStart Micro II Overload Curves

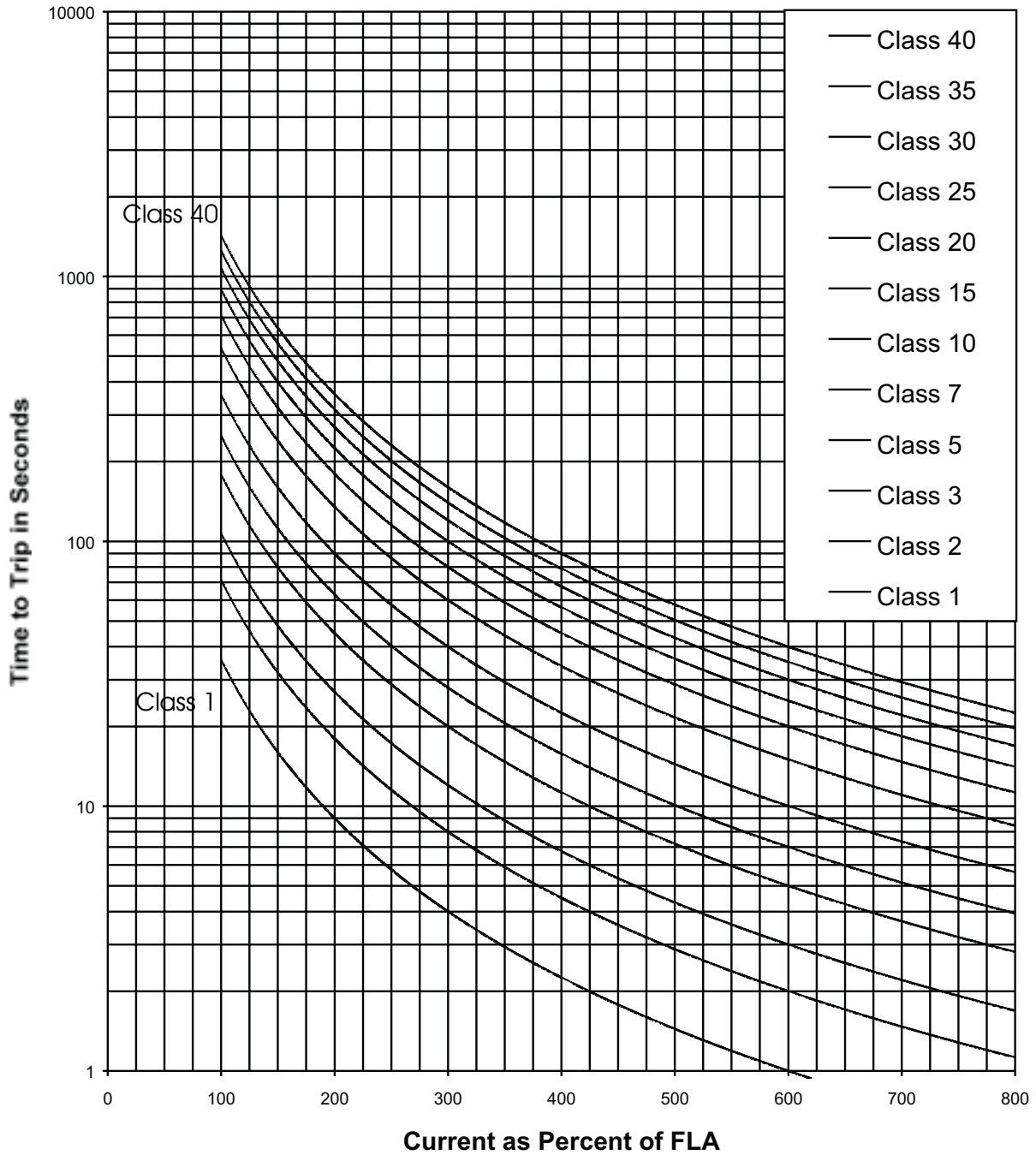

2.1 TECHNICAL SPECIFICATIONS

Low Voltage UL/CUL Fault Ratings

FLA (amps)	125% Current Rating (amps)	Unit Withstand Rating	Fuse Protected Rating			Current Limiting Circuit Breaker Protected Rating		
			Fuse Class	Max. Fuse Current Rating	Short Circuit Rating	Catalog Number	Trip Plug	Short Circuit Rating
1200	1440	85kA	L	1600A 2000A	100kA 50kA	HPD63F160	1200-1600A	85kA
960	1200	85kA	L	1600A 2000A	100kA 50kA	HPD63F160	1200-1600A	85kA
840	1050	85kA	L	1600A	100kA	CND63B CND63B	1200A 800A	85kA
720	900	42kA	L	1600A	100kA	CND63B CND63B	1200A 800A	85kA
590	737	42kA	L	1400A	100kA	CND63B CND63B	1200A 800A	85kA
477	596	42kA	J, 600VAC T, RK-1	800A	100kA	CLD63B CJD63B	600A 400A	65kA
361	421	42kA	J, 600VAC T, RK-1	800A	100kA	CLD63B CJD63B	600A 400A	65kA
302	377	42kA	J, 600VAC T, RK-1	800A	100kA	CFD63B	400A	65kA
240	300	42kA	J, 600VAC T, RK-1	600A	100kA	CFD63B	400A	65kA
180	225	42kA	J, 600VAC T, RK-1	400A	100kA	CFD63B	250A	65kA
156	195	42kA	J, 600VAC T, RK-1	400A	100kA	CFD63B	225A	65kA
124	155	42kA	J, 600VAC T, RK-1	350A	100kA	CFD63B	225A	42KA
96	120	42kA	J, 600VAC T, RK-1	225A	100kA	CFD63B	225A	42KA
77	96	42kA	J, 600VAC T, RK-1	225A	100kA	CED63B	125A	42KA
65	81	42kA	J, 600VAC T, RK-1	225A	100kA	CED63B	100A	42KA
52	65	42kA	RK-1	60A 100A	100kA 50KA	CED63B	100A	42KA
40	50	42kA	RK-1	60A 100A	100kA 50KA	CED63B	60A	42KA
27	33.75	42KA	J, 600VAC T, RK-1, G, CD	40A 60A	100KA 50KA	CED63B	60A	42KA

TABLE CONTINUED NEXT PAGE

2.1 TECHNICAL SPECIFICATIONS

Low Voltage UL/CUL Fault Ratings

TABLE CONTINUED PREVIOUS PAGE

FLA (amps)	125% Current Rating (amps)	Unit Withstand Rating	Fuse Protected Rating		Fuse Protected Rating		Current Limiting Circuit Breaker Protected Rating		
			Fuse Class	Max. Fuse Current Rating	Short Circuit Rating	Catalog Number	Trip Plug	Short Circuit Rating	
21	26.25	42	J, 600VAC T, RK-1	35A	100KA	CED63B	80A	65KA	
				45A	50KA				
14	17.5	42	J, 600VAC T, RK-1	20A	100KA	CED63B	50A	65KA	
				30A	50KA				
11	13.75	42	J, 600VAC T, RK-1	15A	100KA	CED63B	40A	65KA	
				20A	50KA				
7.6	9.5	42	J, 600VAC T, RK-1	12A	100KA	CED63B	30A	65KA	
				15A	50KA				
4.8	6	42	J, 600VAC T, RK-1	8A	100KA	CED63B	20A	65KA	
				10A	50KA				
3.4	4.25	42	J, 600VAC T, RK-1	5A	100KA	CED63B	15A	65KA	
				7A	50KA				

2.1 TECHNICAL SPECIFICATIONS

RediStart Micro II CPU Jumpers

Jumper	Description	Position 1-2 (In - 2-pos. jumper)	Position 2-3 (Out - 2-pos. jumper)	Standard
JPC5	LCD Start Button	Enable	Disable	1-2
JPC7	O/L Reset Auto/Manual	Automatic	Manual	2-3
JPC8	Display Format	Standard	Local Bus	1-2
JPC12	SCR Firing	Pulse	Block	In
JPC13	LCD Stop Button	Enable	Disable	1-2
JPC14	RAM Size	8K RAM	2K RAM	1-2
JPC15	PWM/ADDR16	ADDR16	PWM	1-2,3-4
JPC16	RS-232 Communications	Enable	Disable	Out
JPC17	Equip Forward Bypass	Yes	No	2-3
JPC18	Equip Reverse Bypass	Yes	No	2-3
JPC19	Fault Reset	Automatic	Manual	2-3
JPC25	Synchronous Application	Yes	No	Out
JPC27	Micro Enable/ADDR17	ADDR17	Enable	1-2,3-4

Computer Card JC11 Header Assignments

Position	Assignment
1-16	Not used.
2-15	Enables D.C. Braking.
3-14	Starter Equipped with MODBUS master card (for RTD module).
4-13	Enables Motor Winding Heater/Anti-windmilling Brake.
5-12	Not used.
6-11	Enables emergency reset.
7-10	Enables light duty braking (2-15 must also be installed for this option).
8-9	Not used.

RediStart Micro II Power Card Jumpers

Jumper	Description	Position 1-2	Position 2-3	Standard
JPP2	Line Synching	Line to Line	Line to Neutral	1-2
JPP3	Line Synching	Line to Line	Line to Neutral	1-2
JPP4	Line Synching	Line to Line	Line to Neutral	1-2

NOTE: Jumpers JPP2, JPP3, and JPP4 do not apply to the BIPC-300030-xx Power Card.

2.1 TECHNICAL SPECIFICATIONS

3.

INSTALLATION

3.1 INSTALLATION

Site Preparation

General	<p>Before the installation of the RediStart Micro II, the site should be prepared. The customer is responsible for:</p> <ul style="list-style-type: none">• Providing the correct power source.• Selecting the control mechanism.• Providing the connection cables and associated hardware.• Ensuring the installation site meets all environmental specifications for the enclosure NEMA rating.
Connection Cables	<p>The connection cables for the starter must have the correct NEC/C.S.A. current rating for the unit being installed. Depending upon the model, the connection cables can range from a single #14 AWG conductor to four 750 MCM cables.</p>
Site Requirements	<p>The installation site must adhere to the applicable starter NEMA rating. For optimal performance, the installation site must meet the following specifications, unless equipment (such as a heater or air conditioner) was added to the unit for operation outside of these ranges:</p> <ul style="list-style-type: none">• Temperature: 0°C (+32F) to 40°C (+104°F).• Humidity: 20% to 95% non-condensing.• Airways: Clearances are provided around all heat sinks.• Altitude: Less than 3300 feet (1000 meters) above sea level. <p>NOTE: The starter rating must be derated 1% for every 330 feet (100 meters) above 3300 feet (1000 meters).</p>
Mounting	<p>The starter must be mounted so the heat sink fins are vertically oriented in an area that does not experience excessive shock or vibration. All models require airway passages around the heat sink. During normal operation the heat sink may reach 194 degrees Fahrenheit (90 degrees Centigrade). Do not install the starter in direct contact with any materials that cannot withstand these temperatures.</p>

EMC Installation guidelines

General	<p>In order to help our customers comply with European electromagnetic compatibility standards, Benschaw Inc. has developed the following guidelines.</p> <p>Attention: This product has been designed for Class A equipment. Use of the product in domestic environments may cause radio interference, in which case the installer may need to use additional mitigation methods.</p>
Enclosure	<p>Install the product in a grounded metal enclosure.</p>
Grounding	<p>Connect a grounding conductor to the screw or terminal provided as standard on each controller. Refer to layout/power wiring schematic for grounding provision location.</p>
Wiring	<p>Wire in an industrial application can be divided into three groups: power control and signal. The following recommendations for physical separation between these groups are provided to reduce the coupling effect;</p> <ul style="list-style-type: none">• Different wire groups should cross at 90 degrees inside an enclosure.• Minimum spacing between different wiring groups in the same tray should be six inches.• Wire runs outside an enclosure should be run in conduit or have shielding/armor with equivalent attenuation.• Different wire groups should be run in separate conduits.• Minimum spacing between conduits containing different wire groups should be three inches (8cm).
Filtering	<p>To comply with Conducted Voltage Limits a 0.33 uF capacitor should be connected between each incoming power line and ground at a point nearest to where the incoming power enters the enclosure.</p>

Installation Procedures

General Information

Installation of some models may require halting production during installation. If applicable, ensure that the starter is installed when production can be halted long enough to accommodate the installation.

Before installing the starter, ensure:

- The wiring diagram (supplied separately with the starter) is correct for the required application.
- The starter is the correct current rating for the motor being started.
- All of the installation safety precautions are followed.
- The correct power source is available.
- The starter control method has been selected.
- The necessary installation tools and supplies are obtained.
- The installation site meets all environmental specifications for the starter NEMA/CEMA rating.
- The motor being started has been installed and is ready to be started.
- Any power factor correction capacitors (PFCC) are installed on the power source side of the starter and not on the motor side.

NOTE: Failure to remove power factor correction or surge capacitors from the load side of the starter will result in serious damage to the starter which will not be covered by the starter's warranty. The capacitors must be powered from the line side of the starter. The up-to-speed contact can be used to energize the capacitors after the motor has reached full speed.

Safety Precautions

To ensure the safety of the individuals installing the starter, and the safe operation of the starter, observe the following guidelines:

- Ensure that the installation site meets all of the required environmental conditions (Refer to Site Preparation, page 18).
- **LOCK OUT ALL SOURCES OF POWER.**
- Install circuit disconnecting devices (i.e., circuit breaker, fused disconnect or non-fused disconnect) if they were not previously installed by the factory as part of the package.
- Install short circuit protection (i.e., circuit breaker or fuses) if not previously installed by the factory as part of the package. See page 14 for the fault rating table.
- Follow all NEC (National Electrical Code) and/or C.S.A. (Canadian Standards Association) standards.
- Remove any foreign objects from the interior of the enclosure.
- Ensure that wiring is installed by an experienced electrician.
- Ensure that the individuals installing the starter have protective eye wear and clothing.

The opening of the branch circuit protective device may be an indication that a fault current has been interrupted. To reduce the risk of electrical shock, current carrying parts and other components of the starter should be inspected and replaced if damaged.

3.1 INSTALLATION

Installation

To begin installation:

- Read and follow all of the installation safety precautions.
- Procure the necessary installation tools and any supplies.
- Ensure the site has sufficient lighting for safe installation.
- Move the starter to the installation site.
- Ensure that the starter is positioned so that the cabinet door has ample clearance, and all of the controls are accessible.
- DO NOT install the starter in direct contact with any materials that cannot withstand the maximum heat sink temperature of 194 degrees Fahrenheit (90 degrees Centigrade). All models require airway passages around the heat sink for proper cooling.

If the starter is to be wall mounted:

- Mount the starter on the applicable surface using the appropriate hardware.

NOTE: Moving some models may require more than one individual or lifting equipment (e.g., forklift, crane).

Control Wiring

The control wiring should be connected to suit the customers needs. The control terminals on the control cards are as follows:

RediStart Micro II Power Card (refer to card layout on page 119):

- TBP1-1 24VDC common for relay and reversing card
- TBP1-2 24VDC power for relay and reversing card

- TBP2-1 Run relay neutral
- TBP2-2 Run relay live
- TBP2-5 Run relay holding contact

- TBP3-1 General fault contact N.C. (not faulted)
- TBP3-2 General fault contact common
- TBP3-3 General fault contact N.O. (not faulted)
- TBP3-4 Programmable relay #1 N.O.
- TBP3-5 Programmable relay #1 common
- TBP3-6 Programmable relay #1 N.C.
- TBP3-7 Programmable relay #2 N.O.
- TBP3-8 Programmable relay #2 common
- TBP3-9 Programmable relay #2 N.C.

RediStart Micro II computer card inputs (refer to card layout on page 118):

- JC13-1 Heat sink thermal switch or external starter trip input.
- JC13-2 AC neutral.
- JC13-3 Run confirm.
- JC13-4 Jog operation select.
- JC13-5 Not Used.
- JC13-6 Reverse operation select (for Jog and Reversing).
- JC13-7 Brake disable.
- JC13-8 Zero Speed input or motor winding heater/anti-windmilling brake select.
- JC13-9 Ramp #2 operation select.
- JC13-10 External motor thermal overload reset.
- JC13-11 External computer reset.
- JC13-12 AC neutral.

RediStart Micro II Four (4) Relay Card (refer to card layout on page 121):

- TB2-1 Optional programmable relay #1 N.O.
- TB2-2 Optional programmable relay #1 N.C.
- TB2-3 Optional programmable relay #1 common
- TB2-4 Optional programmable relay #1 N.O.
- TB2-5 Optional programmable relay #1 N.C.
- TB2-6 Optional programmable relay #1 common
- TB2-7 Optional programmable relay #2 N.O.
- TB2-8 Optional programmable relay #2 N.C.
- TB2-9 Optional programmable relay #2 common
- TB2-10 Optional programmable relay #2 N.O.
- TB2-11 Optional programmable relay #2 N.C.
- TB2-12 Optional programmable relay #2 common
- TB2-13 Optional programmable relay #3 N.O.
- TB2-14 Optional programmable relay #3 N.C.
- TB2-15 Optional programmable relay #3 common
- TB2-16 Optional programmable relay #3 N.O.
- TB2-17 Optional programmable relay #3 N.C.
- TB2-18 Optional programmable relay #3 common
- TB2-19 Optional programmable relay #4 N.O.
- TB2-20 Optional programmable relay #4 N.C.
- TB2-21 Optional programmable relay #4 common
- TB2-22 Optional programmable relay #4 N.O.
- TB2-23 Optional programmable relay #4 N.C.
- TB2-24 Optional programmable relay #4 common

RediStart Micro II seven (7) Relay Card (refer to card layout on page 121):

- TB2-1 Optional programmable relay #1 N.O.
- TB2-2 Optional programmable relay #1 common
- TB2-3 Optional programmable relay #1 N.C.
- TB2-4 Optional programmable relay #2 N.O.
- TB2-5 Optional programmable relay #2 common
- TB2-6 Optional programmable relay #2 N.C.
- TB2-7 Optional programmable relay #3 N.O.
- TB2-8 Optional programmable relay #3 common
- TB2-9 Optional programmable relay #3 N.C.
- TB2-10 Optional programmable relay #4 N.O.
- TB2-11 Optional programmable relay #4 common
- TB2-12 Optional programmable relay #4 N.C.
- TB2-13 Optional programmable relay #5 N.O.
- TB2-14 Optional programmable relay #5 common
- TB2-15 Optional programmable relay #5 N.C.
- TB2-16 Optional programmable relay #6 N.O.
- TB2-17 Optional programmable relay #6 common
- TB2-18 Optional programmable relay #6 N.C.
- TB2-19 Optional programmable relay #7 N.O.
- TB2-20 Optional programmable relay #7 common
- TB2-21 Optional programmable relay #7 N.C.

3.1 INSTALLATION

Power Wiring

Thread the power and motor cables through a connector into the enclosure. Strip away the motor cable insulation and apply anti-oxidation paste to the conductors.

Attach the motor cables:

- Use the T1, T2 and T3 lugs or terminals.
- Attach the power source cables:
- Use the L1, L2 and L3 lugs or terminals.

NOTE: For larger starters, thread each incoming power cable through its applicable current transformer (CT). The cables must be threaded through the CTs in the same direction to insure proper operation (Refer to the wiring diagram supplied with the starter).

The following is a list of the recommended crimp-on wire connectors manufactured by Penn-union Corp.

Wire Size	Part #	Wire Size	Part #
1/0	BLU-1/0S20	500 MCM	BLU-050S2
2/0	BLU-2/0S4	600 MCM	BLU-060S1
3/0	BLU-3/0S1	650 MCM	BLU-065S5
4/0	BLU-4/0S1	750 MCM	BLU-075S
250 MCM	BLU-025S	800 MCM	BLU-080S
300 MCM	BLU-030S	1000 MCM	BLU-100S
350 MCM	BLU-035S	1500 MCM	BLU-150S
400 MCM	BLU-040S4	2000 MCM	BLU-200s
450 MCM	BLU-045S1		

Power Factor Capacitors

Power factor correction capacitors and surge capacitors **MUST NOT** be connected between the RediStart Micro II and the motor. These devices can damage the SCR's in the package during ramping. These devices appear like a short circuit to the SCR when it turns on, which causes a di/dt level greater than the SCR can handle. If used, power factor correction capacitors or surge capacitors must be connected ahead of the RediStart Micro II. Programmable relay #2 (K6) can be set to an up-to-speed (UTS) contact (up-to-speed is the default setting) and then used to pull-in a contactor to connect the capacitors after the motor has reached full speed.

NOTE: The motor manufacturer should be contacted before surge capacitors are removed from the motor terminal box.

Electro-Mechanical Brakes

If an electro-mechanical brake is used with the RediStart Micro II, it must be powered from the line side of the starter to ensure full voltage is applied to the brake during a start so it will properly release. Programmable relay #1 (K5) can be set to a run contact (run is the default setting) and then used to pull-in a contactor to power the brake whenever the starter is providing power to the motor.

Finishing

After all of the safety precautions and installation procedures have been completed, verify that the following settings are correct for the application:

- Current transformer scaling switches.
- Hardware deceleration/braking control (JPC3).
- RediStart Micro II computer card jumpers.

Preventative Maintenance

General Information

Preventive maintenance performed on a regular basis will help ensure that the starter continues to operate reliably and safely. The frequency of preventive maintenance depends upon the type of maintenance and the installation site's environment.

NOTE: Preventive maintenance should always be performed by a trained technician.

Preventive Maintenance

During Commissioning;

- Torque all power connections during commissioning. This includes pre-wired equipment.
- Check all of the control wiring in the package for loose connections.

For the first month after the starter has been put in operation;

- Re-torque all power connections every two weeks. This includes pre-wired equipment.
- Inspect the cooling fans after two weeks to ensure proper operation.

After the first month of operation;

- Re-torque all power connections every year.
- Clean any accumulated dust from the starter using a clean source of compressed air.
- Inspect the cooling fans every three months to ensure proper operation.
- Clean or replace any air vent filters on the starter every three months.

- **NOTE:** If mechanical vibrations are present at the installation site, inspect the connections more frequently.

Ventilation Requirements

General

Provisions should be provided with the starter installation to ensure that the temperature inside the enclosure never rises above 50°C. If the temperature inside the enclosure is too high, the starter can be damaged or its life can be reduced. As a general rule of thumb, the following ventilation guidelines can be followed.

Current Range	Bottom of Enclosure	Top of Enclosure
< 200 amps	Fans or grills depending on enclosure size	
200 to 300 amps	2 x 4" grills (12 sq.in.)	2 x 4" grills (12 sq.in.)
301 to 400 amps	1 x 4" fan (115 cfm)	2 x 4" grills (12 sq.in.)
401 to 600 amps	2 x 4" fan (230 cfm)	2 x 6" grills (28 sq.in.)
601 to 700 amps	2 x 6" fan (470 cfm)	2 x 6" grills (28 sq.in.)
> 700 amps	Consult factory	Consult Factory

Benshaw installs starters under 124 amps with the heat sink protruding from the back of the enclosure. This allows a small enclosure size while still maintaining the cooling capability of the starter. The starter produces 4 watts of heat per amp of current and 14 square inches of enclosure wall are required per watt of heat generation. Contact Benshaw and ask for the enclosure sizing technical note for more information concerning starters in sealed enclosures.

Remote RTD Module

General

The RediStart Micro II can have up to 2 RTD modules installed. The RTD modules can be installed in the cabinet with the RediStart Micro II or they can be installed remotely at the motor. Refer to the Remote RTD Module manual for details on this module.

MODBUS Master Card

The MODBUS master card is installed on the RediStart Micro II CPU card to allow the starter to communicate with the RTD Module.

3.1 INSTALLATION

CT Mounting

General

On larger horsepower starters, the current transformers have to be installed on the power wire. To ensure that the CT is not damaged by rubbing on the power lug, the CT should be tie wrapped to the power wire 3 inches from power lug using 2 tie wraps in a cross pattern. Refer to the following diagram. The CTs must be installed so that the white dot is facing the LINE side of the starter with the proper CT installed for each phase. The metering functions will not work correctly if the CTs are not installed correctly.

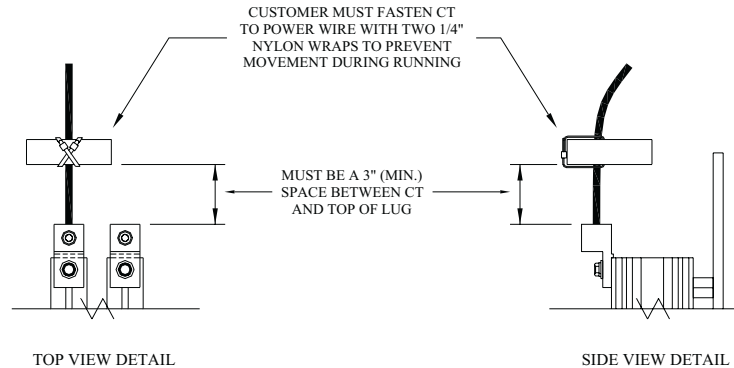

CT Ratio Scaling

General Information

The motor current signal scaling is set according to the motor current specified when the starter is ordered. To ensure accurate operation, the motor current signal must be correctly scaled for the motor current being controlled by the starter. Motor current signal scaling may have to be changed if the motor size has been changed from the original specification. Motor current signal scaling is accomplished by verifying the current transformer ratio as supplied with the starter and then selecting the correct DIP switch setting from the chart on the following page for the current transformer ratio.

The DIP switches are:

- ON in the right position
- OFF in the left position

NOTE: Adjust the DIP switches only when the motor is stopped, or the switches could be damaged.

Confirm Switch Settings

To verify or change the motor current signal scaling:

- Compare the CT ratio stamped on each CT to the CT ratio listed on the wiring diagram supplied with the starter to ensure the correct CTs are installed.
- Inspect the RediStart Micro II power card to ensure that the DIP switches are in the correct positions for the applicable CT ratio and the motor full-load current (FLA) rating.

3.1 INSTALLATION

Switch Settings	CT Ratio	Motor FLA	Switch 1	Switch 2
	288:1	3A to 9A	Off	Off
	288:1	9A to 24A	On	Off
	288:1	25A to 60A	On	On
	864:1	20A to 24A	Off	Off
	864:1	25A to 70A	On	Off
	864:1	71A to 180A	On	On
	2640:1	40A to 80A	Off	Off
	2640:1	81A to 200A	On	Off
	2640:1	201A to 500A	On	On
	5760:1	70A to 160A	Off	Off
	5760:1	161A to 400A	On	Off
	5760:1	401A to 1200A	On	On

- Changing FLA** If the actual motor FLA has been changed from the motor FLA documented on the purchase order:
- The DIP switch positions may need to be changed.
 - Different CTs may have to be installed in the starter and the current transformer ratio parameter may need to be changed (Refer to current transformer ratio parameter, page 98).

RediStart Micro II Computer Card Jumpers

General Information The RediStart Micro II computer card has a number of jumpers that affect the operation of the starter. In some cases, these jumpers will over-ride the programmed values.

JPC5 - LCD Start button The LCD Start button can be enabled or disabled by this jumper. The LCD Start button is factory enabled unless the purchase order requests that the LCD Start button is disabled. The LCD Start button is controlled by jumper JPC5 on the RediStart Micro II computer card (Refer to RediStart Micro II computer card layout on page 118).

Mode	Position
Enable	1-2
Disable	2-3

JPC7 - Overload Auto/Man. The motor thermal overload can be set to require a manual reset or to automatically reset after a thermal trip. The motor thermal overload is set to the manual reset position unless the purchase order requests that the motor thermal overload is set to the automatic reset position. The motor thermal overload reset is controlled by jumper JPC7 on the RediStart Micro II computer card (Refer to RediStart Micro II computer card layout on page 118).

Mode	Position
Automatic Reset	1-2
Manual Reset	2-3

JPC13 - LCD Stop Button The LCD Stop button can be enabled or disabled by this jumper. The LCD Stop button is factory enabled unless the purchase order requests that the LCD Stop button is disabled. The LCD Stop button is controlled by jumper JPC13 on the RediStart Micro II computer card (Refer to RediStart Micro II computer card layout on page 118).

Mode	Position
Enable	1-2
Disable	2-3

3.1 INSTALLATION

JPC17 - Forward Bypass

The RediStart Micro II can be set to monitor a forward bypass contactor. This jumper will allow the RediStart Micro II to monitor a bypass contactor that operates when the starter is running in the forward direction. The RediStart Micro II takes the contactor feedback from an auxiliary contact connected between terminals 3 and 4 of JPC3 on the computer card or from the wiring connection to the integral bypass circuit card. The forward bypass monitoring jumper is set to the disabled position unless the starter is equipped with a factory installed bypass contactor. The forward bypass monitoring is controlled by jumper JPC17 on the RediStart Micro II computer card (Refer to RediStart Micro II computer card layout on page 118).

Mode	Position
Forward Bypass monitoring	1-2
No Forward Bypass monitoring	2-3

JPC19 - Fault Reset

The RediStart Micro II can be set to either require a manual reset or automatically reset after a fault occurs. The RediStart Micro II is set for manual fault reset unless the purchase order requests that the fault reset jumper is set to automatic. The fault reset is controlled by jumper JPC19 on the RediStart Micro II computer card (Refer to RediStart Micro II computer card layout on page 118).

Mode	Position
Automatic Fault Reset	1-2
Manual Fault Reset	2-3

The automatic fault reset works in conjunction with the # auto resets parameter (see page 83) and the Fault Classes sub-menu (see page 84).

The # auto resets parameter sets how many non-critical faults will be reset in one hour. Once this number has been reached, the starter will not automatically reset the next fault. When this occurs, the user should check the event recorder for the cause of the faults and correct the problem.

The fault classes sub-menu allows the user to set faults as critical, non-critical, disabled, warning relay A, warning relay B or warning relay C. When JPC19 is set to automatic fault reset and a fault is set to non-critical, the RediStart Micro II will automatically reset the fault.

4.

OPERATION

4.1 OPERATION

Main Display Messages

General

During normal operation, the RediStart Micro II can show a number of different operating messages on the display. These messages give information on the present operating state of the starter and motor. There are three locations where messages are displayed as shown in the following diagram.

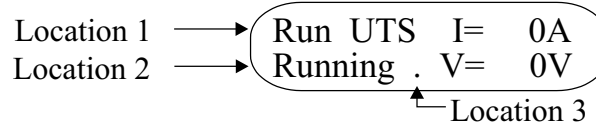

Messages

The messages, display locations and descriptions are as follows:

Message	Location	Description
Stop	1	Starter is in a stopped state.
Coast	1	Starter coasting between direction changes.
BKS hld	1	Backspin timer is active.
TBS hld	1	Time between starts is active.
SPH hld	1	Starts per hour is active.
BKS LOC	1	Backspin timer is locked.
TBS LOC	1	Time between starts counter has locked.
SPH LOC	1	Starts per hour counter has locked.
JOG	1	Starter is operating in the jog at set speed mode.
RUN	1	Starter is applying power to motor.
Stopping	1	Stop command was applied, motor is being stopped.
RUN UTS	1	Starter is running and motor is at full speed.
RUN SYN	1	Starter is running and motor is synchronized.
XXX.Xmin	2	Next start cannot be performed for xxx.x min.
PH Err	2	The phase order is incorrect.
Freq Err	2	The line frequency is outside of the trip settings.
Volt Err	2	The line voltage is outside of the trip settings.
OCT Trip	2	Motor current went above the over current trip setting.
UCT Trip	2	Motor current went below the under current trip setting.
GDF Trip	2	A ground fault was detected.
Door In	2	The Disconnect switch is open.
No Line	2	Line voltage is not present.
OL Warn	2	Motor thermal overload is over 90% content.
OL Trip	2	Motor thermal overload is tripped and reset is allowed.
OL Lock	2	Motor thermal overload tripped and reset is not allowed.
Ready	2	All conditions OK to run.
Accel	2	Starter is ramping.
Accel 2	2	Starter is ramping using 2nd ramp profile.
Running	2	Starter ramp profile is complete.
FWD Acc	2	The motor is being accelerated in the forward direction.
REV Acc	2	The motor is being accelerated in the reverse direction.
Forward	2	The motor is running in the forward direction.
Reverse	2	The motor is running in the reverse direction.
LS Acc	2	The motor is being accelerated in low speed.
HS Acc	2	The motor is being accelerating in high speed.
Low Sp	2	The motor is running in low speed.
High Sp	2	The motor is running in high speed.
Kicking	2	Starter is applying kick start current.
Kicking 2	2	Starter is kicking using 2nd ramp profile.
Decel	2	Motor is decelerating.
Braking	2	The motor is being braked.
FWD Jog	2	Motor is jogging in the forward direction.
REV Jog	2	Motor is jogging in the reverse direction.
ComLoss	2	Modbus communications lockout.
EN Save	2	Energy saver is active.
Heater	2	The motor heater is operating.
RTD Alar	2	A RTD went over its alarm setting.
RTD ComF	2	Communications with an RTD module was lost.
RTD Open	2	A RTD is detected as being open.
RTD Shor	2	A RTD is detected as being shorted.
RTD Warn	2	A RTD went over its warning setting.

If Lock	2	Starter is providing set maximum field current.
If CTRL	2	Starter is in field current control mode.
PF CTRL	2	Starter is in power factor control mode.
TachLoss	2	The tachometer feedback signal was lost.
PORT	2	The starter is in Power Outage Ride-Through mode.
. (dot)	3	Password protection is enabled.

Meter Display Pages

General

Besides the main display, the RediStart Micro II has a number of other display pages that show various operational values. By pressing the Up or Down arrow buttons, it is possible for the user to view all operational information without having to enter the menu system. The display pages are described below in the order they appear when pressing the Up button.

NOTE: Not every display page shown here may be present depending on the options provided with the starter.

Current Page

The current meter page displays the currents for all three phases.

```

Phase 1 Current → ( Current I2= 0A ← Phase 2 Current
                   I1= 0 I3= 0A ← Phase 3 Current
  
```

Voltage Page

The voltage page displays the voltages for all three phases.

```

Phase 1 Voltage → ( Voltage V2= 0V ← Phase 2 Voltage
                   V1= 0 V3= 0V ← Phase 3 Voltage
  
```

Kilo-Watt Hour Page

The Kilo-Watt Hour power page displays the true power measurements for the motor.

```

(KWatt Hour= 0.0H ← Kilo-Watt Hours
 MWatt Hour= 0.0H ← Mega-Watt Hours
  
```

Power Page

The power page displays the KW and kVA power measurements for the motor.

```

(KWatts = 0.0W ← Kilo-Watts
 KVA Usage = 0.0 ← KVA
  
```

Tru Torque Page

The tru torque page displays the Tru Torque % and Power Factor measurements for the motor.

```

(Tru Torq% = 0.0% ← True Torque
 Motor pf = 1.0 ← Power Factor
  
```

4.1 OPERATION

Runtime Page The runtime page displays the runtime on the motor.

RunTime Hr= 123h ← Operating Hours
HoursX100 = 1.2 ← Hundreds of Hours

User Counts Page The user counts page displays the user resettable runtime and number of starts.

User RT Hr= 123h ← User Resettable Run time
User Start= 45# ← User Resettable Starts

Motor #1 Page The motor #1 page displays the motor current imbalance as a percentage and the number of motor starts.

Curr. Imba= 3% ← Current Imbalance
Starts = 45 ← Number of Starts

Motor #2 Page The motor #2 page displays overload content and ground fault current information.

% Overload= 3% ← Overload Content
Ground Fau= 0A ← Ground Fault Current

Motor #3 Page The motor #3 page displays operating frequency and motor power factor information.

Frequency= 60.0 ← Line Frequency
Motor PF = 1.00 ← Power Factor

Sync Page The sync page gives the synchronous motor field current and slip.

Field Amps= 0.0A ← Field Current
% Rotor Sl=99.9% ← Slip Percentage

Communications Page The communications page displays the communications statistics.

Communication Rate → Com's Tx= 0# ← # of Transmits
Cr= 0 Rx= 0# ← # of Receives

RTD #1 & #2 Temp. The RTD #1 & #2 temperature page displays the temperatures those RTDs are measuring.

RTD#1 = 90C ← RTD #1 Temperature
RTD#2 = 80C ← RTD #2 Temperature

RTD #3 & #4 Temp.

The RTD #3 & #4 temperature page displays the temperatures those RTDs are measuring.

RTD#3	=	90C	← RTD #3 Temperature
RTD#4	=	80C	← RTD #4 Temperature

RTD #5 & #6 Temp.

The RTD #5 & #6 temperature page displays the temperatures those RTDs are measuring.

RTD#5	=	90C	← RTD #5 Temperature
RTD#6	=	80C	← RTD #6 Temperature

RTD #7 & #8 Temp.

The RTD #7 & #8 temperature page displays the temperatures those RTDs are measuring.

RTD#7	=	90C	← RTD #7 Temperature
RTD#8	=	80C	← RTD #8 Temperature

RTD #9 & #10 Temp.

The RTD #9 & #10 temperature page displays the temperatures those RTDs are measuring.

RTD#9	=	90C	← RTD #9 Temperature
RTD#10	=	80C	← RTD #10 Temperature

RTD #11 & #12 Temp.

The RTD #11 & #12 temperature page displays the temperatures those RTDs are measuring.

RTD#11	=	90C	← RTD #11 Temperature
RTD#12	=	80C	← RTD #12 Temperature

RTD #13 & #14 Temp.

The RTD #13 & #14 temperature page displays the temperatures those RTDs are measuring.

RTD#13	=	90C	← RTD #13 Temperature
RTD#14	=	80C	← RTD #14 Temperature

RTD #15 & #16 Temp.

The RTD #15 & #16 temperature page displays the temperatures those RTDs are measuring.

RTD#15	=	90C	← RTD #15 Temperature
RTD#16	=	80C	← RTD #16 Temperature

4.1 OPERATION

Max. RTD Temp.

The maximum RTD temperature page displays the temperature and RTD number from the highest measuring RTD.

Max of All= 90C ← Max. RTD Temperature
M All RTD#= 5# ← RTD Number

Max. Bearing RTD Temp.

The maximum bearing RTD temperature page displays the temperature and RTD number from the highest measuring RTD in the bearing group.

Max Bearin= 90C ← Max. Bearing Temp.
M Bea RTD#= 5# ← Bearing RTD Number

Max. Stator RTD Temp.

The maximum stator RTD temperature page displays the temperature and RTD number from the highest measuring RTD in the stator group.

Max Stator= 90C ← Max. Stator Temp.
M Sta RTD#= 5# ← Stator RTD Number

Peak RTD Temp.

The peak RTD temperature page displays the highest peak temperature reached and the number of the RTD that read the temperature.

Peak of Al= 90C ← Peak RTD Temp.
P All RTD#= 5# ← RTD Number

Peak Bearing RTD Temp.

The peak bearing RTD temperature page displays the highest bearing temperature reached and the number of the RTD that read the temperature.

Peak Beari= 90C ← Peak Bearing Temp.
P Bea RTD#= 5# ← Bearing RTD Number

Peak Stator RTD Temp.

The peak stator RTD temperature page displays the highest stator temperature reached and the number of the RTD that read the temperature.

Peak Stato= 90C ← Peak Stator Temp.
P Sta RTD#= 5# ← Stator RTD Number

Parameters

Parameter Usage The description and use of each parameter is described in the programming section of the manual. Most parameters are fairly straightforward and don't require any further explanation. The rest of this chapter gives a more detailed description of the use of the parameters that are more complicated to use.

Starter Modes

Description The Starter Mode sub menu (see page 54) contains parameters for selecting the type of start and stop to perform. By allowing the user to select the start and stop mode the system can be operated in the optimal start and stop fashion for the load. Below are the available modes along with some examples for typical applications.

Start Modes **Curr (Current Ramp):** The current ramp is ideal for most general-purpose motor control applications; Examples: crushers, ball mills, compressors, saws, and centrifuges).

The Current Ramp applies to the following in the Starter Setup Main Menu:
Forward1 Profile, Forward2 Profile, Reverse1 Profile, and Reverse2 Profile.

TT (Tru Torque): The true torque ramp is suitable for applications that require a minimum of torque transients during starting or for consistently loaded applications that require a reduction of torque surges during starting; Examples: pumps, fans, and belt driven equipment).

The Tru Torque ramp applies to the following in the Starter Setup Main Menu:
True Torque Ramp

Tach (Tachometer Feedback): The tachometer feedback ramp is for applications where torque transients must be held to a minimum, and the starting load is unknown, vary, or change during the start cycle; Examples: Belts, and conveyors.

The Tachometer ramp applies to the following in the Starter Setup Main Menu:
Tachometer Setup

Stop Modes **Coas (Coast):** A coast stop should be used when no special stopping requirements are necessary; Example: crushers, balls mills, centrifuges, belts, conveyor.

There is no menu that applies in the Starter Setup Main Menu.

VDCL (S Curve Voltage Deceleration): A standard open loop S-Curve voltage deceleration is best suited for applications such as pumps and compressors.

The S Curve Voltage Deceleration applies to the following in the Starter Setup Main Menu: Decel Setup

TT (Tru Torque): The true torque deceleration is best suited to pumping and compressor applications where pressure surges during a stop must be eliminated. This setup is easier than the S-Curve Voltage Deceleration and is less source voltage dependent.

The Tru Torque deceleration applies to the following in the Starter Setup Main Menu:
True Torque Ramp

Brak (Brake): The Brake stop mode allows a static DC field to be injected into the stator of the motor, which makes the rotor stop in a fashion similar to the way the 3 phase rotating magnetic field brings the motor up to operating speed; Examples: saws, E-Stop applications, machine tools, and large centrifugal loads.

The Brake deceleration applies to the following in the Starter Setup Main Menu:
Brake Ctl Setup

4.1 OPERATION

Current Ramp Adjustment

Current Ramp

The current ramp sets how the motor accelerates. The current ramp is a linear increase in current from the initial setting to the maximum setting. The ramp time sets the speed of this linear current increase. The following figure shows the relationships of these different ramp settings.

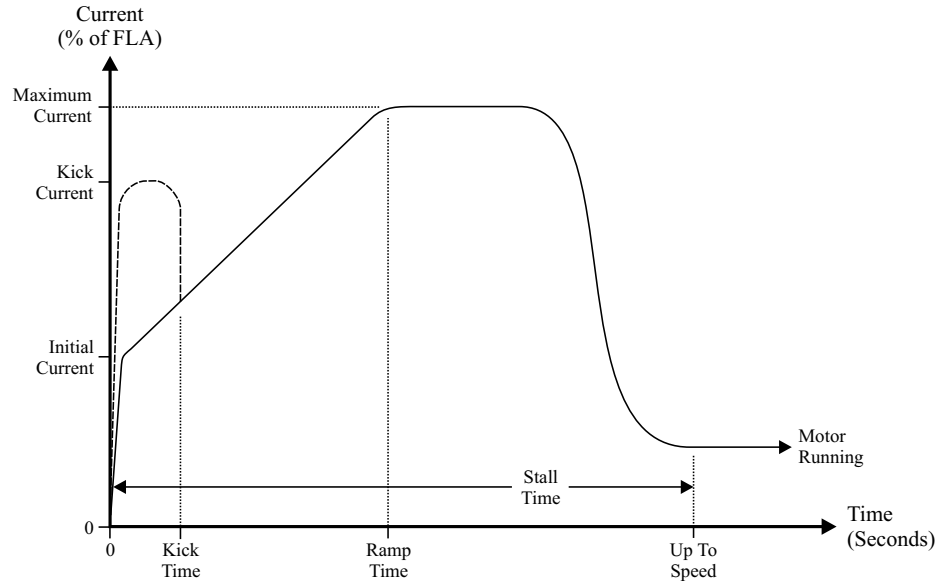

Initial Current Setting

The initial current should be set to the level that allows the motor to begin rotating within a couple of seconds of receiving a start command.

To adjust the initial current setting give the starter a run command. Observe the motor to see how long it takes before it begins rotating and then stop the unit. For every second that the motor doesn't rotate, increase the initial current by 20%. Typical loads will require an initial current in the 50% to 175% range.

Maximum Current Setting

For most applications, the maximum current can be left at 600%. This will ensure that enough current is applied to the motor to accelerate it to full speed.

The maximum current can also be set to a lower current limit. This is usually done to limit the voltage drop on the power system or to limit the torque the motor produces to help prevent damage to the driven load.

NOTE: The motor may achieve full speed at any time during the current ramp. This means that the maximum current setting may not be reached. Therefore, the maximum current setting is the most current that could ever reach the motor, and not necessarily the maximum current that will reach the motor.

NOTE: When setting a current limit, the motor must be monitored to ensure that the current is high enough to allow the motor to reach full speed under worst case load conditions.

Ramp Time Setting

The ramp time is the time it takes for the current to go from the initial current to the maximum current. To make the motor accelerate faster, decrease the ramp time. To make the motor accelerate slower, increase the ramp time.

If the ramp time expires before the motor reaches full speed, the starter will maintain the set maximum current level until either the motor reaches full speed, the stall time expires, or the motor thermal overload trips.

NOTE: Setting the ramp time to a specific value does not necessarily mean that the motor will take this time to accelerate to full speed. The motor and load may achieve full speed before the ramp time expires if the application does not require the set ramp time and maximum current to reach full speed. Alternatively, the motor and load may take longer than the set ramp time to achieve full speed.

Programming A Kick Current

General

The kick current sets a current level that overrides the current ramp when a start is first commanded. The kick current is only useful on motor loads that are hard to get rotating but then are much easier to move once they are rotating. An example of a load which is hard to get rotating is a ball mill. The ball mill requires a high torque to get it to rotate the first quarter turn (90°). Once the ball mill is past 90° of rotation, the material inside will begin tumbling and it is easier to turn.

Kick Current

The kick current parameter is usually set to a low value and then the kick time is adjusted to get the motor rotating. If the kick time is set to more than 2.0 seconds without the motor rotating, increase the kick current by 100% and re-adjust the kick time.

Kick Time

The kick time adjustment should begin at 0.5 seconds and be adjusted by 0.1 or 0.2 second intervals until the motor begins rotating. If the kick time is adjusted above 2.0 seconds without the motor rotating, start over with a higher kick current setting.

Jog at Set Speed

Description

The jog at set speed allows the motor to be operated at fixed low speeds. It is possible to operate the motor at fixed speeds of 7%, 14% and 20% of full speed.

Forward Jog

The motor can be jogged in the forward direction at fixed speeds of 7% or 14% of full speed. To make the motor jog in the forward direction, the starter must be told to jog the motor by energizing the jog input. Then, the starter must be given a run command to actually operate. Energize the jog input by applying 120VAC to terminal 4 of the JC13 terminal block on the RediStart Micro II computer card(see computer card layout on page 118)

The jog speed is set by the forward speed parameter (see page 60)

Jog Current

The jog current sets the level of current reaching the motor when it is being jogged. A motor will heat up more when it is being jogged since the speed is too low for the cooling fan to move any air over the motor. Therefore, the jog current should be set to the lowest possible level that will still rotate the motor. This will prevent excessive heating of the motor.

Kick Current

The jog at set speed produces lower starting torque than running torque. Often, with low jog currents, the motor will produce enough torque to keep the motor turning but it won't produce enough torque to start it. The kick current can be used to start the load rotating to overcome this. Start with the kick current at a middle level and increase it in 50% increments if the current is not enough.

4.1 OPERATION

Kick Time

The kick time setting in the jog sub-menu sets the time that the kick current is applied. If a kick current is required, start with a 0.5 second time and continue to increase the time until the load will rotate.

Tachometer Feedback

Description

The Tachometer control ramp profile (see page 61) provides a method to linearly ramp the speed of the system. When this control mode is selected, the starter uses a tachometer to provide speed feedback to the starter. This mode is commonly used on conveyor belt applications where a smooth controlled start is necessary under various load conditions to prevent belt breakage, lifting, or excessive stretching. The Tachometer controller consists of an inner PID current loop and an outer PI speed control loop.

NOTE: The maximum current limit will override the speed control loop if necessary. If the Maximum Current level is not set high enough or the load is too great, the RediStart Micro II starter will limit the motor current to this maximum level. When current limiting occurs, the speed profile will no longer be linear and the motor(s) will take longer to accelerate to full speed. Therefore, if current limiting is undesirable, this parameter must be set higher than the peak starting current during a linear speed ramp start.

Tachometer Requirements

In addition to the basic motor and starter setup variables, the following needs to be done to use the tachometer feedback control ramp:

1. Connect a tachometer with appropriate DC output voltage and correct polarity to the RediStart Micro II power card input (terminal TBP13).
2. The tachometer feedback Start Mode is selectable as "Tach" from the Starter Modes menu.
3. Program the appropriate variables in the Tachometer Setup menu.
4. Set the Initial Current level in either the Quick Start menu or the Forward1 Profile menu to the desired current limit.
5. Set the Maximum Current level in either the Quick Start menu or the Forward1 Profile menu to the desired maximum current limit.

Programming The Motor Deceleration

Deceleration Control

The standard deceleration control on the RediStart Micro II uses an open loop voltage ramp. The RediStart Micro II will ramp the voltage down to decelerate the motor. The curve shows the motor voltage vs the decel setting.

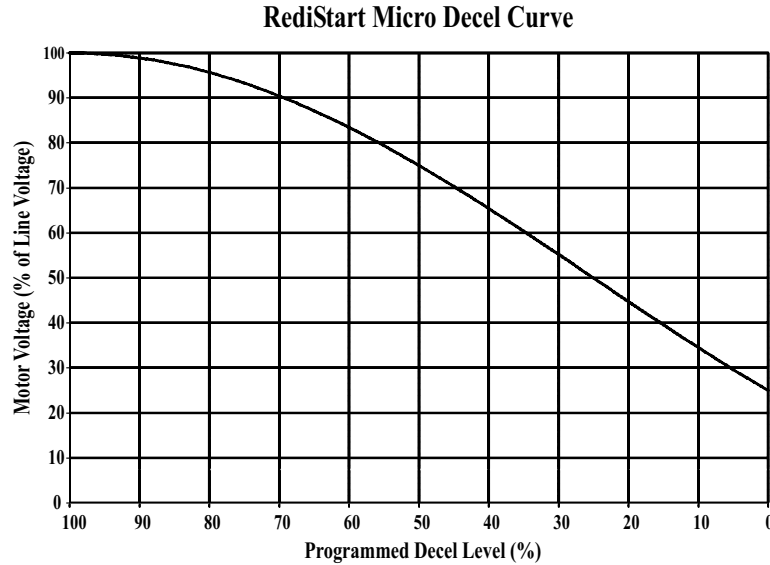

Decel Level 1

This sets the starting voltage of the deceleration ramp. Most motors require the voltage to drop to around 60% or lower before any significant deceleration is observed. Therefore, a good first setting for this parameter is 35%.

To adjust this parameter, it is necessary to observe the motor operation as soon as a stop is commanded. If the motor hunts (speed oscillations) at the beginning of the deceleration, then lower the parameter by 5%. If the motor has a big drop in speed as soon as a stop is commanded, then raise the parameter by 5%.

Some motors are very sensitive to the adjustment of this parameter. If a 5% adjustment changes the motor from hunting to dropping in speed, then a smaller change of 1% or 2% may be necessary.

Decel Level 2

This sets the final voltage for the deceleration ramp. In most cases, this parameter can be set to 10% and the decel time can be used to adjust the deceleration rate. If the motor is coming to a stop too quickly or if the starter continues to apply current to the motor after the motor has stopped, this parameter can be increased in 5% increments to fix this.

Decel Time

The decel time sets how quickly the motor decelerates. Usually a time of 30 seconds is a good starting point. To make the motor take longer to decelerate, increase this parameter or to make the motor decelerate quicker, decrease this parameter.

4.1 OPERATION

PORT (Power Outage Ride Through)

Description

The Power Outage Ride Through capability (see page 67) allows the starter to ride through short duration brown outs, single phase, and power loss conditions.

When the system senses a voltage disturbance in a time frame greater than the Sense Time parameter, the power will be removed from the motor for a coast to stop, and the Fault Dly timer will begin to time; if it is not set to OFF.

If the power disturbance ends before the programmed Fault Dly time, the motor will restart -- if a start command is still present -- from initial to maximum current in the specified ramp time.

If the outage lasts longer than the programmed Fault Dly time, the starter will issue a Fault 98; "No Mains PWR."

If Fault Dly is set to OFF, the starter will use the standard motor protection fault delay timers to sense power disturbances.

NOTE: Starts/Hou (starters per hour), Time Start (time between starts), and BKS Timer (backspin timer) are not incremented for PORT.

NOTE: If the system Start Mode parameter is programmed with a tachometer ramp, the system will restart using a tachometer ramp.

Bypass Delay

PORT can also hold a bypass contactor in for a programmed BYP Dly when the power disturbance is Sensed.

NOTE: The BYP Dly is fixed at 0.0 seconds to protect systems that contain an integral bypass card.



NOTE: Caution must be taken when the BYP Dly is set above 0.0 seconds. If the bypass contactor is energized when the power disturbance ends, the motor will start across the line. The resulting torque may damage the system.

PORT Detection

The starter can be detected in PORT operation by monitor of the PORT relay output; Selectable on any of the programmable relays. Once programmed, this relay can be used to feed 120VAC to input 9 of the JC13 terminal block on the computer card. This causes the system to use the Forward/Reverse2 Profile for starting the motor.

TruTorque Acceleration Ramp

TruTorque Ramp

The TruTorque ramp sub-menu (see page 68) contains the parameters that are used to activate and tune TruTorque Acceleration and Deceleration Control.

The primary purpose of TruTorque Control is to reduce the torque surge that occurs as an AC induction motor comes up to full speed. This torque surge can be a problem in applications especially in pumps and belt driven applications. In pumping applications this torque surge results in a pressure peak as the motor comes up to speed. In most situations this small pressure peak is not a problem. However in selected cases, even a small pressure peak can be highly undesirable. In belt drive applications, TruTorque prevents the slipping of belts as the motor reaches full speed.

Note: When TruTorque acceleration control is enabled the second ramp (Ramp #2) and Kick Current functions are disabled.

TruTorque control can be very useful for a variety of applications. However it is best used for pump and other variable torque applications. TruTorque generally should not be used in applications where the starting load varies greatly from one start to another.

Initial Torque	<p>This value sets the initial torque value for the motor. The initial torque level should be set to a level that allows the motor to begin rotating within a couple of seconds of receiving a start command. Typical loads will require values between 10% to 30%</p> <p>If the value is set too high a current surge may result. If the value is set too low a “No current at Run” fault may occur.</p>
Maximum Torque	<p>This value sets the final torque reference value at the end of the ramp time. Typical loads require a value around 100-110%. If the load is less than motor rating then the maximum torque value can be decreased. If the load is hard to start or the motor is a NEMA C or D type motor then this value may need to be increased.</p> <p>If the motor reaches full speed too quickly then decrease the Maximum Torque value by 5% and retest. If the motor does not achieve full speed, increase the Maximum Torque value by 10% and retest.</p> <p>If the motor can be started either by using default TruTorque values or current ramp control, the Maximum Torque value can be more precisely determined so that the motor comes up to speed in approximately the preset Ramp Time. In this case, while the motor is running at full load, display the TT% meter on the display (see Meter Setup for information on how to display the TT% meter). Record the value displayed when the motor is running with full load. The Maximum Torque value should then be set to the recorded running value of TT% plus an additional 10%. Retest with this value to verify correct operation.</p> <p>Note: When setting the Maximum Torque value the motor must be monitored to ensure that the torque is high enough to allow the motor to reach full speed under worst case load conditions.</p>
Ramp Time	<p>The Ramp Time setting is the time it takes for the torque to go from the Initial Torque Setting to the Maximum Torque Setting. To make the motor accelerate faster, decrease the ramp time. To make the motor accelerate slower, increase the ramp time.</p> <p>If the ramp time expires before the motor reaches full speed the starter will maintain the set Maximum Torque level until either the motor reaches full speed, the stall (UTS) timer expires, or the motor thermal overload trips.</p> <p>Note: Setting the ramp time to a specific value does not necessarily mean that the motor will take this time to accelerate to full speed. The motor and load may achieve full speed before the ramp time expires if the application does not require the set ramp time and maximum torque to reach full speed. Alternatively, the motor and load may take longer than the set ramp time to achieve full speed.</p>

TruTorque Deceleration Ramp

General	<p>The TruTorque ramp sub-menu (see page 68) contains the parameters that activate TruTorque Acceleration and Deceleration Control.</p> <p>TruTorque deceleration is a closed-loop deceleration control. The RediStart MicroII will ramp down the torque to smoothly decelerate the motor. TruTorque deceleration is very simple to setup.</p>
TruTorque Decel Mode	<p>As a default deceleration control will be an open-loop voltage ramp. TruTorque Decel Mode needs to be turned on to utilize TruTorque deceleration control. When TruTorque deceleration is enabled the TruTorque deceleration settings listed below will be used for deceleration control.</p>

4.1 OPERATION

TT End Decel Torque

The value sets the final torque level for the TruTorque deceleration ramp. In most cases, this parameter can be set to 10%.

To adjust this parameter, it is necessary to observe the motor. If the motor is coming to a stop too quickly or if the starter continues to apply current to the motor after the motor has stopped this parameter can be increased in 5% increments.

If the motor is still rotating when the desired deceleration time has expired, decrease this parameter by 5% and retest.

TT Decel Ramp Time

The TruTorque deceleration time sets how quickly the motor decelerates. Usually a time of 30 seconds is a good starting point. To make the motor decelerate at a slower rate increase this time or to make the motor stop quicker decrease this time.

How Fault Classes Work

General

The Fault classes sub-menu (see page 84) allows the starter behavior for different faults to be altered. There are six different options that a fault can be set to. These options are described in the following paragraphs. See page 108 for a complete fault code and description listing.

NonC

Non-critical fault. If this fault occurs, the starter will shut down and display the fault number and description on the display. A non-critical fault can be set to either require a manual reset or to automatically reset.

The automatic resetting of a non-critical fault is dependant on the automatic computer reset jumper JPC19 (see page 26). When JPC19 is set to auto reset (position 1-2), the starter will automatically reset the fault. The number of automatic resets parameter (# Auto RST) on page 83 sets how many times the starter will perform this automatic reset sequence in one hour.

Crit

Critical fault. If this fault occurs, the starter will shut down and display the fault number and description on the display. To clear the fault, the computer reset button must be pressed or the control power to the starter cycled.

Dis

Fault is Disabled. If this fault occurs, the starter will ignore the fault and continue to operate.

WrnA

Fault warning relay A. If this fault occurs, the starter will continue to operate. If a programmable relay is programmed to WrnA, that relay will be energized when the fault occurs. The WrnA relay can be assigned to as many different faults as the user requires.

WrnB

Fault warning relay B. If this fault occurs, the starter will continue to operate. If a programmable relay is programmed to WrnB, that relay will be energized when the fault occurs. The WrnB relay can be assigned to as many different faults as the user requires.

WrnC

Fault warning relay C. If this fault occurs, the starter will continue to operate. If a programmable relay is programmed to WrnC, that relay will be energized when the fault occurs. The WrnC relay can be assigned to as many different faults as the user requires.

Use of Overcurrent and Undercurrent

General	For the over current and undercurrent trips, there are settings for the current level and the detect time. The motor current must go above or below the current level settings for the detect time before the overcurrent or undercurrent condition is detected. The overcurrent and undercurrent trips do not become active until the starter is up-to-speed (UTS is shown in top line of display).
Overcurrent	The overcurrent parameters are for the user to set a user defined high current trip. The overcurrent parameters are not used for the thermal overload. If the driven load can be damaged by the full motor torque being applied during a stall or jam of the driven load, the over-current should be used to prevent this.
Undercurrent	The undercurrent parameters are used to set a user defined low current trip. The undercurrent parameters are used to protect a driven load from running empty. A good example of the undercurrent trip usage is a water pump. If the pump can run dry, the undercurrent parameters can be set to detect the low current and shut the pump down. To use this, the current could be set to 50% and the detect delay to 5 seconds to shut the pump down 5 seconds after the current falls below 50% of the motor FLA parameter.
Activating a Relay	To make the starter activate a relay when an overcorrect or undercurrent is detected, a programmable relay must be programmed to OCT or UCT respectively.
Tripping vs Running	<p>As the default, the starter will trip when an over-current or undercurrent is detected. To keep the starter operating, the over-current fault (fault #78) or undercurrent fault (fault #79) must be set to dis (disabled) in the fault classes sub-menu (see page 84) to turn off the fault trip.</p> <p>Once the over-current or undercurrent fault is disabled, the starter will not trip when the over-current or undercurrent condition is detected, The relay programmed to OCT or UCT will still operate when the condition is detected. Once the condition clears, the relay will remain active for the programmed release delay time. The user must monitor the relay output and take appropriate action when the relay is energized.</p>

Overload

General	The RediStart Micro II comes with a programmable overload that allows classes 1-40 to be programmed plus an overload disable and overload bypass during starting. The thermal overload is displayed as a percentage of overload used, with 0% representing a “cold” overload and 100% representing a “tripped” overload. The overload always operates on the highest phase current.
Overload Classes	The overload class sets the time it takes for the overload to trip when the motor current is six (6) times the motor FLA. The overload follows an exponential curve that gives a long trip time for slight overloads and a short trip time for large overloads. This models the heating of a typical squirrel cage induction motor. See page 11 for the motor thermal overload curves.

4.1 OPERATION

Overload Operation

There are two ways that the overload can operate. The operation is changed in the fault classes sub-menu by changing the overload lock fault (fault #90) from Crit to Dis.

When fault #90 is set to Crit;

- The overload warning relay will energize when the O/L content goes above 90% and de-energize when the O/L content goes back below 80%.
- The starter will shut down if the overload content reaches 100%.
- The overload lock relay will energize when the O/L content reaches 100% and de-energize when the O/L content goes back below 60%.
- The starter will not allow an overload reset once the overload trips until the overload content goes back below 60%.
- The overload relay will energize when the overload trips and will de-energize when the overload condition is cleared by an automatic or manual reset.

When fault #90 is set to Dis;

- The overload warning relay will energize if the overload content goes above 90% and will de-energize when the overload content goes back below 80%.
- The starter will not shut if the overload content reaches 100%.
- The overload lock relay will never energize.
- The overload relay will energize when the overload content goes above 100% and will de-energize when the overload content goes back below 100%.

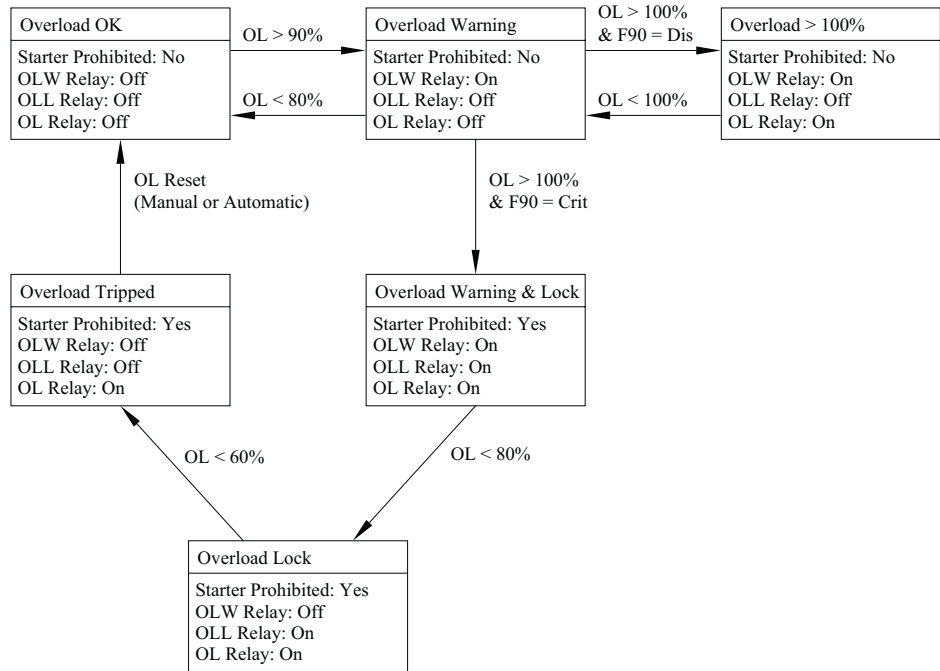

Running Overload

When the RediStart Micro II is running the overload content will never discharge below 30%. The overload content will always hold at any value below 30% during the running period. As soon as the unit is stopped the overload will begin to discharge back to 0%.

Resolving Overload Trips

The National Electrical Code, article 430 Part C, allows for different overload multiplier factors depending on the motor and operating conditions.

NEC section 430-32 outlines the allowable service factor (Serv. Fact) for different motors as follows:

Motor	Overload Multiplier
Service factor 1.15 or more	1.25
Motor temp. rise 40°C or less	1.25
All others	1.15

NEC section 430-34 permits further modifications if the service factor (Serv. Fact) is not sufficient to start the motor:

Motor	Overload Multiplier
Service factor 1.15 or more	1.40
Motor temp. rise 40°C or less	1.40
All others	1.30

Although the NEC doesn't address the effect of the ambient temperature of the motor location, guidance can be derived by examining NEC limits. If the motor is operating in an ambient temperature that is less than 40°C, then the overload multiplier can be increased while still protecting the motor from exceeding its maximum designed temperature. The following curve gives the ambient temperature vs the correction factor.

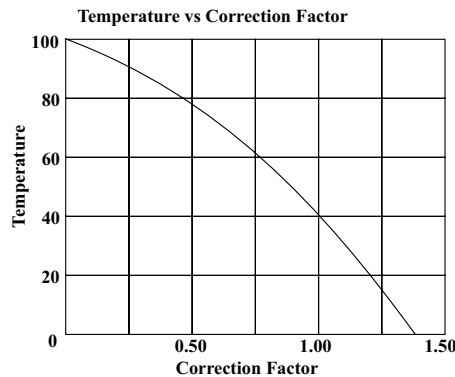

Example: If a motor operates at 0°C then a 1.36 correction factor could be applied to the overload multiplier. This could give a theoretical overload multiplier of 1.36×1.25 or 1.70. The highest legal value of overload multiplier is 1.40 so this could be used.

Performing an Emergency Restart

General

The RediStart Micro II has an emergency restart feature which allows the user to override any lock-outs that are present. This feature should only be used in an emergency. Before an emergency reset is performed, the reason for the lock-out and the condition of the motor should be examined to ensure that the motor is capable of being re-started without causing any damage.

Performing a Reset

Place a jumper between pins 6 and 11 of JC11 on the computer card. Hold the Enter button on the display and press the thermal overload reset pushbutton until a microprocessor reset occurs.

4.1 OPERATION

5.

PROGRAMMING

5.1 PROGRAMMING: How To Program

Menu Buttons

General

The RediStart Micro II has a display/keypad that allows the user to set the starter parameters using a plain English interface. The functions of the display buttons are as follows.



- Press to enter the menu system.
- Press to abandon changes made to a parameter (before pressing the Enter key).
- Press to exit a sub-menu.
- Press to exit the menu system.



- Press to enter a menu.
- Press to enter a sub-menu.
- Press to change the parameter displayed.
- Press to store the new value entered.



- Select the menu to enter.
- Select the sub-menu to enter.
- Scroll between parameters when in a specific menu or sub-menu.
- Increase a parameter value.
- Press to view the meter pages when the main display is shown.



- Select the menu to enter.
- Select the sub-menu to enter.
- Scroll between parameters when in a specific menu or sub-menu.
- Decrease a parameter value.
- Press to view the meters when the main display is shown.



- Press to start the motor when the starter is connected for local display control.
- Press to activate the BIST (Built-In Self Test).
- If 2-wire control is used or the Start button is disabled, this button is inoperative.



- Press to stop the motor when the starter is connected for local display control.
- If 2-wire control is used or the Stop button is disabled, this button is inoperative.

5.1 PROGRAMMING: How To Program

Menu Structure

Menu Structure

The RediStart Micro II has a 2 level menu structure. There are eight main menus that contain parameters related to the different functions of the starter and five of the main menus contain additional sub-menus that divide the parameters into functional groups. The following shows the structure of the menu structure.

Main Menu

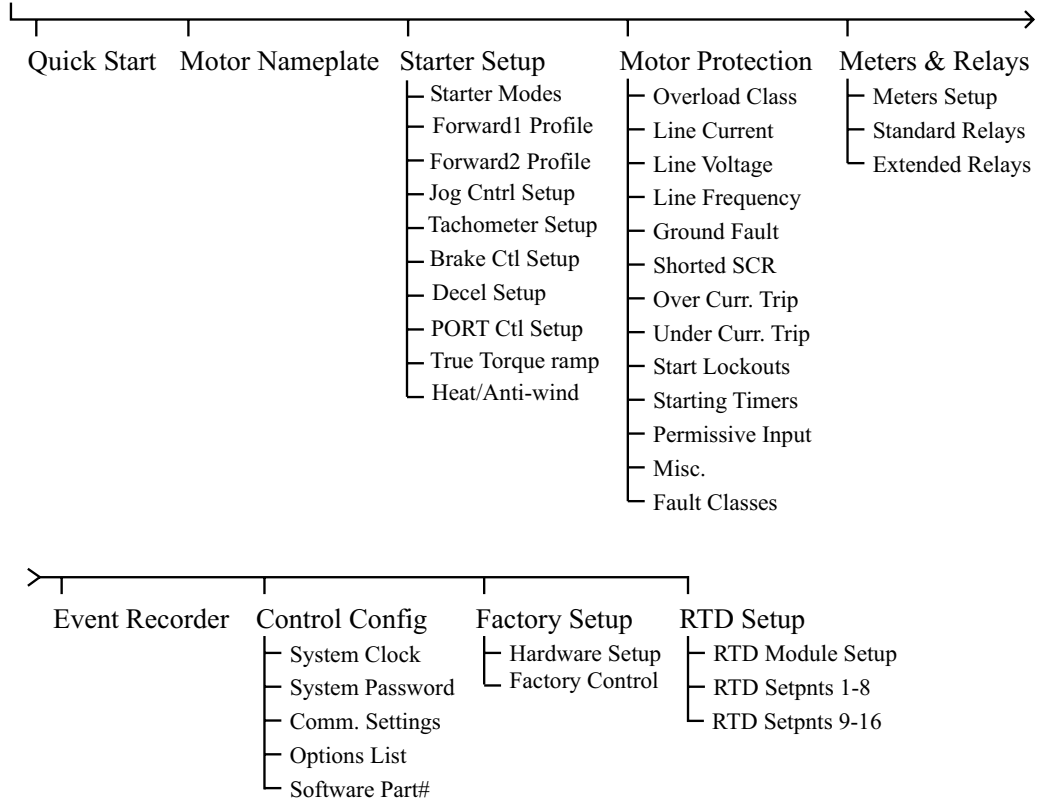

5.1 PROGRAMMING: How To Program

Viewing a Parameter

Viewing a Parameter

To access a specific parameter in the RediStart Micro II menu structure, follow these steps. Refer to the previous page for a graphical representation of the menu structure.

- Press the Menu button to enter the menu system.
- Press the Up or Down buttons to get the desired menu on the display.
- Press the Enter button to go into the menu.
- Press the Up or Down button to get to the desired sub-menu, if necessary.
- Press the Enter button to go into the sub-menu, if necessary.
- Press the Up or Down arrow buttons until the parameter is displayed.

Changing a Parameter

Changing a Parameter

To change a parameter, follow these steps;

- View the desired parameter by following the Viewing a Parameter instructions.
- Press the Enter button to switch to the change parameter screen.
- Press the Up or Down buttons to get the desired value on the screen.
- Press the Enter button to store the new value.

An Example

The ramp time is set to 30 seconds and it is to be changed to 20 seconds.

The following steps must be taken to change the ramp time.

- Press the Menu button to enter the menu system.
- Press the Down button twice to get to the Starter Setup screen.
- Press the Enter button to access the Starter Setup menu.
- Press the Down button once to display the Forward1 Profile.
- Press the Enter button to access the Forward1 Profile sub-menu.
- Press the Down button twice to display the Ramp Time parameter.
- Press the Enter button to allow a change to the ramp time.
- Press the Down button repeatedly to change the Ramp Time to the desired value.
- Press the Enter button to store the value.
- Press the Menu button repeatedly to return to the main display.

5.2 PROGRAMMING: Quick Start

Motor FLA

Parameter Description	<p>The motor FLA parameter must be set to the full load amps of the motor connected to the starter for the starter to function correctly. If there is more than one motor connected, the motor FLA should be set to the sum of the connected motor full load amps.</p> <p>NOTE: The starter uses the entered motor FLA for every current based calculation. If the motor FLA is not entered correctly, the current ramp profile and many of the starter's advanced protection features will not function properly.</p>
Parameter Values	The motor FLA parameter is adjustable from 1 to 1200 amps in 1 amp increments.
Parameter Default	The default value for the motor FLA is 1 amp.

Serv. Fact (service factor)

Description	<p>The service factor parameter should be set to the service factor of the motor. The service factor is used for the overload calculations. If the service factor of the motor is not known then the service factor should be set to 1.00. See the motor overload parameter on page 11 for a detailed description on how to set the service factor for different applications to avoid overload trips.</p>
Values	<p>The service factor can be set from 1.00 to 1.99, in 0.01 increments.</p> <p>NOTE: The NEC (National Electrical Code) does not allow the service factor to be set above 1.40. Check with other local electrical codes for their requirements.</p>
Default	The default value for the service factor is 1.15.

Start Mode

Description	<p>The Start Mode parameter allows for an optimal start of the motor based on the application. For a description of the possible Start Mode parameters, refer to page 33 in the Operations chapter.</p>
Values	The Start Mode Parameter can be set to Curr, TT, or Tach.
Default	The default value for the Start Mode is Curr.

Stop Mode

Description	<p>The Stop Mode parameter allows for the most suitable stop of the motor based on the application. For a description of the possible Stop Mode parameters, refer to page 33 in the Operations chapter.</p>
Values	The Stop Mode can be set to Coas, VDCL, TT, or Brak.
Default	The default value for the Stop Mode is Coas.

5.2 PROGRAMMING: Quick Start

Int. Curr. (initial current)

Description

The initial current parameter is set as a percentage of the motor FLA parameter setting. The initial current parameter sets the current that will initially reach the motor when a start is commanded.

If the motor does not rotate within a few seconds after a start command, the initial current should be increased. If the motor takes off too quickly after a start command, the initial current should be decreased.

The initial current must be set to a value that is lower than the maximum current parameter setting.

A typical setting for the initial current parameter is from 50% to 175%.

Values

The initial current is adjustable from 50% to 400% in 1% intervals.

Default

The default value for the initial current is 100%.

Max. Curr. (maximum current)

Description

The maximum current parameter is set as a percentage of the motor FLA parameter setting. The maximum current parameter performs two functions. It sets the current for the end of the ramp profile. It also sets the maximum current that is allowed to reach the motor while the motor is being started.

If the ramp time expires before the motor has reached full speed, the starter will hold the current at the maximum current level until the stall time expires, the motor reaches full speed, or the overload trips.

Typically, the maximum current is set to 600% unless the power system or load dictates the setting of a lower maximum current.

Values

The maximum current is adjustable from 100% to 600% in 1% intervals.

Default

The default value for the maximum current is 600%.

Ramp Time

Description

The ramp time sets the amount of time that it takes for the starter to linearly increase the current from the initial current level to the maximum current level.

A typical ramp time setting is from 15 to 30 seconds.

Settings

The ramp time is adjustable from 0 to 120 seconds in 1 second intervals.

Default

The default value for the ramp time is 15 seconds.

Overload

Description	<p>The overload parameter sets the class of the electronic overload. The starter stores the thermal overload value as a percentage value between 0 and 100%, with 0% representing a “cold” overload and 100% representing a tripped overload. See page 11 for the overload trip time vs current curves.</p> <p>When the overload is set to not available (OFF), the electronic overload is disabled and another motor overload protection device must be supplied.</p> <p>When the overload is set to bypass (BYP), the electronic overload is disabled during starting and then the thermal content is charged to 90% once the starter gets up-to-speed. When the motor is up-to-speed, the RediStart Micro II will use a class 10 overload for the motor protection.</p>
Values	<p>The overload can be set to;</p> <ul style="list-style-type: none">• OFF - no thermal overload• 1-40 - class 1 through 40 overload in steps of 1.• BYP - overload bypassed during starting, class 10 once up-to-speed
Default	<p>The default value for the overload parameter is 10.</p>

Phase Orde (Phase Order)

Description	<p>The line phasing parameter sets the phase sensitivity of the starter. This can be used to protect the motor from a possible change in the incoming phase sequence. If the incoming phase sequence does not match the set phase rotation, the starter will display phs err while stopped and will fault if a start is attempted.</p>
Values	<p>The line phasing can be set to;</p> <ul style="list-style-type: none">• Ins - will run with either phase sequence• ABC - will only run with ABC phase sequence• CBA - will only run with CBA phase sequence
Default	<p>The default value for the phase sensitivity parameter is Ins.</p>

5.3 PROGRAMMING: Motor Nameplate

Motor FLA

Description



The motor FLA parameter must be set to the full load amps of the motor connected to the starter for the starter to function correctly. If there is more than one motor connected, the motor FLA should be set to the sum of the connected motor full load amps.

NOTE: The starter uses the entered motor FLA for every current based calculation. If the motor FLA is not entered correctly, the current ramp profile and many of the starter's advanced protection features will not function properly.

Values

The motor FLA parameter is adjustable from 1 to 1200 amps in 1 amp increments.

Default

The default value for the motor FLA is 1 amp.

Serv. Fact (service factor)

Description

The service factor parameter should be set to the service factor of the motor. The service factor is used for the overload calculations. If the service factor of the motor is not known then the service factor should be set to 1.00. See the motor overload parameter on page 11 for a detailed description on how to set the service factor for different applications to avoid overload trips.

Values

The service factor can be set from 1.00 to 1.99, in 0.01 increments.

NOTE: The NEC (National Electrical Code) does not allow the service factor to be set above 1.40. Check with other local electrical codes for their requirements.

Default

The default value for the service factor is 1.15.

Motor RPMs

Description

The Motor RPMs can be set to match the RPM rating of the motor.

Values

The Motor RPMs can be set from 1 to 3600RPM's in increments of 1.

Default

The default value for the Motor RPMs is 1760.

Energy Sav (energy saver)

Description

The energy saver will lower the voltage applied to a lightly loaded motor. It will continue to lower the voltage until it finds the point where the current reaches its lowest level and then regulate the voltage around this point. If the load on the motor increases, the starter will immediately return the output of the starter to full voltage. Potential true saving are in the order of 1 kilowatt per 100 horsepower.

Values

The energy saver can be set to Off or On. If the starter is equipped with a bypass contactor then the energy saver will be fixed as Off.

Default

The default value for the energy saver is Off.

5.3 PROGRAMMING: Motor Nameplate

Source Volt (source voltage)

Description

The source voltage parameter sets the line voltage that is used when the starter performs high/low line voltage calculations. See the high/low voltage parameter on page 74 for a description of the over/under voltage parameter.

When the source voltage is set to Auto, the starter will pick a standard line voltage value, based on the average incoming line voltage, when a start is commanded. The operating voltage is selected as;

- 208VAC if average line voltage is between 180VAC and 224VAC.
- 240VAC if average line voltage is between 225VAC and 269VAC.
- 315VAC if average line voltage is between 270VAC and 334VAC.
- 380VAC if average line voltage is between 345VAC and 409VAC.
- 460VAC if average line voltage is between 410VAC and 489VAC.
- 480VAC if average line voltage is between 490VAC and 524VAC.
- 575VAC if average line voltage is between 525VAC and 650VAC.
- 1000VAC if average line voltage is between 651VAC and 1000VAC.

When the source voltage is set to a numerical value, the starter will use the entered value as the line voltage.

Values

The source voltage can be set to Auto or from 100 volts to 1000 volts, in 1 volt increments.

Default

The default value for the source voltage is Auto.

5.4 PROGRAMMING: Starter Setup - Starter Modes

Start Mode

Description	The Start Mode parameter allows for an optimal start of the motor based on the application. For a description of the possible Start Mode parameters, refer to page 33 in the Operations chapter.
Values	The Start Mode Parameter can be set to Curr, TT, or Tach.
Default	The default value for the Start Mode is Curr.

Stop Mode

Description	The Stop Mode parameter allows for the most suitable stop of the motor based on the application. For a description of the possible Stop Mode parameters, refer to page 33 in the Operations chapter.
Values	The Stop Mode can be set to Coas, VDCL, TT, or Brak.
Default	The default value for the Stop Mode is Coas.

5.5 PROGRAMMING: Starter Setup - Forward1 Profile

Int. Curr. (initial current)

Description

The initial current parameter is set as a percentage of the motor FLA parameter setting. The initial current parameter sets the current that will initially reach the motor when a start is commanded.

If the motor does not rotate within a few seconds after a start command, the initial current should be increased. If the motor takes off too quickly after a start command, the initial current should be decreased.

The initial current must be set to a value that is lower than the maximum current parameter setting.

A typical setting for the initial current parameter is from 50% to 175%.

Values

The initial current is adjustable from 50% to 400% in 1% intervals.

Default

The default value for the initial current is 100%.

Max. Curr. (maximum current)

Description

The maximum current parameter is set as a percentage of the motor FLA parameter setting. The maximum current parameter performs two functions. It sets the current for the end of the ramp profile. It also sets the maximum current that is allowed to reach the motor while the motor is being started.

If the ramp time expires before the motor has reached full speed, the starter will hold the current at the maximum current level until the stall time expires, the motor reaches full speed, or the overload trips.

Typically, the maximum current is set to 600% unless the power system or load dictates the setting of a lower maximum current.

Values

The maximum current is adjustable from 100% to 600% in 1% intervals.

Default

The default value for the maximum current is 600%.

Ramp Time

Description

The ramp time sets the amount of time that it takes for the starter to linearly increase the current from the initial current level to the maximum current level.

A typical ramp time setting is from 15 to 30 seconds.

Settings

The ramp time is adjustable from 0 to 120 seconds in 1 second intervals.

Default

The default value for the ramp time is 15 seconds.

5.5 PROGRAMMING: Starter Setup - Forward1 Profile

Kick Curr. (kick current)

Description	The kick current parameter is set as a percentage of the motor FLA parameter setting. The kick current sets a current level that overrides the current ramp profile, for the set kick time, when a start is commanded. If a kick time is programmed, the starter will provide the current level specified by the kick current setting for this set time. This current can be used to overcome the break over torque of some loads, while still allowing the starter to smoothly accelerate the load to full speed.
Values	The kick current is adjustable from 100% to 600% in 1% increments.
Default	The default value for the kick current is 300%.

Kick Time

Description	<p>The kick time parameter sets the amount of time that the kick current level is provided to the motor when a start is commanded.</p> <p>If the kick time is set to any time other than Off, the starter will provide the kick current level for the set time. The kick time should be increased or decreased to reach the time required to begin rotating the load.</p>
Values	The kick time is adjustable from 0.1 to 10.0 seconds in 0.1 second intervals. If a kick current is not required, the kick time should be set to Off.
Default	The default value for the kick time is Off.

5.6 PROGRAMMING: Starter Setup - Forward2 Profile

Forward #2 Ramp Profile

General The forward #2 ramp profile sub-menu contains the parameters that set the starting ramp profile when the second ramp is selected. The second ramp is selected by applying 120VAC to input 9 of the JC13 terminal block on the RediStart Micro II CPU card.

Int. Curr. (initial current)

Description The initial current parameter is set as a percentage of the motor FLA parameter setting. The initial current parameter sets the current that will initially reach the motor when a start is commanded.

If the motor does not rotate within a few seconds after a start command, the initial current should be increased. If the motor takes off too quickly after a start command, the initial current should be decreased.

The initial current must be set to a value that is lower than the maximum current parameter setting.

A typical setting for the initial current parameter is from 50% to 175%.

Values The initial current is adjustable from 50% to 400% in 1% intervals.

Default The default value for the initial current is 100%.

Max. Curr. (maximum current)

Description The maximum current parameter is set as a percentage of the motor FLA parameter setting. The maximum current parameter performs two functions. It sets the current for the end of the ramp profile. It also sets the maximum current that is allowed to reach the motor while the motor is being started.

If the ramp time expires before the motor has reached full speed, the starter will hold the current at the maximum current level until the stall time expires, the motor reaches full speed, or the overload trips.

Typically, the maximum current is set to 600% unless the power system or load dictates the setting of a lower maximum current.

Values The maximum current is adjustable from 100% to 600% in 1% intervals.

Default The default value for the maximum current is 600%.

Ramp Time

Description The ramp time sets the amount of time that it takes for the starter to linearly increase the current from the initial current level to the maximum current level.

A typical ramp time setting is from 15 to 30 seconds.

Settings The ramp time is adjustable from 0 to 120 seconds in 1 second intervals.

Default The default value for the ramp time is 15 seconds.

5.6 PROGRAMMING: Starter Setup - Forward2 Profile

Kick Curr. (kick current)

Description	The kick current parameter is set as a percentage of the motor FLA parameter setting. The kick current sets a current level that overrides the current ramp profile, for the set kick time, when a start is commanded. If a kick time is programmed, the starter will provide the current level specified by the kick current setting for this set time. This current can be used to overcome the break over torque of some loads, while still allowing the starter to smoothly accelerate the load to full speed.
Values	The kick current is adjustable from 100% to 600% in 1% increments.
Default	The default value for the kick current is 300%.

Kick Time

Description	<p>The kick time parameter sets the amount of time that the kick current level is provided to the motor when a start is commanded.</p> <p>If the kick time is set to any time other than Off, the starter will provide the kick current level for the set time. The kick time should be increased or decreased to reach the time required to begin rotating the load.</p>
Values	The kick time is adjustable from 0.1 to 10.0 seconds in 0.1 second intervals. If a kick current is not required, the kick time should be set to Off.
Default	The default value for the kick time is Off.

5.7 PROGRAMMING: Starter Setup - Jog Cntrl Setup

Jog Curr. (jog current)

Description

The jog current parameter is set as a percentage of the motor FLA parameter setting. The jog current parameter is used to set the maximum current that will reach the motor while the motor is being operated in the jog at set speed mode. It should be set to the lowest possible current level that will still operate the motor.



When a motor is operating in the jog at set speed mode, its cooling capability is greatly reduced. Therefore, the running time of the motor is dependant on the motor current. If the jog at set speed will be used on a regular basis, the motor temperature should be monitored using a thermostat. The thermostat can be connected between the power and input terminal 1 of the JC13 terminal block on the RediStart Micro II computer card so that the starter will trip when a fault occurs. Alternatively, temperature monitoring devices, such as thermistors or RTDs can be used. This will prevent the motor from being overheated and inadvertently damaged.

Due to the way the jog at set speed operates, the starter may require the installation of a 5% line reactor to eliminate harmonic problems being introduced into the power system. This is dependent on the size of the motor in relation to the capacity of the power system. The jog at set speed has more of an effect on a weak power system.

Values

The jog current is adjustable from 25% to 250% in 1% increments.

Default

The default value for the jog current is 50%.

Max. Time (maximum time)

Description

The maximum time parameter sets the time limit for continuous operation in the jog at set speed mode. This parameter should be set to a value that doesn't allow the motor to be operated in the jog at set speed mode for such a length of time that damage to the motor can occur.



During initial set-up, monitor the motor temperature to determine it's maximum safe jogging time and then enter this time. This can help avoid damage to the motor by stopping the starter before the motor overheats. This parameter does not stop the operator from stopping and re-starting the motor during jog operation which could still lead to the operation time of the motor being exceeded. Use the timers in the Starts Lockouts submenu to protect against this.

Values

The maximum time is adjustable from 1 to 9000 seconds in 1 second intervals.

Default

The default value for the maximum time parameter is 200 seconds.

5.7 PROGRAMMING: Starter Setup - Jog Cntrl Setup

Kick Curr (kick current)

Description

The kick current parameter sets the level of the kick current that is applied to the motor when a start command is given and the starter is set for operation in the forward jog at set speed mode.

This parameter should be set to a midrange value and then the kick time should be increased in 0.1 second intervals until the kick is applied long enough to start the motor rotating when a start is given. If the motor does not start rotating with the set kick current value then increase the kick current and begin adjusting the kick time from 0.1 seconds again.

If the motor accelerates to a speed which is greater than the jog speed, then either the kick current or kick time should be decreased.

Values

The kick current parameter is adjustable from 50% to 400% in 1% increments.

Default

The default value for the kick current parameter is 300%.

Kick Time

Description

The kick time parameter sets the length of time that the current level, as specified by the kick current, is applied to the motor.

Values

The kick time parameter is adjustable from 0.1 to 10.0 seconds in 0.1 second intervals. The kick time parameter can also be set to Off.

Default

The default value for the kick time is Off.

FWD Speed

Description

The forward speed parameter sets the frequency of the cyclically converted signal that reaches the motor while the starter is operating in the forward direction and the forward jog at set speed mode is selected. This is done by applying 120VAC to input terminal 4 of the JC13 terminal block on the RediStart Micro II computer card.

Values

The forward speed can be set to 7% or 14%.

Default

The default value for the forward speed is 14%.

5.8 PROGRAMMING: Starter Setup - Tachometer Setup

FS Volts (Full Speed Volts)

Description	<p>The FS Volts parameter sets the tachometer input voltage at full speed. This value should be set at full (unloaded) motor speed.</p> <p>For example: A tachometer rated at 0.0033 volts-per-rpm is mounted on a 4-pole 1800 rpm motor. Therefore, the FS Volts should be set to: $0.0033 \times 1800 = 5.94$ volts.</p>
Values	The tachometer FS Volts value can be set between 1.00 and 7.00 volts in 0.01 volt increments.
Default	The default value for the tachometer FS Volts value is 5.00 volts.

Stab Cnst (Stability Constant)

Description	<p>The Stab Cnst parameter is used to control the speed and bandwidth of the of the speed controller.</p> <p>NOTE: Lower values slow down the controller's response, which is useful if the system has a large inertia and/or low stiffness. Higher values will speed up the controller's response, which can be useful if the more precise speed control is necessary. If the stability constant is set too low, the starter will not track the speed reference properly and the motor speed profile will not be linear.</p>
Values	The Stab Cnst parameter is adjustable from 10% to 150% in 1% increments.
Default	The default value for the Stab Cnst parameter is 100%.

Ramp#1 Tim

Description	The Ramp#1 Tim parameter sets the length of time that the D.C. brake current is applied to the motor.
Values	The Ramp#1 Tim is adjustable from 0 to 120 seconds in 1 second intervals.
Default	The default value for the Ramp#1 Tim is 15 seconds.

Ramp#2 Tim

Description	The Ramp#2 Tim parameter sets the length of time that the D.C. brake current is applied to the motor.
Values	The Ramp#2 Tim is adjustable from 0 to 120 seconds in 1 second intervals.
Default	The default value for the Ramp#2 Tim is 15 seconds.

5.8 PROGRAMMING: Starter Setup - Tachometer Setup

TLoss Dela (Tachometer Signal Loss Delay)

Description	<p>The TLoss Delay time is the allowable time the starter will operate when a tachometer signal is lost. If the signal is lost, the starter will perform the action set by the TLoss Mode parameter.</p> <p>NOTE: Nuisance tachometer loss faults at start can be prevented by setting the initial current parameter to a value that allows the motor to begin rotating soon after a start is commanded.</p>
Values	<p>The TLoss Delay time parameter is adjustable from 0.1 seconds to 90.0 seconds in 0.1 second intervals.</p>
Default	<p>The default value for the TLoss Delay time is 1.5 seconds.</p>

TLoss Mode (Tachometer Signal Loss Mode)

Description	<p>The TLoss Mode determines the starter's action if it has been detected the tachometer signal is lost.</p> <p>NOTE: If Current ramp or TruTorque ramp is selected, all values within these ramp profiles must be set for proper operation.</p> <p>NOTE: If Current ramp or TruTorque ramp is selected, and the tachometer signal is lost, the starter will shut down and automatically restart with the new starting mode. The new start mode will apply until a manual reset to Tach is performed.</p>
Values	<p>The TLoss Mode parameter can be set to Shut (shutdown), Curr (Current Ramp), or TT (TruTorque Ramp).</p>
Default	<p>The default value for the TLoss Mode is Shut.</p>

5.9 PROGRAMMING: Starter Setup - Brake Ctl Setup

D.C. Injection Braking

Description The D.C. injection braking parameter is used to quickly bring a motor to a stop. The D.C. braking applies a static D.C. field to the stator of the motor which applies a braking torque to the rotor which makes it stop much in the same way the 3 phase rotating magnetic field brings the motor up to operating speed.

Braking Options There are three (3) levels of D.C. braking current rated as a percentage of the motor FLA value that are available depending on the type of starter. They are:

- Light duty - 100% D.C. Current for 30 seconds.
- Standard Duty - 300% D.C. current for 30 seconds (RSM7 or RSM11).
- Heavy Duty - 300% D.C. current for 90 seconds (RSM7 or RSM11).



NOTE: When DC injection braking is used on a motor, discretion must be used when setting up the DC braking parameters. Excessive motor heating may result if the load inertia is large or the brake current or brake time is set too high. In Heavy-Duty brake applications, caution must be used to assure the motor has the thermal capacity to brake the desired load, in the desired period of time, without excessive heating.

Current #1

Description The brake #1 current parameter sets the level of D.C. current applied to the motor. If the motor braking is too fast, the current should be reduced. If the motor is not braking fast enough, the current level should be increased. To minimize motor heating, only the necessary level of current should be used.

Values The brake #1 current is adjustable from 10% to 100% of available brake current in 1% increments.

Default The default value for the brake #1 current is 25%.

Time #1

Description The brake #1 time parameter sets the length of time that the D.C. brake current is applied to the motor. If the motor is still rotating faster than desired at the end of the brake time, increase the brake time if possible. If the motor stops before the desired brake time has expired, decrease the brake time to minimize motor heating.

Values The brake #1 time parameter is adjustable from 0 to 30 seconds (0 to 90 seconds for heavy duty) in 1 second intervals.

Default The default value for the brake #1 time is 0 seconds.

Current #2

Description The brake #2 current parameter sets the level of the D.C. current applied to the motor when the second ramp profile is selected. If the motor braking is too fast, the current should be reduced. If the motor is not braking fast enough, the current level should be increased. To minimize motor heating, only the necessary level of current should be used.

Values The brake #2 current is adjustable from 10% to 100% of available brake current in 1% increments.

Default The default value for the brake #2 current is 25%.

5.9 PROGRAMMING: Starter Setup - Brake Ctl Setup

Time #2

Description

The brake #2 time parameter sets the length of time that the D.C. brake current is applied to the motor when the second ramp is selected. If the motor is still rotating faster than desired at the end of the brake time, increase the brake time if possible. If the motor stops before the desired brake time has expired, decrease the brake time to minimize motor heating.

Values

The brake #2 time parameter is adjustable from 0 to 30 seconds (0 to 90 seconds for heavy duty) in 1 second intervals.

Default

The default value for the brake #2 time parameter is 0 seconds.

5.10 PROGRAMMING: Starter Setup - Decel Setup

V Level #1

Description	<p>The decel level #1 parameter sets the starting voltage for the voltage ramp deceleration ramp profile.</p> <p>The deceleration profile uses an open loop voltage ramp profile. The decel level #1 parameter sets the starting point on the S curve. This means that decel level #1 is not set as a percentage of actual line voltage.</p> <p>If the motor initially surges when a stop is commanded, decrease this parameter value. If there is a sudden drop in motor speed when a stop is commanded, increase this parameter value.</p> <p>A typical decel level #1 setting is between 30% and 40%.</p>
Values	<p>The decel level #1 is adjustable from 10% to 100% in 1% increments. The decel level #1 setting must be greater than the decel level #2 setting.</p>
Default	<p>The default value for the decel level #1 parameter is 40%.</p>

V Level #2

Description	<p>The decel level #2 parameter sets the ending voltage for the voltage ramp profile. Decel level #2 can not be set greater than decel level #1.</p> <p>The deceleration profile uses an open loop voltage ramp profile. The decel level #2 parameter sets the ending point on the S curve. This means that decel level #2 is not set as a percentage of actual line voltage.</p> <p>If the motor stops rotating before the deceleration time has expired, increase this parameter value. If the motor is still rotating when the deceleration time has expired, decrease this parameter value. A typical decel level #2 setting is between 10% and 20%.</p>
Values	<p>The decel level #2 parameter is adjustable from 1% to 99% in 1% increments. The decel level #2 must be less than the decel level 1 setting.</p>
Default	<p>The default value for the decel level #2 parameter is 20%.</p>

V DCL Time (decel time)

Description	<p>The decel time parameter sets the amount of time taken to go from the decel level #1 setting to the decel level #2 setting.</p> <p>If the motor stops rotating before the decel time has expired, decrease the decel time. If the motor is still rotating when the decel time expires, increase the decel time.</p> <p>A typical decel time setting is 20 to 40 seconds.</p>
Values	<p>The decel time parameter is adjustable from 0 to 60 seconds in 1 second intervals.</p>
Default	<p>The default value for the decel time parameter is 0 seconds.</p>

5.10 PROGRAMMING: Starter Setup - Decel Setup

TT DCL Tim (TruTorque deceleration time)

Description	The TruTorque deceleration time sets how quickly the motor decelerates. Usually a time of 30 seconds is a good starting point. To make the motor decelerate at a slower rate increase this time or to make the motor stop quicker decrease this time.
Values	The TruTorque deceleration time parameter is adjustable from 0 to 100 seconds in 1 second intervals.
Default	The default TruTorque deceleration time is 0 seconds.

TT DCL Tor (ending deceleration torque)

Description	<p>The value sets the final torque level for the Trutorque deceleration ramp. In most cases, this parameter can be set to 10%.</p> <p>To adjust this parameter, it is necessary to observe the motor. If the motor is coming to a stop too quickly or if the starter continues to apply current to the motor after the motor has stopped this parameter can be increased in 5% increments.</p> <p>If the motor is still rotating when the desired deceleration time has expired, decrease this parameter by 5% and retest.</p>
Values	The TruTorque deceleration ending torque value can be set from 1% to 100% torque in 1% steps.
Default	The default TruTorque deceleration ending torque setting is 10%

5.11 PROGRAMMING: Starter Setup - PORT CTL Setup

Fault Dly (Fault Delay)

Description	The Fault Dly parameter determines how long a power disturbance can exist before the micro system will fault out on a power loss; and no longer restart. If the Fault Dly parameter is set to OFF, the PORT detection will be disabled and the standard motor protection features will be enabled.
Values	The Fault Dly parameter is adjustable from OFF, 0.1 through 90.0 seconds, in 0.1 second increments.
Default	The default value for the Fault Dly parameter is OFF.

Bypass Dly (Bypass Delay)

Description	The Bypass Dly parameter determines when the bypass contactor will drop after a power disturbance is sensed.
Values	The Bypass Dly parameter is adjustable from 0.0 through 3.0 seconds, in 0.1 second increments.
Default	The default value for the Bypass Dly time is 0.0 seconds.

Sense Time

Description	The Sense Time parameter determines how long a power outage must exist before the micro will drop to a coast to stop, and wait for a valid line voltage before restarting.
Values	The Sense Time parameter is adjustable from 0.01 through 0.50 seconds, in 0.01 increments.
Default	The default value for the Sense Time parameter is 0.05 seconds.

5.12 PROGRAMMING: Starter Setup - TruTorque Ramp

Int Torque (initial torque)

Description	The initial torque parameter sets the initial torque level that the motor will produce during starting. This parameter should be set to a level that allows the motor to begin acceleration with a few seconds of a start command being received.
Values	The initial torque is adjustable from 1% to 100% in 1% increments.
Default	The default value for initial torque is 20%.

Max Torque (maximum torque)

Description	The maximum torque parameter sets the final level of torque that is supplied to the motor during starting. For a loaded motor, the maximum torque parameter initially should be set to 100% or greater. If the maximum torque value is set too low, the motor may not produce enough torque to reach full speed (UTS). On a lightly loaded motor this parameter may be reduced below 100% to provide for smoother starts.
Values	The maximum torque is adjustable from 10% to 325% in 1% increments.
Default	The default value for the maximum torque parameter is 105%.

Ramp Time

Description	<p>The ramp time parameter sets the time it takes for the commanded torque to go from the Initial Torque Setting to the Maximum Torque Setting. To make the motor accelerate faster, decrease the ramp time. To make the motor accelerate slower, increase the ramp time.</p> <p>If the ramp time expires before the motor reaches full speed the starter will maintain the set Maximum Torque level until either the motor reaches full speed, the stall (UTS) timer expires, or the motor thermal overload trips.</p> <p>Note: This ramp time setting is only used for TruTorque starts. It is not the same ramp time parameter that is used for current ramp profile starts.</p> <p>Note: Setting the ramp time to a specific value does not necessarily mean that the motor will take this time to accelerate to full speed. The motor and load may achieve full speed before the ramp time expires if the application does not require the set ramp time and maximum torque to reach full speed. Alternatively, the motor and load may take longer than the set ramp time to achieve full speed.</p>
Values	The TruTorque ramp time is adjustable from 0 to 120 seconds in 1 second intervals.
Default	The default value for the TruTorque ramp time is 15 seconds.

5.12 PROGRAMMING: Starter Setup - TruTorque Ramp

TT Over Cu (TruTorque overcurrent trip)

Description	<p>The TruTorque overcurrent trip parameter is set as a percentage of FLA. If the motor current remains above this level for longer than the delay time the starter will trip. In order to protect applications such as pumps from water hammer when a fault does occur a normal deceleration profile will occur to "gracefully" shut down the system before the TruTorque Overcurrent Fault is displayed and the starter is disabled.</p> <p>Note: The TruTorque Overcurrent Trip only operates during TruTorque ramping before the starter has indicated an up-to-speed condition. If overcurrent protection is desired after the motor has come up to speed the Over Current parameter under the Motor Protection menu must be used.</p>
Values	The TruTorque overcurrent can be set to Off or from 100% to 800% of FLA in 1% increments.
Default	The default value for the TruTorque Overcurrent parameter is Off

Ovr Cur DI (TruTorque overcurrent trip delay)

Description	The TruTorque overcurrent trip delay parameter sets the time that the motor current must exceed the TruTorque Overcurrent Trip setting, while the starter is ramping, before a trip will occur.
Values	The TruTorque overcurrent delay parameter can be set from 0.1 to 90.0 seconds in 0.1 second intervals.
Default	The default value for the TruTorque overcurrent delay parameter is 0.1 seconds.

5.13 PROGRAMMING: Starter Setup - Heat/Anti-wind

Heat Curr. (heater current)

Description

The heater current parameter sets the level of D.C. current that reaches the motor when the motor winding heater/anti-windmilling brake is enabled.

The motor winding heater/anti-windmilling brake can be used to heat a motor to prevent internal condensation or it can be used to prevent a motor from rotating.



NOTE: The motor can still slowly creep when the anti-windmilling brake is being used. If the motor has to be held without rotating, a mechanical means of holding the motor has to be used.

The motor winding heater/anti-windmilling brake operation has to be enabled by placing a jumper between terminals 4 and 13 of JC11.

To use the motor winding heater/anti-windmilling brake, apply 120VAC to input terminal 8 of the JC13 terminal block on the RediStart Micro II computer card and then give the unit a start command. Instead of starting the motor, the unit will provide a continuous, low level D.C. current to the motor.



The level of DC current applied to the motor during this operation needs to be monitored to ensure that the motor isn't overheated. The current level should be set as low as possible and then slowly increased over a long period of time. While this is being done, the temperature of the motor should be monitored to ensure it is not overheating.

Values

The heater current can be set from 5% to 25% in 1% increments.

Default

The default value for the heater current is 10%.

5.14 PROGRAMMING: Motor Protection - Overload

Overload

Description

The overload parameter sets the class of the electronic overload. The starter stores the thermal overload value as a percentage value between 0 and 100%, with 0% representing a “cold” overload and 100% representing a tripped overload. See page 11 for the overload trip time vs current curves.

When the overload is set to not available (OFF), the electronic overload is disabled and another motor overload protection device must be supplied.

When the overload is set to bypass (BYP), the electronic overload is disabled during starting and then the thermal content is charged to 90% once the starter gets up-to-speed. When the motor is up-to-speed, the RediStart Micro II will use a class 10 overload for the motor protection.

Values

The overload can be set to;

- OFF - no thermal overload
- 1-40 - class 1 through 40 overload
- BYP - overload bypassed during starting, class 10 once up-to-speed

Default

The default value for the overload parameter is 10.

5.15 PROGRAMMING: Motor Protection - Line Current

% Imbalanc (percent imbalance)

Description	<p>The percent imbalance parameter sets the allowable phase to average current difference that is allowed before the starter will shut down. The current imbalance must exist for the amount of time set by the imbalance delay time before this will occur.</p> <p>The current imbalance for each phase is calculated as the percentage difference between the phase current and the average current. The equation for the current imbalance is;</p> $\% \text{ imbalance} = \frac{I_{ave} - I_{phase}}{I_{ave}} \times 100\%$ <p>If the highest calculated current imbalance is greater than the current imbalance level, the starter will shut down the motor and display a fault 23 to fault 28 depending on the phase that has the out of range current.</p>
Values	The percent imbalance is adjustable from 10 to 40% in 1% increments.
Default	The default value for the percent imbalance is 15%.

Imbal Dela (imbalance delay)

Description	The imbalance delay parameter sets the time that the current imbalance must be greater than the percent imbalance parameter before a trip will occur.
Values	The imbalance delay parameter can be set from 0.1 to 90.0 seconds in 0.1 second intervals.
Default	The default value for the imbalance delay parameter is 0.5 seconds.

@ Stop Dly (current at stop delay)

Description	The current at stop delay parameter sets the time that a phase current must be greater than 5% of the motor FLA parameter, while the starter is in a stopped state, before a trip will occur.
Values	The current at stop delay parameter can be set from 0.1 to 10.0 seconds in 0.1 second intervals
Default	The default value for the current at stop delay parameter is 1.5 seconds.

5.15 PROGRAMMING: Motor Protection - Line Current

% No C@Run (percent no current at run)

Description	The percent no current at run parameter sets a low current operating level. If the current falls below this level, the RediStart Micro II will shut down the starter and give a no current at run fault. This level is set as a percentage of the motor full load amps. The current must remain below this parameter setting for the no current at run delay time before a fault will occur.
Values	The percent no current at run parameter can be set from 2 to 40% in 1% increments.
Default	The default value for the percent no current at run parameter is 5%.

No C@R Dly (no current at run delay)

Description	The no current at run delay parameter sets the time that the motor current must be less than the percent no current at run parameter setting, while the starter is in a run state, before a trip will occur.
Values	The no current at run parameter can be set from 0.1 to 90.0 seconds in 0.1 second intervals.
Default	The default value for the no current at run parameter is 1.0 seconds.

5.16 PROGRAMMING: Motor Protection - Line Voltage

H/L Volts (high/low voltage)

Description

The high/low voltage trip sets the allowable operating voltage range. If the voltage on any line goes outside of the allowable operating range, the starter will shut down and give a high or low line fault.

The low and high voltage trip points are calculated as follows;

$$V_{\text{low}} = V_{\text{base}} - V_{\text{base}} \times (\text{Parameter} \div 100)$$

$$V_{\text{high}} = V_{\text{base}} + V_{\text{base}} \times (\text{Parameter} \div 100)$$

The base voltage (V_{base}) that is used for the calculations is either set by the source voltage parameter (see page 53) or automatically selected according to the following list;

208VAC if average line voltage is between 180VAC and 224VAC.

240VAC if average line voltage is between 225VAC and 269VAC.

315VAC if average line voltage is between 270VAC and 334VAC.

380VAC if average line voltage is between 345VAC and 409VAC.

460VAC if average line voltage is between 410VAC and 489VAC.

480VAC if average line voltage is between 490VAC and 524VAC.

575VAC if average line voltage is between 525VAC and 650VAC.

1000VAC if average line voltage is between 651VAC and 1000VAC.

The base voltage (V_{base}) used for the calculations is selected by setting jumpers JPC17 and JPC18 on the RediStart Micro computer card. Refer to the jumper settings on page for information on setting these parameters.

The line voltage must be out of the specified range for the time specified by the delay time parameter before the starter will trip.

Values

The high/low voltage is adjustable from 10 to 30% in 1% increments.

Default

The default value for the high/low voltage parameter is 20%.

Delay Time

Description

The delay time parameter sets the time that the line voltage must go outside of the voltage range set by the high/low voltage parameter before a high or low voltage trip will occur.

This parameter may be lengthened to allow for temporary voltage fluctuations outside of the allowable voltage range. If the time is extended, the control voltage must be monitored to ensure it remains within acceptable limits. If the control voltage is fluctuating, an un-interruptible power supply should be used.

Values

The voltage delay parameter is adjustable from 0.1 to 90.0 seconds in 0.1 second intervals.

Default

The default value for the voltage delay parameter is 0.5 seconds.

PH Dect DI (Phase detect delay)

Description

The phase detect delay parameter sets the delay time on Fault #56: "Phase Detection." This fault detects a loss of proper phase timing even when the phase code remains valid; example: loss of line when the motor back generates a voltage. This allows a much faster detection than low line or no current at run faults.

Values

The PH Dect DI parameter is adjustable from 0.3 to 5.0 seconds in 0.1 second intervals.

Default

The default value for the PH Dect DI parameter is 0.8 seconds.

5.17 PROGRAMMING: Motor Protection - Line Frequency

High Freq. (high frequency)

Description	<p>The high frequency parameter sets the highest line frequency that the starter will operate on.</p> <p>When operating on line power, the default setting will usually suffice. If the application is speed sensitive, or the line power is suspect, the high frequency parameter can be set to the highest acceptable frequency. When operating on generator power, the high frequency parameter should be set to the highest acceptable frequency. This will ensure that a generator problem will not cause unnecessarily large fluctuations in the speed of the motor.</p> <p>The frequency must be above the high frequency setting for the frequency delay parameter before the starter will recognize a high frequency condition. Once a high frequency condition exists, the starter will shut down and display a fault 4, High Freq. Trip.</p>
Values	The high frequency trip is adjustable from 72 to 24hz in 1hz increments.
Default	The default value for the high frequency trip parameter is 72hz.

Low Freq. (low frequency)

Description	<p>The low frequency parameter sets the lowest line frequency that the starter will operate on.</p> <p>When operating on line power, the default setting will usually suffice. If the application is speed sensitive, or the line power is suspect, the low frequency parameter can be set to the lowest acceptable frequency. When operating on generator power, the low frequency parameter should be set to the lowest acceptable frequency. This will ensure that a generator problem will not cause unnecessarily large fluctuations in the speed of the motor.</p> <p>The frequency must be below the low frequency setting for the frequency delay parameter before the starter will recognize a low frequency condition. Once a low frequency condition exists, the starter will shut down and display a fault 5, frequency < Low Freq. Trip.</p>
Values	The low frequency trip is adjustable from 23 to 71hz in 1 Hz intervals.
Default	The default value for the low frequency trip parameter is 23hz.

Freq Delay (frequency delay)

Description	The frequency delay parameter sets the time that the line frequency must go above the high frequency trip point or below the low frequency trip parameter before a high or low frequency fault will occur.
Values	The frequency delay parameter can be set from 0.1 to 90.0 seconds in 0.1 second intervals.
Default	The default value for the frequency delay parameter is 0.1 seconds.

5.18 PROGRAMMING: Motor Protection - Ground Fault

GND Fault (ground fault)

Description	<p>The ground fault parameter sets a ground fault current trip or indicate level that can be used to protect the system from a ground fault condition.</p> <p>The starter monitors the instantaneous sum of the three line currents to detect the ground fault current. This is often referred to as residual ground fault protection. This type of protection is meant to provide machine ground fault protection only. It is not meant to provide human ground fault protection.</p> <p>The ground fault current has to remain above the ground fault level for the ground delay parameter time before the starter will recognize a ground fault condition. Once the starter recognizes a ground fault condition, it will shut down the motor and display a fault 71-Ground Fault. If a programmable relay is set to ground fault (GND), the starter will energize the relay when the condition exists.</p> <p>If it is desired to have the starter continue to operate after a ground fault is detected, enter the fault classes menu (see page 84) and change the classification of fault 71 to either Dis, WrnA, WrnB, or WrnC.</p> <p>A typical value for the ground fault current setting is 10% to 20% of the full load amps of the motor.</p>
Values	<p>The ground fault is adjustable from 1 to 100 amps in 1 amp increments. The ground fault current can also be set to Off by setting it below 1 amp.</p>
Default	<p>The default value for the ground fault parameter is Off.</p>

GND Delay (ground delay)

Description	<p>The ground delay parameter sets the period of time that the ground fault current must be above the ground fault current setting before a ground fault trip will occur.</p>
Values	<p>The ground delay parameter can be set from 0.1 to 90.0 seconds in 0.1 second intervals.</p>
Default	<p>The default value for the ground delay parameter is 1.0 seconds.</p>

5.19 PROGRAMMING: Motor Protection - Shorted SCR

@ Ramp DLY (shorted SCR at ramp delay)

Description	The shorted SCR at ramp parameter sets the period of time that there must be a current imbalance of more than 50%, while the starter is accelerating, before a shorted SCR fault occurs.
Values	The shorted SCR at ramp parameter can be set from 0.1 to 90.0 seconds in 0.1 second intervals.
Default	The default value for the shorted SCR at ramp parameter is 0.2 seconds.

@ Stop DLY (shorted SCR at stop delay)

Description	The shorted SCR at stop parameter sets the period of time that there must be a current flow of more than 50% of the motor FLA value, while the motor is stopped, before a shorted SCR fault will occur.
Values	The shorted SCR at stop parameter can be set from 0.1 to 90.0 seconds in 0.1 second intervals.
Default	The default value for the shorted SCR at stop parameter is 1.0 seconds.

5.20 PROGRAMMING: Motor Protection - Over Current

Current

Description	<p>The current parameter is set as a percentage of the motor FLA parameter. It sets a high current trip or indicate level that can be used to protect the system from an overloaded condition.</p> <p>The motor current has to remain above the current setting for the delay time parameter before the starter will recognize an over current condition.</p> <p>NOTE: The overcurrent parameter does not become active until after the starter has reached full speed.</p>
Values	<p>The current is adjustable from 50 to 800%, in 1% increments. The current can also be set to Off by going above 800%.</p>
Default	<p>The default value for the current parameter is Off.</p>

Detect Dly (detect delay)

Description	<p>The detect delay time parameter sets the period of time that the motor current must be greater than the over current level before a shear pin trip will occur.</p>
Values	<p>The detect delay time can be set from 0.1 to 90.0 seconds in 0.1 second intervals.</p>
Default	<p>The default value for the detect delay time parameter is 0.1 second.</p>

Release DI (release delay)

General	<p>The release delay time sets how long the relay is energized after the over current condition is cleared. This parameter is only functional if a relay has been programmed to OCT (over current trip) in the relay sub-menu (see page 87) and the fault has been disabled in the fault classes sub-menu (see page 84).</p>
Values	<p>The release delay time parameter can be set from 1.0 to 90.0 seconds in 0.1 second intervals</p>
Default	<p>The default value for the release delay time parameter is 10.0 seconds.</p>

5.21 PROGRAMMING: Motor Protection - Under Current

Current

Description	<p>The current parameter is set as a percentage of the motor FLA parameter. It sets a low current trip or indicate level and can be used to protect the system from an unloaded condition. The under current protection is especially useful to protect a pump. The motor current will fall when the pump becomes unloaded and the under current protection can be used to shut down the motor or warn of this unloaded condition.</p> <p>The motor current has to remain below the under current setting for the under current delay time parameter before the starter will recognize an under current condition.</p>
Values	The current is adjustable from 10 to 100% in 1% increments. The current can also be set to Off by going below 10%
Default	The default value for the current parameter is Off.

Detect Dly (detect delay)

Description	The detect delay time parameter sets the period of time that the motor current must be less than the current level before an under current trip will occur.
Values	The detect delay time parameter can be set from 0.1 to 90.0 seconds in 0.1 second intervals.
Default	The default value for the detect delay time parameter is 0.1 seconds.

Release DI (release delay)

General	The release delay time sets how long the relay is energized after the under current condition is cleared. This parameter is only functional if a relay has been programmed to UCT (under current trip) in the relay sub-menu (see page 87) and the fault has been disabled in the fault classes sub-menu (see page 84).
Values	The release delay time parameter can be set from 1.0 to 90.0 seconds in 0.1 second intervals
Default	The default value for the release delay time parameter is 10.0 seconds.

5.22 PROGRAMMING: Motor Protection - Start Lockouts

Starts/Hou (starts per hour)

Description	<p>The starts per hour parameter will set the number of allowed starts in one hour. If the starter has been stopped and the number of starts given in the last hour has exceeded this setting, the starter will display SPH in the top left of the display and the time, in minutes, until the next start is allowed in the bottom left of the display.</p> <p>NOTE: Starts/Hou does not increment on a PORT restart.</p>
Values	<p>The starts per hour is adjustable from 1 to 20 starts, in 1 start intervals. The starts per hour can also be set to Off by going below 1.</p>
Default	<p>The default value for the starts per hour parameter is Off.</p>

Time Start (time between starts)

Description	<p>The time between starts parameter sets the minimum allowed time between starts. Once a start command has been given, the next start cannot be performed until this time has expired. If the starter is stopped and the time between starts has yet to expire, the starter will display TBS in the top left of the display and the time, in minutes, until the next start is allowed in the bottom left of the display.</p> <p>NOTE: Time Start does not increment on a PORT restart.</p>
Values	<p>The time between starts is adjustable from 1 to 600 minutes, in 1 minute intervals. The time between starts can also be set to Off by going below 1 minute.</p>
Default	<p>The default value for the time between starts parameter is Off.</p>

BKS Timer (backspin timer)

Description	<p>The backspin timer parameter sets the minimum time between a stop and the next allowed start. If the starter is stopped and a time has been set, the starter will display BKS in the top left of the display and the time, in minutes, until the next allowed start in the bottom left.</p> <p>NOTE: The BKS Timer does not increment on a PORT restart.</p>
Values	<p>The backspin timer is adjustable from 1 to 200 minutes, in 1 minute intervals. The backspin timer can also be set to Off by going below 1 minute.</p>
Default	<p>The default value for the backspin timer parameter is Off.</p>

5.23 PROGRAMMING: Motor Protection - Starting Timers

UTS Timer (up-to-speed timer)

Description	<p>The up-to-speed timer parameter sets the maximum acceleration time to full speed that the motor can take. A stalled motor condition will be detected if the motor does not get up-to-speed before the up-to-speed timer expires. This allows the programming of a maximum acceleration time for the motor. The motor is considered up-to-speed once the current stabilizes below 175 percent of the FLA value and the ramp time expires.</p> <p>NOTE: The up-to-speed timer has to be set to a time that is greater than the highest ramp time in use. The up-to-speed timer will not automatically change to be greater than the ramp time. If a ramp time greater than the up-to-speed timer is set, the starter will display a up-to-speed fault every time a start is attempted.</p> <p>Fault Code 74 - Up to Speed Fault will be displayed when a stalled motor condition is detected.</p>
Values	<p>The up-to-speed timer parameter can be set from 1 to 300 seconds. The up-to-speed timer can be set to Off by setting it below 1 second.</p>
Default	<p>The default value for the up-to-speed timer parameter is 30 seconds.</p>

Zero Speed

Description	<p>When using the zero speed stall protection, the starter will start monitoring the zero speed input (at JC13-8) as soon as a run command is given and will recognize a stalled motor if the zero speed time has elapsed before the zero speed signal is removed. The zero speed input requires a 120VAC signal to indicate the zero speed condition.</p> <p>Fault Code 69 - Zero Speed Timer will be displayed when a stalled motor condition is detected.</p> <p>NOTE: The zero speed timer is not available on synchronous starters.</p>
Values	<p>The zero speed parameter can be set from 1 to 30 seconds, The zero speed timer can be set to Off by setting it below 1 second.</p>
Default	<p>The default value for the zero speed parameter is Off.</p>

5.24 PROGRAMMING: Motor Protection - Permissive Input

Therm. In

Description	The trip input parameter sets the time that power must be removed from the 120VAC input at JC13 terminal #1 on the RediStart Micro II CPU card before a fault occurs. When an external fault occurs, the starter will shut down and display a Fault 75 - External Fault.
Values	The trip input parameter can be set from 0.1 to 90.0 seconds in 0.1 second intervals.
Default	The default value for the trip input parameter is 0.5 seconds.

5.25 PROGRAMMING: Motor Protection - Misc.

Phase Orde (phase order)

Description	The line phasing parameter sets the phase sensitivity of the starter. This can be used to protect the motor from a possible change in the incoming phase sequence. If the incoming phase sequence does not match the set phase rotation, the starter will display phs err while stopped and will fault if a start is attempted.
Values	The line phasing can be set to; <ul style="list-style-type: none">• Ins - will run with either phase sequence• ABC - will only run with ABC phase sequence• CBA - will only run with CBA phase sequence
Default	The default value for the phase sensitivity parameter is Ins.

Auto RST (number of auto resets)

Description	<p>The number of auto resets parameter sets how many times in one hour the RediStart Micro II will reset a non-critical fault.</p> <p>This parameter is used in conjunction with the automatic fault reset jumper JPC19 (see page 26) and with the fault classes sub-menu (see page 84). When JPC19 is placed in the automatic fault reset position (1-2), this parameter sets how many times in one hour any non-critical faults are reset. Non-critical faults are set in the fault classes sub-menu (see page 84).</p>
Values	The number of auto resets parameter can be set from 1 to 5.
Default	The default value for the number of auto resets parameter is 4.

No Main PW (no main power)

Description	The no mains power delay parameter sets the period of time that the starter must have a run command without mains power before a no mains fault will occur.
Values	The no mains power delay parameter is adjustable from 1 to 5 seconds in 1 second intervals
Default	The default value for the no mains power parameter is 1 second.

5.26 PROGRAMMING: Motor Protection - Fault Classes

Fault Classes

Description

The fault classes menu allows the user to change the action taken when a fault occurs. The menu will allow every fault to be given a different classification depending on the user requirements. This allows the user to set the starter to;

- Trip the starter and display the fault code and description if it occurs.
- Ignore the fault if it occurs and continue to run.
- Activate a relay if the fault occurs and continue to run.

Note: Not all faults can be assigned every classification. Faults critical to starter operation may only be programmed to non-critical (NonC) and/or critical (Crit).

Values

Each fault can be classified as;

- NonC - Non-critical fault. Starter will trip. Resets if JPC19 set to 1-2.
- Crit - Critical fault. Starter will trip and require a manual reset.
- Dis - Fault is disabled. No action will be taken when fault occurs.
- WrnA - Fault will not trip starter. Energizes relay programmed to WrnA.
- WrnB - Fault will not trip starter. Energizes relay programmed to WrnB.
- WrnC - Fault will not trip starter. Energizes relay programmed to WrnC.

Note: Each relay output can be assigned to as many different faults as required.

Default

The default value for each fault depends on the fault.

5.27 PROGRAMMING: Meters & Relays - Meter Setup

Meter #1 , Meter #2

Description

The RediStart Micro II displays two meter functions on the right side of the display. These parameters set what each meter will display. The meter locations are as shown.

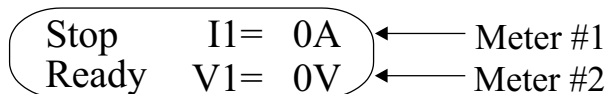

Values

The meter#1 display and meter#2 display parameters can each be set to one of the following:

- Asc - Each phase current in a scrolling manner.
- Aav - Average current.
- A1 - Phase 1 current.
- A2 - Phase 2 current.
- A3 - Phase 3 current.
- Vsc - Each phase voltage in a scrolling manner.
- Vav - Average voltage.
- V1 - Phase 1 voltage.
- V2 - Phase 2 voltage.
- V3 - Phase 3 voltage.
- Hz - Frequency.
- O/L - Thermal overload in percentage from 0% to 100% (100% = Trip).
- pf - Motor power factor.
- etm - The elapsed running time in tenths of an hour.
- Hetm - The elapsed running time in hours.
- Uetm - The user resettable elapsed running time.
- Ustr - The user resettable motor starts counter.
- KW - Motor real power consumption.
- KWH - Kilo-watt-hours used by the motor.
- MWH - Mega-watt-hours used by the motor.
- KVar - Motor reactive power consumption.
- KVA - Motor apparent power consumption.
- Tv - Tachometer voltage.
- %s - Maximum speed in percentage.
- Ms - Motor speed.
- GDF - Ground fault current in amps.
- Srts - Motor starts counter.
- Ibal - Motor current imbalance in percentage.
- ComR - The number of communication requests received.
- ComT - The number of communication transmits sent.
- CRat - The communications rate.
- RTD#? - The temperature being read by RTD with the number ?.
- TAmx - The maximum temperature being read by a RTD.
- TSmx - The maximum temperature being read by a stator RTD.
- TBmx - The maximum temperature being read by a bearing RTD.
- TApk - The peak temperature being read by a RTD.
- TSpk - The peak temperature being read by a stator RTD.
- TBpk - The peak temperature being read by a bearing RTD.
- IAmx - The number of the RTD reading the highest temperature.
- ISmx - The number of the RTD reading the stator highest temperature.
- IBmx - The number of the RTD reading the highest bearing temperature.
- IApk - The number of the RTD reading the peak temperature.
- ISpk - The number of the RTD reading the peak stator temperature.
- IBpk - The number of the RTD reading the peak bearing temperature.
- TT% - Calculated TruTorque torque value in % of Micro II torque units.

Default

The default value for the meter #1 display parameter is Asc.
The default value for the meter #2 display parameter is Vsc.

5.27 PROGRAMMING: Meters & Relays - Meter Setup

NOTE: The following meters will show a single decimal place when below the AutoRange setpoint: etm, Hetm, Uetm, KW, KWH, MWH, KVar, KVA. The value will show MAX and stop incrementing when they reach (6553). All other meters will show MAX when they reach (9999).

AutoRange

Description	The autorange parameter sets the value where the display meter will change ranges.
Values	The autorange can be set from 50.0 to 99.9 in 0.1 intervals.
Default	The default value for the autorange parameter is 99.9.

Meter Rsts (meter resets)

Description	The meter resets parameter allows the user to reset the different RediStart Micro II meters.
Values	<p>The meter resets can be set to the following;</p> <ul style="list-style-type: none">• None - No meter resets.• KWH - Reset the kilo-watt hour meter.• RunT - Reset the user run time hours meter.• Strt - Reset the user number of starts counter.• SCtr - Reset the serial communication counters.• RTDP - Reset the peak RTD meters. <p>When set to any of these values, the parameter will automatically return to None but the meter will be reset.</p>
Default	The default value for the meter resets parameter is None.

Scroll Tim (scroll time)

Description	The scroll time parameter sets the delay time between display pages. If this is set to a time, the display will switch between different pages which will show all the different metering values. See page 29 for a description of the display pages. If this is set to Off, the display pages can be viewed by pressing the Up or Down buttons.
Values	The scroll time is adjustable from 1 second to 120 seconds in 1 second intervals. The meter scroll time can also be turned Off.
Default	The default value for the scroll time is Off.

5.28 PROGRAMMING: Meters & Relays - Standard Relays

Relay#1, K5 and Relay#2, K6

Description

The relay #1, K5 and relay #2, K6 parameters set the functionality of the two programmable relays on the RediStart Micro II power card (see power card layout on page 119).

The relay #1 default is RUN so it should be used to control an in-line contactor or for any other operation requiring a run contact. The relay #2 default is UTS so it should always be used to control a bypass contactor or for any other operation requiring an up-to-speed signal.

The shunt trip (SHT) contact option will change the relay state on various fault scenarios. If the automatic fault reset jumper is set to manual, this relay will change state on any fault. If the automatic fault reset jumper is set to automatic, this relay will change state on any critical fault or the number of auto resets parameter value has been reached (see page 83).

Values

The relay #1 output and relay #2 output can each be set to one of the following;

- OL - The thermal overload has tripped.
- OLL - The thermal overload is locking out starter operation.
- OLW - The thermal overload is above 90% content and about to trip.
- RUN - The starter is running.
- UTS - The motor is running at full speed.
- SCR - The starter has detected a shorted SCR.
- SHT - Provides a shunt trip output for tripping a circuit breaker.
- GDF - Changes state when a ground fault condition is detected.
- OCT - Changes state when an over-current condition is detected.
- UCT - Changes state when an under-current condition is detected.
- TL - Unit has sensed a tachometer loss.
- FBp - Energize a bypass contactor connected for the forward direction.
- RBp - Energize a bypass contactor connected for the reverse direction.
- FvR - The starter is running in the forward direction.
- RvR - The starter is running in the reverse direction.
- FUS - The motor is running at full speed in the forward direction.
- RUS - The motor is running at full speed in the reverse direction.
- JOG - Starter is operating in the jog at set speed mode.
- BRK - Starter is providing D.C. brake current to the motor.
- PORT - Starter is in Power Outage Ride Thru mode.
- HEAT - The motor winding heater is active.
- RDY - All conditions ready to run.
- RM#1 - Remote MODBUS operated contact #1.
- RM#2 - Remote MODBUS operated contact #2.
- RM_R - Remote communications run contact.
- RTDw - A RTD is sensing a temp. over it's programmed warning level.
- RTDa - A RTD is sensing a temp. over it's programmed alarm level.
- RTDf - A RTD has failed either open or shorted.
- WrnA - Fault warning relay for faults set to a WrnA classification.
- WrnB - Fault warning relay for faults set to a WrnB classification.
- WrnC - Fault warning relay for faults set to a WrnC classification.

Default

The default value for the relay #1 output parameter is RUN.
The default value for the relay #2 output parameter is UTS.

5.29 PROGRAMMING: Meters & Relays - Extended Relays

Opt. #?, K?

Description

The optional #?, K? (where ? represents the relays numbered 1 to 7) parameters set the functionality of the four or seven programmable relays on the optional relay cards.

If the optional four (4) relay card is used, only parameters #1 to #4 will each set the operation of one of the relays on the card (see the four relay card layout on page 121).

If the optional seven (7) relay card is used, then parameters #1 to #7 will each set the operation of one of the relays on the card (see the seven relay card layout on page 121).

NOTE: If communications is enabled. Optional Relay #4 will be fixed as RM_R.

Values

The optional #x, Kx output can each be set to one of the following;

- OL - The thermal overload has tripped.
- OLL - The thermal overload is locking out starter operation.
- OLW - The thermal overload is above 90% content and about to trip.
- RUN - The starter is running.
- UTS - The motor is running at full speed.
- SCR - The starter has detected a shorted SCR.
- SHT - Provides a shunt trip output for tripping a circuit breaker.
- GDF - Changes state when a ground fault condition is detected.
- OCT - Changes state when an over-current condition is detected.
- UCT - Changes state when an under-current condition is detected.
- TL - Unit has sensed a tachometer loss.
- FBp - Energize a bypass contactor connected for the forward direction.
- RBp - Energize a bypass contactor connected for the reverse direction.
- FvR - The starter is running in the forward direction.
- RvR - The starter is running in the reverse direction.
- FUS - The motor is running at full speed in the forward direction.
- RUS - The motor is running at full speed in the reverse direction.
- JOG - Starter is operating in the jog at set speed mode.
- BRK - Starter is providing D.C. brake current to the motor.
- PORT - Starter is in Power Outage Ride Thru mode.
- HEAT - The motor winding heater is active.
- RDY - All conditions ready to run.
- RM#1 - Remote MODBUS operated contact #1.
- RM#2 - Remote MODBUS operated contact #2.
- RM_R - Remote communications run contact.
- RTDw - A RTD is sensing a temp. over it's programmed warning level.
- RTDa - A RTD is sensing a temp. over it's programmed alarm level.
- RTDf - A RTD has failed either open or shorted.
- WrnA - Fault warning relay for faults set to a WrnA classification.
- WrnB - Fault warning relay for faults set to a WrnB classification.
- WrnC - Fault warning relay for faults set to a WrnC classification.

Default

The default values vary with the starter model and options supplied.

5.30 PROGRAMMING: Event Recorder

Event Recorder

Description

The event recorder stores the last 99 events. An event is anything that changes the present state of the starter. Examples of events include an operation fault, a Start command, or a Stop command.

When the event recorder is entered, the last (newest) event is displayed. This is event number 00 as shown in the bottom right side of the display. To look at the events from the newest to oldest, press the Up button to advance from event 01 to 99.

Event Recorder Layout

The first screen that is displayed in the event recorder gives the starter state on the second line of the display. See below;

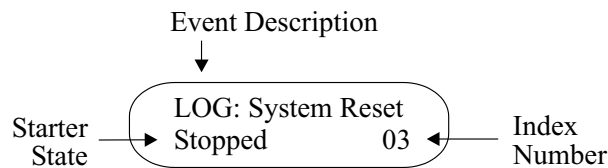

The time of the event can be displayed on the bottom line of the display by pressing the Enter button once. See below;

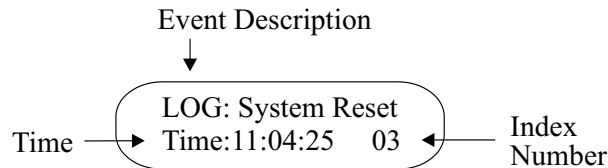

The date of the event can be displayed on the bottom line of the display by pressing the Enter button twice. See below;

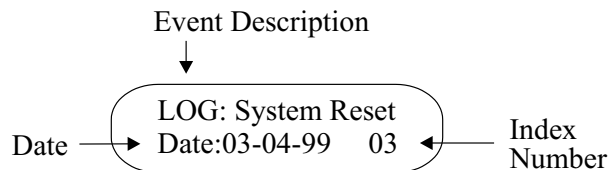

The fault/Log number can be displayed on the bottom line of the display by pressing the Enter button three times. For more information on the fault, look up the fault number in the table on page 108. See below;

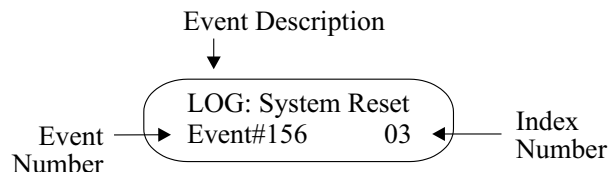

Press the Enter button again to return to the first display screen.

5.30 PROGRAMMING: Event Recorder

Event Description

The top line of the event recorder lists the event description. The two things that can be listed in the event recorder are a change in the state of the starter or a fault. A change in the state of the starter is listed in the event recorder with "Log:" before the description. A fault that occurred is just listed in the event recorder by its description.

Starter State

The starter state lists what state the starter was in when the event occurred. The possible states are listed below;

Message	Run Command	Jog Command * (JC13-4)	Reverse Command * (JC13-6)	Heater Command * (JC13-8)	Ramp #2 Command (JC13-9)	Power to Motor	Motor At Full Speed
Faulted							
FWD1/RUN:RAMP	X					X	
FWD2/RUN:RAMP	X				X	X	
REV1/RUN:RAMP	X		X			X	
REV2/RUN:RAMP	X		X		X	X	
FWD1/RUN:UTS	X					X	X
FWD2/RUN:UTS	X				X	X	X
REV1/RUN:UTS	X		X			X	X
REV2/RUN:UTS	X		X		X	X	X
FWD1/RUN:BRK						X	
FWD2/RUN:BRK					X	X	
REV1/ RUN:BRK			X			X	
REV2/ RUN:BRK			X		X	X	
FWD1/RUN:DEC						X	
FWD2/RUN:DEC					X	X	
REV1/RUN:DEC			X			X	
REV2/RUN:DEC			X		X	X	
FWD1/RUN:STOP							
FWD2/RUN:STOP					X		
REV1/RUN:STOP			X				
REV2/RUN:STOP			X		X		
FWD1/JOGGING	X	X				X	
FWD2/JOGGING	X	X			X	X	
REV1/JOGGING	X	X	X			X	
REV2/JOGGING	X	X	X		X	X	
FWD1/JOG:STOP		X					
FWD2/JOG:STOP		X			X		
REV1/JOG:STOP		X	X				
REV2/JOG:STOP		X	X		X		
FWD1/HEATING	X			X		X	
FWD2/HEATING	X			X	X	X	
REV1/HEATING	X		X	X		X	
REV2/HEATING	X		X	X	X	X	
FWD1/HET:STOP				X			
FWD2/HET:STOP				X	X		
REV1/HET:STOP			X	X			
REV2/HET:STOP			X	X	X		

* = available on 100 - 1000VAC units only

Time

The time gives the time of day that the event occurred. The format is hours:minutes:seconds.

Date

The date gives the day on which the event occurred. The format is month-day-year.

Fault/Log Number

The fault/log number can be used when referring to the event. This number, along with the fault description, will be shown on the display at the time the fault occurred and caused the starter to trip. The number can also be referred to in the fault table on page 108 for a more detailed description of the fault as well as some possible solutions.

5.31 PROGRAMMING: Control Config - System Clock

System Clock

Description	<p>The RediStart Micro II comes with a real time clock. The user can enter the actual time and the starter will use this time when it logs events in the event recorder. This can help with troubleshooting.</p> <p>The RediStart Micro II clock is year 2000 compatible.</p>
Restrictions	<p>The RediStart Micro II clock can not be set if there is a starter lockout timer is present or if the factory password has been entered.</p>
Minutes	<p>The minutes parameter should be set to the present minute.</p>
Hours	<p>The hours parameter should be set to the present hour using 24 hour convention.</p>
Day	<p>Enter the current day of the month</p>
Month	<p>Enter the current month of the year.</p>
Year	<p>Enter the current year.</p>

5.32 PROGRAMMING: Control Config - System Password

Password

Description	<p>The system password protection will lock out the adjustment of all parameters except for the meter #1 display and meter #2 display.</p> <p>The RediStart Micro II is shipped with the password feature disabled. This is confirmed by a password setting of Off. When the password has been set, a password of 500 appears under this parameter.</p>
Setting the Password	<p>To set a password, change the value of the password from Off to any user selected number between 001 and 999, excluding 500.</p> <p>To make the password active, press the computer reset button, change the password to 500, or cycle the control power.</p> <p>When the parameters are password protected, a dot will appear in the bottom middle of the display and the password will be 500 when the password menu is entered.</p>
Removing the Password	<p>To remove the password protection, change the value of the password from 500 to the user selected number. Once this is done, change the password to Off. This will remove the user selected password and disable the password protection. The password can not be set to off unless the correct password has been entered.</p> <p>To change any parameter when a password is set, change the password from 500 to the user selected number. Once the parameter has been changed, press the computer reset button or change the password to any other value except for Off.</p>
Values	<p>The password can be set to any value between 001 and 999, excluding 500. The password can also be set to Off by setting it under 001.</p>
Default	<p>The default value for the password parameter is Off.</p>

5.33 PROGRAMMING: Control Config - Comm. Settings

COMM. Mode (communications mode)

Description	<p>The communications mode parameter sets the mode of serial communications.</p> <p>The starter requires the addition of a serial communications card to be able to use serial communications. See the RS232/RS485 Communications Manual for details on serial communications.</p> <p>The starter is capable of DeviceNet communications without any additional hardware. See the DeviceNet manual for details.</p>
Values	<p>The communications mode can be set to the following values:</p> <ul style="list-style-type: none">OFF - Serial communications is disabled.M232 - Use RS-232 serial communications with MODBUS RTU protocol.M485 - Use RS-485 serial communications with MODBUS RTU protocol.A232 - Use RS-232 serial communications with Benschaw ASCII protocol.A485 - Use RS-232 serial communications with Benschaw ASCII protocol.DNet - Use DeviceNet communications.
Default	<p>The default value for the communications mode parameter is OFF.</p>

COM Address (communications address)

Description	<p>The communications address parameter sets the starter address when using RS-485 communications. The equipment that is communicating with the RediStart Micro II must use the same address as this to communicate with the starter.</p>
Values	<p>The communications address can be set from 0 to 255.</p>
Default	<p>The default value for the communications address is 127.</p>

COM Delay (communications delay)

Description	<p>The communications delay parameter sets the delay time between the starter receiving a communications request and it responding to the request. The communications delay may have to be increased to give the equipment that sent the communications request enough time to switch to receiving mode before the response is sent.</p>
Values	<p>The communications response delay can be set from 0.02 to 2.00 seconds in 0.01 second intervals.</p>
Default	<p>The default value for the communications response delay is 0.35 seconds.</p>

5.33 PROGRAMMING: Control Config - Comm. Settings

MB:Baud (MODBUS baud rate)

Description	The MODBUS baud rate parameter sets the communications speed. NOTE: The RediStart Micro II must be reset after this parameter is changed.
Values	The MODBUS baud rate parameter can be set to; <ul style="list-style-type: none">• 2400 - 2400 bits per second.• 4800 - 4800 bits per second.• 9600 - 9600 bits per second.
Default	The default value for the MODBUS baud rate parameter is 2400 bits per second.

MB:Com T/O (MODBUS communications timeout)

General	The MODBUS communications timeout sets the time that the serial port controlled relays will stay energized without receiving a valid communications request. If a valid serial communications request is not received for the time that is set, the starter will de-energize the relays. The relays that are affected by this parameter are the RM#1, RM#2 and RM_R relays.
Values	The MODBUS communications timeout can be set from 1 to 900 seconds in 1 second intervals. It can also be set to Off by going below 1 second.
Default	The default value for the MODBUS communications timeout parameter is Off.

DN:MAC ID (DeviceNet MAC ID)

General	The DeviceNet MAC ID sets the address for the starter as a DeviceNet node. NOTE: The RediStart Micro II must be reset after this parameter is changed.
Values	The DeviceNet MAC ID can be set from 0 to 63.
Default	The default value for the DeviceNet MAC ID is 63.

DN:Baud (DeviceNet baud rate)

General	The DeviceNet baud rate sets the DeviceNet communications speed. NOTE: The RediStart Micro II must be reset after this parameter is changed.
Values	The DeviceNet baud rate parameter can be set to; <ul style="list-style-type: none">• 125 kbps• 250 kbps• 500 kbps
Default	The default value for the DeviceNet baud rate is 125 kbps.

5.33 PROGRAMMING: Control Config - Comm. Settings

DN:InAssy (DeviceNet input assembly)

General The DeviceNet input assembly parameter sets the format for the input data. Refer to the DeviceNet manual for details.

NOTE: The RediStart Micro II must be reset after this parameter is changed.

Values The DeviceNet input assembly can be set to;

- 50
- 51
- 52
- 53
- 60
- 61

Default The default value for the DeviceNet input assembly is 61.

DN:OutAssy (DeviceNet output assembly)

General The DeviceNet output assembly parameter sets the format for the output data. Refer to the DeviceNet manual for details.

NOTE: The RediStart Micro II must be reset after this parameter is changed.

Values The DeviceNet output assembly can be set to;

- 1
- 2
- 3
- 100

Default The default value for the DeviceNet output assembly is 100.

DN:T/O Act (DeviceNet timeout action)

General The DeviceNet timeout action parameter selects what the RediStart Micro II does in the event that the DeviceNet connection times out.

Values The DeviceNet timeout action can be set to none or stop.

Default The default value for the DeviceNet timeout action is none.

DN:Rev (DeviceNet interface revision)

General The DeviceNet interface revision reports the revision stored in the Identity Object (class1, attribute 4). The revision refers to the set of objects and attributes implemented in the RediStart Micro II. As new objects and attributes are implemented, the revision will increase. The revision may be used to ensure the correct version of the DeviceNet manual and EDS file are obtained.

Values The revision is listed in the form Major, Minor.

5.34 PROGRAMMING: Control Config - Options List

Options List

Description

The options list menu provides a list of the installed options on the starter. It can be used to determine what options have been added to the starter.

Values

The following is a list of the possible options;

- RSM MICROII - RediStart Micro II reduced voltage software.
- Reversing - Starter has reversing capability.
- Braking - Starter has DC injection braking.
- HD Braking - Starter has heavy duty braking.
- Two Speed - Starter is for two speed motor.
- MV Series - Medium Voltage 2200 to 4800VAC.
- Tachometer - Starter has tach feedback for linear ramp.
- Jog/Heater - Starter has jog and motor heater.
- SYNC - Starter has synchronous motor control.
- SEP - Stand-alone synchronous field controller.
- PORT - Power-outage ride through.
- ID Motor - Inside-delta motor starter.
- Dyn. Brake - Synchronous motor braking using field DC.

NOTE: Some options are not available on some starter series. For example, reversing and braking are not available on a medium voltage starter. Contact Benschaw for details.

5.35 PROGRAMMING: Control Config - Software Part#

	Software Part#
--	----------------

Description

The software part number sub-menu gives the part number of the software. This information is useful for future service reasons.

If calling Benshaw for service, this number should be recorded so it can be provided to the service technician.

Values

The following is a list of possible software part numbers. The xx represents the software revision number which changes as the software is updated.

- 810010-01-xx - LV standard soft-starter.
- 810010-02-xx - MV standard soft-starter.
- 810010-03-xx - LV Synch soft-starter.
- 810010-04-xx - MV Synch soft-starter.
- 810010-05-xx - LV Heavy Duty Brake soft-starter.
- 810010-06-xx - MV ATL Synch soft-starter.
- 810010-07-xx - MV extended soft-starter.
- 810010-08-xx - MV ATL soft-starter.
- 810011-xx-xx - Special releases.

* LV=low voltage and MV=medium voltage

5.36 PROGRAMMING: Factory Setup - Hardware Setup

C.T. Ratio

Description

The CT ratio must be set to match the CT's (current transformers) supplied with the starter. This allows the starter to properly calculate the current supplied to the motor.

Only Benshaw supplied CTs can be used on a RediStart Micro II starter. These are custom 0.2 amp secondary CTs specifically designed for use on the starter. The CT ratio is then normalized to a 1A secondary value. The supplied CT ratio can be confirmed by reading the part number on the CT label. The part number is of the form BICTxxx1M, where xxx is the CT primary and the 1 indicates the normalized 1 amp secondary.

Values

The CT ratio can be set to following values;

- 100 (:1 or 20:0.2)
- 288 (:1 or 58:0.2)
- 720 (:1 or 144:0.2)
- 864 (:1 or 173:0.2))
- 1000 (:1 or 200:0.2))
- 2640 (:1 or 528:0.2)
- 2880 (:1 or 576:0.2)
- 3900 (:1 or 780:0.2))
- 5000 (:1 or 1000:0.2)
- 5760 (:1 or 1152:0.2)

Default

The default value for the CT ratio is 288 (:1).

Relay Card

Description

The relay card parameter should be set to reflect the optionally installed relay card.

Values

The relay card can be set to;

- None - no relay card installed
- OUT4 - four relay output card installed
- OUT7 - seven relay output card installed

Default

The default value for the relay card parameter is None.

5.37 PROGRAMMING: Factory Setup - Factory Control

FACT Pass. (factory password)

Description	<p>The <u>factory password</u> parameter must be set to the <u>proper password</u> to allow access to the rest of this menu. The password is different for each day of the year. If it is required, Benschaw will supply the password for this menu for the day it is needed.</p> <p>NOTE: Entering a password will lock the System Clock to the set values, and it is not possible to enter the password twice in the same day.</p>
Values	The factory password is adjustable from 0 to 9999.
Default	The default value for the factory password parameter is 0.

Reset Def (reset to default parameters)

Description	When the Reset Def parameter is set to Yes, all parameters are reset to their default values.
Values	The Reset Def parameter can be set to No or Yes.
Default	The default value for the Reset Def parameter is No.

CLR Events (clear event log)

Description	When the CLR Events parameter is set to Yes, the event log is cleared of its events.
Values	The CLR Events parameter can be set to No or Yes.
Default	The default value for the CLR Events parameter is No.

CLR Pass. (clear password)

Description	If a System Password has been set through the Control Config. menu, setting the CLR Pass. parameter to Yes will clear this password.
Values	The CLR Pass. parameter can be set to No or Yes.
Default	The default value for the CLR Pass. parameter is No.

Cal Volt L1, L2, L3 (calibrate voltage meter)

Description	<p>If greater accuracy is desired for line voltage measurements, the Cal Volt L1, L2, L3 parameters can be used for calibration.</p> <p>NOTE: A calibrated voltage source or independent calibrated voltage meter is required.</p>
Values	The Cal Volt L1, L2, or L3 parameters are adjustable from 900 to 1100 volts in 1 volt increments.
Default	The default value for the Cal Volt L1, L2, or L3 parameter is 1000 volts.

5.37 PROGRAMMING: Factory Setup - Factory Control

Cal Curr L1, L2, L3 (calibrate current meter)
--

Description	<p>If greater accuracy is desired for line current measurements, the Cal Curr L1, L2, L3 parameters can be used for calibration.</p> <p>NOTE: A calibrated current source or independent calibrated current meter is required.</p>
Values	<p>The Cal Curr L1, L2, or L3 parameters are adjustable from 900 to 1100 amps in 1 amp increments.</p>
Default	<p>The default value for the Cal Curr L1, L2, or L3 parameter is 1000 amps.</p>

5.38 PROGRAMMING: RTD Setup - RTD Module Setup

Mod#1 Addr (module #1 address)

Description	The module #1 address parameter has to be set to the MODBUS address of the first RTD module attached to the soft-starter. The address of the RTD module can be verified by checking the rotary switch on the top of the RTD module.
Values	The RTD module #1 address can be set from 16 to 23 in increments of 1.
Default	The default value for the RTD module #1 address is 16.

Mod#2 Addr (module #2 address)

Description	The module #2 address parameter has to be set to the MODBUS address of the second RTD module attached to the soft-starter. The address of the RTD module can be verified by checking the rotary switch on the top of the RTD module. Ensure that module #2 is not set to the same address as module #1.
Values	The RTD module #2 address can be set from 16 to 23 in increments of 1.
Default	The default value for the RTD module #2 address is 17.

#RTDs Mod1 (number of RTDs on module #1)

Description	The number of RTDs on module 1 parameter sets the number of RTD inputs that are being used on first RTD module. If this parameter is set to None, then the RediStart Micro II will not attempt to communicate with module #1.
Values	The # of RTD's on module 1 parameter can be set from 1 to 8. The parameter can also be set to None by going below 1.
Default	The default value for the # or RTD's on module 1 parameter is None.

#RTDs Mod2 (number of RTDs on module #2)

Description	The number of RTDs on module 2 parameter sets the number of RTD inputs that are being used on second RTD module. If this parameter is set to None, then the RediStart Micro II will not attempt to communicate with module #2.
Values	The # of RTD's on module 2 parameter can be set from 1 to 8. The parameter can also be set to None by going below 1.
Default	The default value for the # or RTD's on module 2 parameter is None.

Temp Scale (temperature scale)

Description	The temperature scale parameter sets the units used for temperature measurements.
Values	The temperature scale can be set to; <ul style="list-style-type: none">• C - All RTD temperature values and set points are in degrees Celsius.• F - All RTD temperature values and set points are in degrees Fahrenheit.
Default	The default value for the temperature scale is C (degrees Celsius).

5.39 PROGRAMMING: RTD Setup - RTD SetPnts 1-8

RTD#? Grp (RTD #? Group)

Description	The RTD #? group (where ? is the RTD number) parameter allows the user to assign the RTD to a specific group. The values from the RTD's that are assigned to a group are used to provide the meters for that group.
Values	The RTD #? group parameter can be set to; <ul style="list-style-type: none">• None - The RTD operates independently.• Stat - The RTD operates as part of the stator metering group.• Bear - The RTD operates as part of the bearing metering group.
Default	The default value for the RTD #? Group parameter is None.

RTD#? Warn (RTD #? warning level)

Description	The RTD #? warning (where ? is the RTD number) parameter sets the temperature that a warning will occur for that RTD.
Values	The RTD #? warning parameter is adjustable from 0 to 200°C or 32 to 392°F in 1° increments. If the parameter is set one step below the lowest temperature, the parameter can be set to Off.
Default	The default value for the RTD #? warning parameter is Off.

RTD#? Alm (RTD #? alarm level)

Description	The RTD #? alarm (where ? is the RTD number) parameter sets the temperature that a trip will occur for that RTD.
Values	The RTD #? alarm parameter is adjustable from 0 to 200°C or 32 to 392°F in 1° increments. The parameter can also be set to Off by going one step below the lowest temperature.
Default	The default value for the RTD #? alarm parameter is Off.

5.40 PROGRAMMING: RTD Setup - RTD SetPnts 9-16

RTD#? Grp (RTD #? Group)

Description	The RTD #? group (where ? is the RTD number) parameter allows the user to assign the RTD to a specific group. The values from the RTD's that are assigned to a group are used to provide the meters for that group.
Values	The RTD #? group parameter can be set to; <ul style="list-style-type: none">• None - The RTD operates independently.• Stat - The RTD operates as part of the stator metering group.• Bear - The RTD operates as part of the bearing metering group.
Default	The default value for the RTD #? Group parameter is None.

RTD#? Warn (RTD #? warning level)

Description	The RTD #? warning (where ? is the RTD number) parameter sets the temperature that a warning will occur for that RTD.
Values	The RTD #? warning parameter is adjustable from 0 to 200°C or 32 to 392°F in 1° increments. If the parameter is set one step below the lowest temperature, the parameter can be set to Off.
Default	The default value for the RTD #? warning parameter is Off.

RTD#? Alm (RTD #? alarm level)

Description	The RTD #? alarm (where ? is the RTD number) parameter sets the temperature that a trip will occur for that RTD.
Values	The RTD #? alarm parameter is adjustable from 0 to 200°C or 32 to 392°F in 1° increments. The parameter can also be set to Off by going one step below the lowest temperature.
Default	The default value for the RTD #? alarm parameter is Off.

5.40 PROGRAMMING: RTD Setup - RTD SetPnts 9-16

6.

TROUBLESHOOTING

6.1 TROUBLESHOOTING

LED Diagnostics

General

There are several LEDs located on the RediStart Micro II circuit cards. These LEDs can be used to help troubleshoot problems with the starter. Refer to the circuit card layouts for LED locations.

CARD	LED #	NAME	INDICATION
Computer	LEDC1	Watch Dog/Power Fail/ Reset	On when reset/CPU failure/control voltage failure.
	LEDC2	Control power	On if control voltage is present.
	NS	DeviceNet Network Status	See Devicenet manual.
	MS	DeviceNet Module Status	See DeviceNet manual.
Local I/O Controller Card	DE	Data Enable	On when card is transmitting data.
	TXD	Transmit Data	On when card is transmitting data.
	RXD	Receive Data	On when card is receiving data.
	LED1	Operation	Flashes when card is operating.
	LED2	Communication	On when valid data is recieved over the master link.
Power	LEDP1 LEDP2 LEDP3	SCR Status	Indicates forward SCR condition; Stop - LEDs must be on or the SCR is shorted. Start - LEDs will become dimmer as motor accelerates. Run - LEDs must be fully off or the SCR is open or misfiring.
Reversing/Braking	LED1 LED2	SCR status	Indicates Reverse SCR condition; Stop - LEDs must be on or the SCR is shorted. Start - LEDs will become dimmer as motor accelerates. Run - LEDs must be fully off or the SCR is open or misfiring.
Bypass	LED1	All bypass in	On when all bypass contactors are pulled-in.

Meter Tests

Resistance



The SCR's in the starter can be checked with a standard ohmmeter to determine their condition.

Remove power from the starter before performing these checks.

Check from L to T on each phase. The resistance should be over 50kohms.

Check between the gate leads for each SCR (red and white twisted pairs). The resistance should be from 8 to 50 ohms.

NOTE: The resistance measurements may not be within these values and the SCR may still be good. The checks are to determine if an SCR is shorted L to T or if the gate on an SCR is shorted or open. An SCR could also still be damaged even though the measurements are within the above specifications.

Voltage



When the starter is running, the operation of the SCR's can be confirmed with a voltmeter.

Extreme caution should be observed while performing these checks since the starter has lethal voltages applied while operating.

Using an AC voltmeter, check the voltage from L to T of each phase. The voltage should be less than 1.5 volts. If the starter has a bypass contactor, the voltage drop should be less than 0.3 volts.

Using a DC meter, check between the gate leads for each SCR. The voltage should be between 0.5 and 2.0 volts.

Integral Bypass



The voltage drop across the RediStart Micro II integral bypass contactors should be checked every six months to confirm they are operating correctly.

Extreme caution should be observed while performing these checks since the starter has lethal voltages applied while operating.

While the starter is running and up-to-speed, use an AC voltmeter and check the voltage from L to T for each phase. The voltage drop across the contactor should be less than 300mV. If the voltage is greater than 300mV, the integral bypass contactor should be disassembled. It may be necessary to clean the contact tips or replace the contactor.

Event Recorder

General

The RediStart Micro II has an event recorder which stores the event description, motor state, time, and date of the last 100 events that have occurred. An event is anything that changes the present state of the starter. Examples of events can include a start, a stop, an overload warning, or a fault. See page 89 for a complete description of the event recorder.

6.1 TROUBLESHOOTING

Fault/Log Codes

General

The following is a list of the possible fault and log codes that can be generated depending on the type of starter.

The fault class lists the default setting for each fault.

NOTE: Refer to page 90 for a list of the possible states the starter can be in when a fault/event occurs.

Fault/Log Number	Fault Class	Fault/Event Recorder Text	Description/Possible Solutions
1	NonC	Sequence Not CBA	<ul style="list-style-type: none"> Incoming phase sequence is actually ABC but starter is set to CBA (see page 83).
2	NonC	Sequence Not ABC	<ul style="list-style-type: none"> Incoming phase Sequence is actually CBA but starter is set to ABC (see page 83).
3	NonC	No Phase Order	<ul style="list-style-type: none"> No phase order detected.
4	NonC	High Freq. Trip	<ul style="list-style-type: none"> Line frequency went above the high freq. trip setting (see page 75). Line power quality problem. Low control power problem. Generator governor is malfunctioning.
5	NonC	Low Freq. Trip	<ul style="list-style-type: none"> Line frequency went below the low freq. trip setting (see page 75). Line power quality problem. Low control power problem. Generator governor malfunctioning.
6	NonC	Jog Not Allowed	<ul style="list-style-type: none"> The jog input (JC13-4) was energized while the starter was running. Stop the starter by removing the run command before requesting a jog (JC13-4).
7	NonC	100% Not Allowed	<ul style="list-style-type: none"> The jog input (JC13-4) was de-energized while the starter was operating in the jog mode. Stop the starter by removing the run command before removing the jog command (JC13-4).
9	NonC	Dir Change Fault	<ul style="list-style-type: none"> The jog direction was changed while the starter was operating in the jog mode. Stop the starter by removing the run command before changing the state of the reversing input (JC13-6).
15	Crit	Phase Order Err	<ul style="list-style-type: none"> Phase order error.
16	Crit	Bad OP Code Err	<ul style="list-style-type: none"> Bad op-code error.
17	NonC	Over voltage L1	<ul style="list-style-type: none"> The voltage on line 1 went above the high/low voltage setting (see page 74).
18	NonC	Over voltage L2	<ul style="list-style-type: none"> The voltage on line 2 went above the high/low voltage setting (see page 74).
19	NonC	Over voltage L3	<ul style="list-style-type: none"> The voltage on line 3 went above the high/low voltage setting (see page 74).
20	NonC	Low Line#1	<ul style="list-style-type: none"> The voltage on line 1 went below the high/low voltage setting (see page 74).
21	NonC	Low Line#2	<ul style="list-style-type: none"> The voltage on line 2 went below the high/low voltage setting (see page 74).
22	NonC	Low Line#3	<ul style="list-style-type: none"> The voltage on line 3 went below the high/low voltage setting (see page 74).
23	NonC	Curr. Imbal. HL1	<ul style="list-style-type: none"> The current on line 1 went above the current imbalance setting (see page 72).
24	NonC	Curr. Imbal. HL2	<ul style="list-style-type: none"> The current on line 2 went above the current imbalance setting (see page 72).
25	NonC	Curr. Imbal. HL3	<ul style="list-style-type: none"> The current on line 3 went above the current imbalance setting (see page 72).

6.1 TROUBLESHOOTING

Fault/Log Number	Fault Class	Fault/Event Recorder Text	Description/Possible Solutions
26	NonC	Curr. Imbal. LL1	<ul style="list-style-type: none"> The current on line 1 went below the current imbalance setting (see page 72).
27	NonC	Curr. Imbal. LL2	<ul style="list-style-type: none"> The current on line 2 went below the current imbalance setting (see page 72).
28	NonC	Curr. Imbal. LL3	<ul style="list-style-type: none"> The current on line 3 went below the current imbalance setting (see page 72).
29	Crit	Bad RAM Battery	<ul style="list-style-type: none"> Bad RAM battery. Replace IC16 or computer card to correct problem. To clear fault, hold the down arrow key and perform a computer reset. Continue holding the down arrow key until fault 30 appears on the display.
30	Crit	Def Param Loaded	<ul style="list-style-type: none"> The factory defaults for the parameters have been loaded. Reset the computer to clear the fault. All parameters have to be re-programmed as necessary.
31	NonC	REV Not Allowed	<ul style="list-style-type: none"> Starter is not a reversing unit. Remove reverse command from reverse input (JC13-6).
46	NonC	BIST Canceled	<ul style="list-style-type: none"> The Built-in Self Test was canceled. The disconnect was closed. Line power was applied to the starter.
49	NonC	Tach Loss	<ul style="list-style-type: none"> There was no tachometer feedback signal detected when a start was commanded.
50	Crit	Key Pad Failure	<ul style="list-style-type: none"> The door mounted keypad has failed. The Stop or Start button was held down while a computer reset was performed or while power was applied to the unit.
51	Crit	TT Overcurrent Limit	<ul style="list-style-type: none"> During TruTorque ramping, the motor current exceeded the TruTorque Overcurrent Trip level (see page).
52	Crit	Curr. At Stop	<ul style="list-style-type: none"> Current flow above the no current at run setting (see page 73) was detected while the starter was stopped. Examine starter for shorted SCRs.
53	NonC	No Curr. At Run	<ul style="list-style-type: none"> The motor current went below the no current at run setting (see page 73) while the starter was running. The load was disconnected while running. The motor is being driven by the load.
56	NonC	Phase Detection	<ul style="list-style-type: none">
64	Dis	Bad RTD Detected	<ul style="list-style-type: none"> A bad RTD was detected (open or shorted lead).
65	NonC	RTD Alarm Limit	<ul style="list-style-type: none"> A RTD alarm set point was exceeded.
66	NonC	RTD Comm Loss	<ul style="list-style-type: none"> Communications with the RTD module was lost. Check RS-485 wiring between the RTD module and card. Check 24VDC RTD module power supply.
67	NonC	PWR DIP data Los	<ul style="list-style-type: none"> PWR DIP data lost.
68	NonC	Jog Timer Limit	<ul style="list-style-type: none"> The jog timer (see page 59) expired. Examine reason for extended jog operation.
69	NonC	Zero Speed Timer	<ul style="list-style-type: none"> The zero speed timer (see page 81) expired. Check motor for jammed or overloaded condition.
70	NonC	Low Control PWR	<ul style="list-style-type: none"> Control power is too low. Examine control power transformer input and output voltages. Check wiring between control power source and starter.
71	NonC	Ground Fault	<ul style="list-style-type: none"> A ground fault current above the ground fault setting was detected. Refer to page 76 for the ground fault settings. Megger motor and cabling (disconnected from starter).
72	Crit	DIP SW set Wrong	<ul style="list-style-type: none"> CT burden DIP switch set incorrectly. Set switches correctly (see page 24).
73	NonC	Bypass Fault	<ul style="list-style-type: none"> The bypass contactor failed to stay energized. Check separate bypass for proper wiring. Check integral bypass (RSxB units) control card fuses.

6.1 TROUBLESHOOTING

Fault/Log Number	Fault Class	Fault/Event Recorder Text	Description/Possible Solutions
74	NonC	UTS Timer Limit	<ul style="list-style-type: none"> The motor was not at full speed before the UTS time (see page 81) expired. Check motor for jammed or overloaded condition.
75	NonC	External Trip	<ul style="list-style-type: none"> Power was removed from the external trip input on the computer card (JC13-1). Trip input delay is set to short(see page 82).
76	Crit	Disconnect Open	<ul style="list-style-type: none"> A start was commanded while the disconnect was open.
77	NonC	In-line Fault	<ul style="list-style-type: none"> The in-line contactor did not close. Check wiring to coil of contactor. Check feedback wiring from auxiliary contactor to JC13-4 terminal. check in-line fault delay (see page 82).
78	NonC	Over Curr Trip	<ul style="list-style-type: none"> The current went above the over-current trip setting (see page 78).
79	NonC	Under Curr Trip	<ul style="list-style-type: none"> The current went below the under-current trip setting (see page 79).
80	NonC	High Field Curr.	<ul style="list-style-type: none"> The field current was above the maximum field current setting. Examine parameter settings for improper adjustment. Examine field for problem causing the high field current.
81	NonC	Field Loss	<ul style="list-style-type: none"> There was no synchronous field current. Check wiring and motor for open field circuit.
82	NonC	Loss of SYNC	<ul style="list-style-type: none"> The motor came out of synchronization while it was operating. Examine the motor load for an overload. Increase the field current up to the maximum for the motor. Change from power factor control to current control mode for a varying load.
83	NonC	High PF Trip	<ul style="list-style-type: none"> The motor power factor went above the high power factor trip setting.
84	NonC	Low PF Trip	<ul style="list-style-type: none"> The motor power factor went below the low power factor trip setting.
87	NonC	Incomplete Seq.	<ul style="list-style-type: none"> The motor was not synchronized before the sequence timer expired.
90	Crit	OL Lock	<ul style="list-style-type: none"> Used to set the operation of the overload.
91	Crit	Unauthorized RUN	<ul style="list-style-type: none"> The start/stop circuitry has failed. A fast start/stop sequence was performed. Check wire connected to terminal JC13-3.
92	Crit	Shorted SCR	<ul style="list-style-type: none"> A shorted SCR on line 1 was detected (Refer to page 77). Check all 3 SCRs for shorts (Refer to page 107).
93	Crit	Shorted SCR	<ul style="list-style-type: none"> A shorted SCR on line 2 was detected (Refer to page 77). Check all 3 SCRs for shorts (Refer to page 107).
94	Crit	Shorted SCR	<ul style="list-style-type: none"> A shorted SCR on line 3 was detected (Refer to page 77). Check all 3 SCRs with ohmmeter for shorts.
95	Crit	Shorted SCR	<ul style="list-style-type: none"> Shorted SCRs on line 2 and 3 were detected (Refer to page 77). Check all 3 SCRs with ohmmeter for shorts.
96	Crit	Shorted SCR	<ul style="list-style-type: none"> Shorted SCRs on line 1 and 3 were detected (Refer to page 77). Check all 3 SCRs with ohmmeter for shorts.
97	Crit	Shorted SCR	<ul style="list-style-type: none"> Shorted SCRs on line 1 and 2 were detected (Refer to page 77). Check all 3 SCRs with ohmmeter for shorts.
98	NonC	No Mains Power	<ul style="list-style-type: none"> A start was commanded while no line power was detected.
99	Crit	I. O. C.	<ul style="list-style-type: none"> A very high current was detected. Check the motor and wiring for short circuits.
101		Blank Log	<ul style="list-style-type: none"> Blank Log.
102		Log:Disconnect O	<ul style="list-style-type: none"> Log:Disconnect open.
103		Log:DIR Change	<ul style="list-style-type: none"> The direction of the starter was changed.
104		Start Commanded	<ul style="list-style-type: none"> A start command was given.

6.1 TROUBLESHOOTING

Fault/Log Number	Fault Class	Fault/Event Recorder Text	Description/Possible Solutions
105		Stop Commanded	<ul style="list-style-type: none"> A stop command was given.
106		Stop Complete	<ul style="list-style-type: none"> The stop sequence is complete and the starter has removed power from the motor.
107		Log: System UTS	<ul style="list-style-type: none"> Log: System UTS (up to speed).
147		Log:BIST Entered	<ul style="list-style-type: none"> Log:BIST entered.
148		Log:BIST Passed	<ul style="list-style-type: none"> Log:BIST passed.
154		Log:Password CLR	<ul style="list-style-type: none"> Log:Password cleared.
155		Log:Events CLR	<ul style="list-style-type: none"> Log:Event log cleared.
156		Log:System Reset	<ul style="list-style-type: none"> Log:System Reset.
157		Log:Hardware PWR UP	<ul style="list-style-type: none"> Log:Hardware PWR UP.
158		Log:Emerg Reset	<ul style="list-style-type: none"> Log:Emergency reset.
159		Log:Time Changed	<ul style="list-style-type: none"> Log:Time changed.
160		PWR Ret BYP IN	<ul style="list-style-type: none"> Line power returned while the bypass contactor was in.
161		PWR Ret BYP OUT	<ul style="list-style-type: none"> Line power returned after the bypass contactor was dropped out.
162		PWR Loss Voltage	<ul style="list-style-type: none"> PORT mode was entered due to low line voltage.
163		PWR Loss Current	<ul style="list-style-type: none"> PORT mode was entered due to loss of current.
164		PORT BYP Open	<ul style="list-style-type: none"> Bypass contactor was dropped out while in PORT mode.
165		Log:System Reset	<ul style="list-style-type: none"> The unit was reset.
169		RTD Warn Limit	<ul style="list-style-type: none"> One of the RTD warning set points was exceeded.
185		Log:Loss of SYNC	<ul style="list-style-type: none"> Log:Loss of SYNC.
186		Log:If Ctrl Mode	<ul style="list-style-type: none"> Log:If Ctrl Mode.
188		Log:By-Pass Drop	<ul style="list-style-type: none"> The integral bypass contactors dropped out and were re-energized. Possible short term drop in line voltage.
189		Log:OL Warn	<ul style="list-style-type: none"> The thermal overload went above 90% thermal content.
190		Log:OL Lock	<ul style="list-style-type: none"> The thermal overload tripped. Check motor and load for cause of overload.

6.1 TROUBLESHOOTING

General Troubleshooting Charts

General

The following troubleshooting charts can be used to help solve some of the more common problems that occur.

Motor will not start, no output to motor.

Display	Cause	Solution
Fault Displayed.	<ul style="list-style-type: none"> Shown on display. 	<ul style="list-style-type: none"> See fault code table.
Watchdog LED on.	<ul style="list-style-type: none"> CPU card problem. 	<ul style="list-style-type: none"> Consult factory.
Display is blank.	<ul style="list-style-type: none"> Control voltage is absent. FU1 on power card. Ribbon Cables. 	<ul style="list-style-type: none"> Check for proper control voltage. Replace FU1. Check ribbon cables.
Stopped	<ul style="list-style-type: none"> Control Devices Display buttons disabled. 	<ul style="list-style-type: none"> Check control devices. Enable display buttons.
No line	<ul style="list-style-type: none"> Missing at least one phase of main power 	<ul style="list-style-type: none"> Check power system.

Motor rotates but does not reach full speed.

Display	Cause	Solution
Fault displayed.	<ul style="list-style-type: none"> Shown on display. 	<ul style="list-style-type: none"> See fault code table.
Accel or Running.	<ul style="list-style-type: none"> Mechanical problems. Inadequate current limit setting. Improper parameter settings. Abnormally low line voltage. 	<ul style="list-style-type: none"> Check for load binding. Check motor. Increase maximum current setting. Check parameter settings. Fix line voltage problem

Deceleration profile not operating correctly.

Problem	Cause	Solution
Motor stops too quickly.	<ul style="list-style-type: none"> Time setting. Improper level setting. 	<ul style="list-style-type: none"> Increase the decel time. Increase decel level 1 and/or decel level 2.
Time seems correct but motor surges at start of decel.	<ul style="list-style-type: none"> Decel level 1. 	<ul style="list-style-type: none"> Decrease decel level 1 by 5% until surge is eliminated.
Time seems correct but motor stops before cycle complete.	<ul style="list-style-type: none"> Decel level 2. TruTorque DCL End Torque 	<ul style="list-style-type: none"> Increase decel level 2 by 5% until motor stops when decel cycle is complete. Increase TruTorque DCL End Torque by 5% until motor stops when decel cycle is complete.
Time seems correct but water hammer occurs at end of cycle.	<ul style="list-style-type: none"> Decel level 2. TruTorque DCL End Torque 	<ul style="list-style-type: none"> Decrease decel level 2 by 5% until water hammer is eliminated. Decrease TruTorque DCL End Torque by 5% until water hammer is eliminated.

6.1 TROUBLESHOOTING

Motor stops while running.

Display	Cause	Solution
Fault displayed.	<ul style="list-style-type: none"> Shown on display. 	See fault code table.
Display is blank.	<ul style="list-style-type: none"> Control voltage is absent. FU1 on power card. 	<ul style="list-style-type: none"> Check control wiring and voltage. Replace fuse.
Stopped	<ul style="list-style-type: none"> Control devices. 	<ul style="list-style-type: none"> Check control system.

Other situations.

Problem	Cause	Solution
Power Metering not working.	<ul style="list-style-type: none"> CT installed wrong. 	<ul style="list-style-type: none"> Fix CT installation. White dot to line side.
TruTorque Ramp not working.	<ul style="list-style-type: none"> CT installed wrong. 	<ul style="list-style-type: none"> Fix CT installation. White dot to line side.
Motor current or voltage fluctuates with steady load.	<ul style="list-style-type: none"> Motor. Energy saver. Power connection. SCR fault. 	<ul style="list-style-type: none"> Verify motor is operating correctly. Set energy saver to off. Shut off all power and check connections. Check SCR voltage L to T. Should be less than 1.5VAC during normal operation.
Erratic operation.	<ul style="list-style-type: none"> loose connections. 	<ul style="list-style-type: none"> Shut off all power and check connections.
Accelerates too quickly.	<ul style="list-style-type: none"> Ramp time. Initial current. Maximum current setting. Kick Start. Improper FLA setting. Initial torque. Maximum torque. 	<ul style="list-style-type: none"> Increase ramp time. Decrease initial current setting. Decrease maximum current setting. Lower Kick Start current or time. Check FLA setting. Decrease initial torque setting. Decrease maximum torque setting.
Accelerates too slowly.	<ul style="list-style-type: none"> Ramp time. Initial current. Maximum current setting. Kick Start. Improper FLA setting. Initial torque. Maximum torque. 	<ul style="list-style-type: none"> Decrease ramp time. Increase initial current setting. Increase maximum current setting. Increase Kick Start current or time. Check FLA setting. Increase initial torque setting. Increase maximum torque setting.
Motor overheats.	<ul style="list-style-type: none"> Duty cycle. High ambient. Too long acceleration time. Wrong overload setting. Too long jog cycle. 	<ul style="list-style-type: none"> Allow for motor cooling between starts. Provide better ventilation. Reduce motor load. Select correct overload setting. Jog operation reduces motor cooling and increases current. Shorten jog cycle.
Motor short circuit.	<ul style="list-style-type: none"> Wiring fault. Power factor correction capacitors (PFCC) on starter output. 	<ul style="list-style-type: none"> Identify fault and correct. Move PFCC to line side of starter.
Fans do not operate	<ul style="list-style-type: none"> Wiring. Fuse. Fan failed. 	<ul style="list-style-type: none"> Check wiring and correct. Replace fuse. Replace fan.
Display buttons don't work.	<ul style="list-style-type: none"> Display ribbon cable. Display faulty. 	<ul style="list-style-type: none"> Check faceplate cable on back of display. Replace display.

6.1 TROUBLESHOOTING

Spare Parts

Part Number	Description	Used On	Quantity
BIPC-300040-05	CPU card 240VAC control	All	1
BIPC-300040-08	CPU card DeviceNet	All	1
BIPCM1PWR-A4	Power card	All 100 to 1000VAC	1
BIPC-300030-01	Power card standard	100 to 575VAC	1
BIPC-300030-02	Power card 1000VAC	1000VAC	1
BIPC-300030-05	Power card tachometer	100 to 575VAC	1
BIPC-300030-07	Power card 240VAC control	100 to 575VAC	1
BIPCLCD	Display assembly	All	1
BIPCRSMB	Integral Bypass card	All integral bypass (RSMxB)	1
BIPC-300012-01	Reversing card	All reversing (RSM10 or RSM11)	1
BIPC-300012-01	Braking card	All Braking (RSM7 or RSM11)	1
BIPC-300013-01	4-Relay output card	Optional - All	1
BIPC-300029-01	7-Relay output card	Optional - All	1
BIPC-300000-04	RS-232 card	Optional - All	1
BIPC-300000-03	RS-485 card	Optional - All	1
BIPC-300042-02	RS-232/485 card	Optional - All	1
BIPC-300017-01	Local I/O Controller card (for RTD)	Optional - All	1
SPR-100P	Remote RTD Module 100Ω Platinum	Optional - All	1
BI-M-FU1	0.63A micro power card fuse	All	1
BPC-720	Integral bypass contactor	All integral bypass (RSMxB)	3
BISIOV	Voltage transient protector	All	3
BIPCDVDT-1L	1 phase DV/DT network card	Optional on >200 amp units	3
BIPCDVDT-3L	3 phase DV/DT network card	Optional on < 200 amp units	1
BICT2881M	288:1 current transformer	up to 50 amp units	3
BICT8641M	864:1 current transformer	51 amp to 200 amp units	3
BICT26401M	2640:1 current transformer	201 amp to 400 amp units	3
BICT57601M	5760:1 current transformer	> 400 amp units	3
BISCR5012X	50 amp low voltage SCR	< 28 amp units	3
BISCR7012X	70 amp low voltage SCR	29 amp to 42 amp units	3
BISCR10012X	100 amp low voltage SCR	43 amp to 54 amp units	3
BISCR13212X	132 amp low voltage SCR	55 amp to 68 amp units	3
BISCR16112X	161 amp low voltage SCR	69 amp to 80 amp units	3
BISCR21012X	210 amp low voltage SCR	81 amp to 130 amp units	3
BISCR25012X	250 amp low voltage SCR	131 amp to 124 amp units	3
BISCR6601818	660 amp low voltage SCR	125 amp to 248 amp units	6
BISCR8801830	880 amp low voltage SCR	249 amp to 384 amp units	6
BISCR15001850	1500 amp low voltage SCR	385 amp to 840 amp units	6

SCR Replacement

SCR Clamp

The SCR clamp pictured below is typical of the clamp used on all SCRs. The larger SCRs have two spring washer stacks and pressure indicating washers. These SCR clamps are precision clamps that allows easy installation to the proper SCR clamping pressure. They have a pressure indicator(s) that will become loose once the proper pressure is reached.

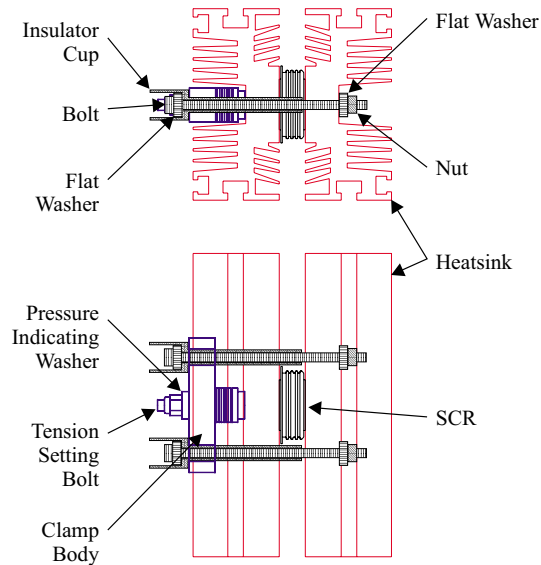

SCR Removal

To remove an SCR loosen the two bolts at each end of the clamp body. The SCR has a dowel pin centering it in the heat sink so the two bolts have to be loosened enough to allow it to clear this pin. **DO NOT** loosen the tension setting bolt(s) or the clamp will be destroyed. The tension setting bolt(s) is adjusted to give the proper clamp tension at the manufacturing factory.

SCR Installation

To install an SCR place it between the heat sinks ensuring that the dowel pin engages the hole in the SCR. Assemble the insulator cups, washers and bolts as shown in the clamp picture. Finger tighten the bolts until they are snug, ensuring that the bolts are evenly tightened and the clamp body is parallel to the heat sink. Tighten each bolt in 1/8 turn increments until the pressure indicator(s) can be turned on the bolt. This ensures the proper clamping pressure on the SCR. For the clamps with two washer stacks, if one pressure indicator is loose and the other is still tight, it may be necessary to tighten one side only or slightly loosen the side that is already tight to get both indicators loose.

6.1 TROUBLESHOOTING

7.

DRAWINGS

7.1 DRAWINGS

RediStart Micro II Computer Card Diagram

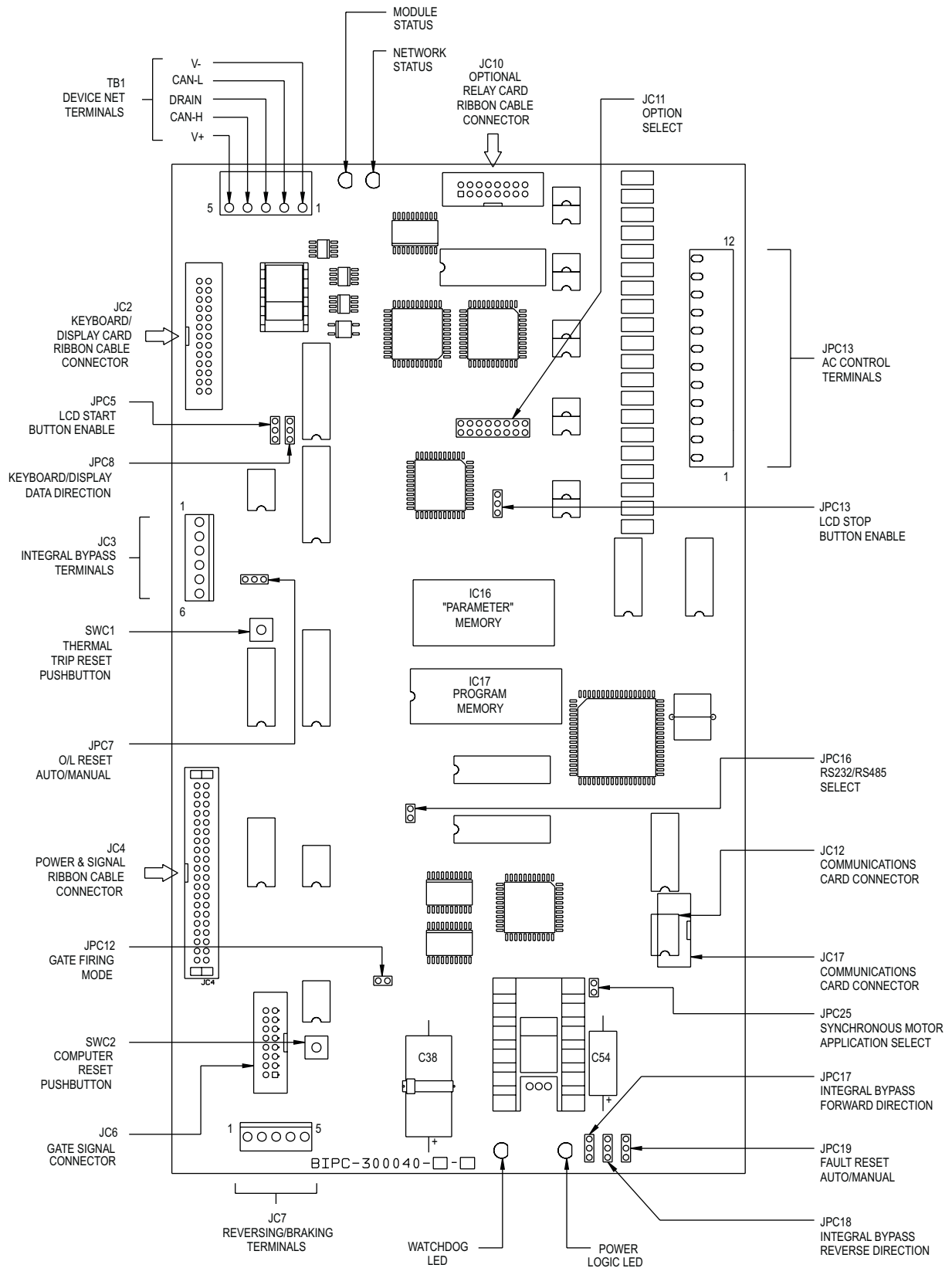

RediStart Micro II Power Card Layout

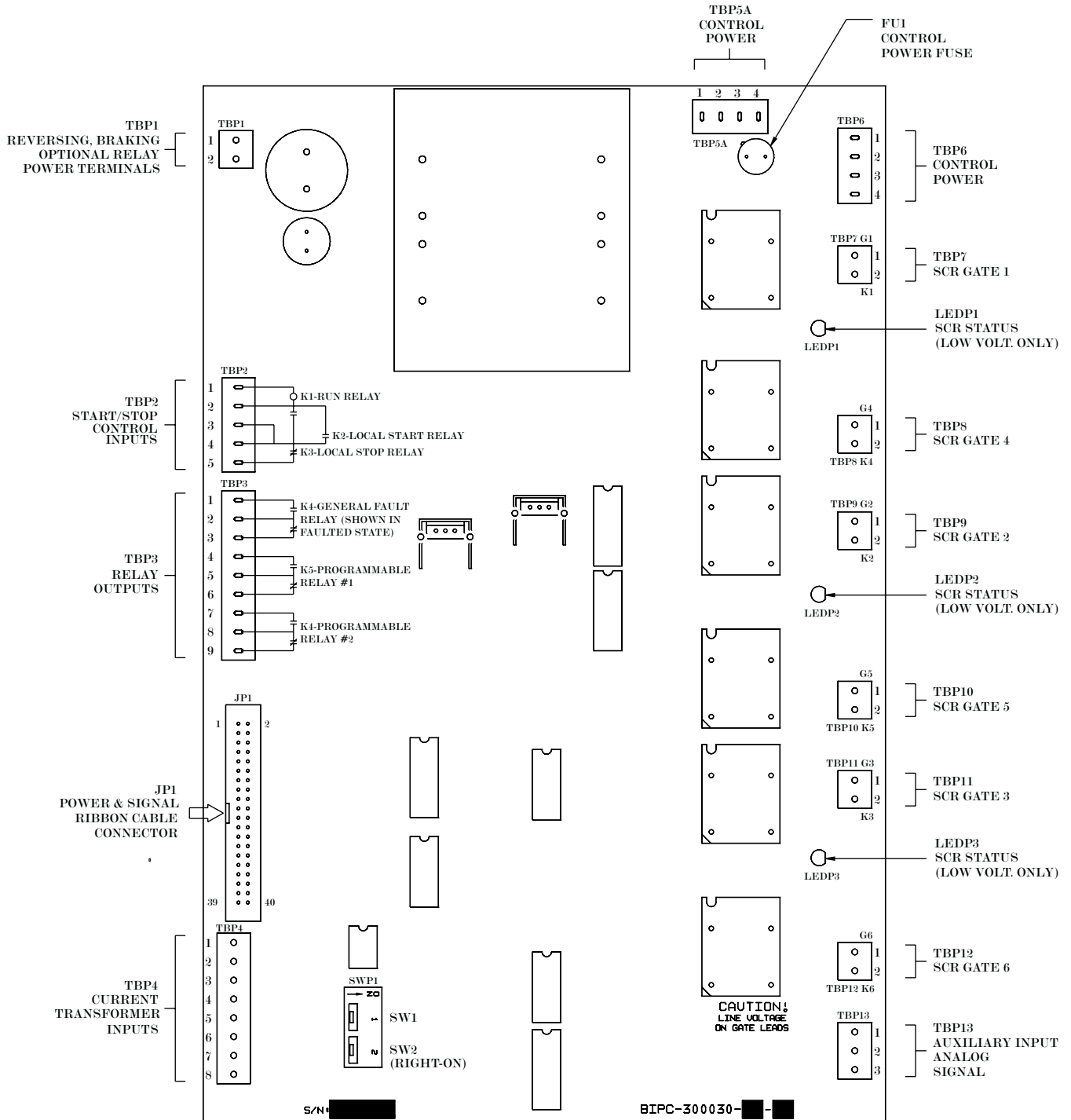

7.1 DRAWINGS

Old RediStart Micro Power Card Layout

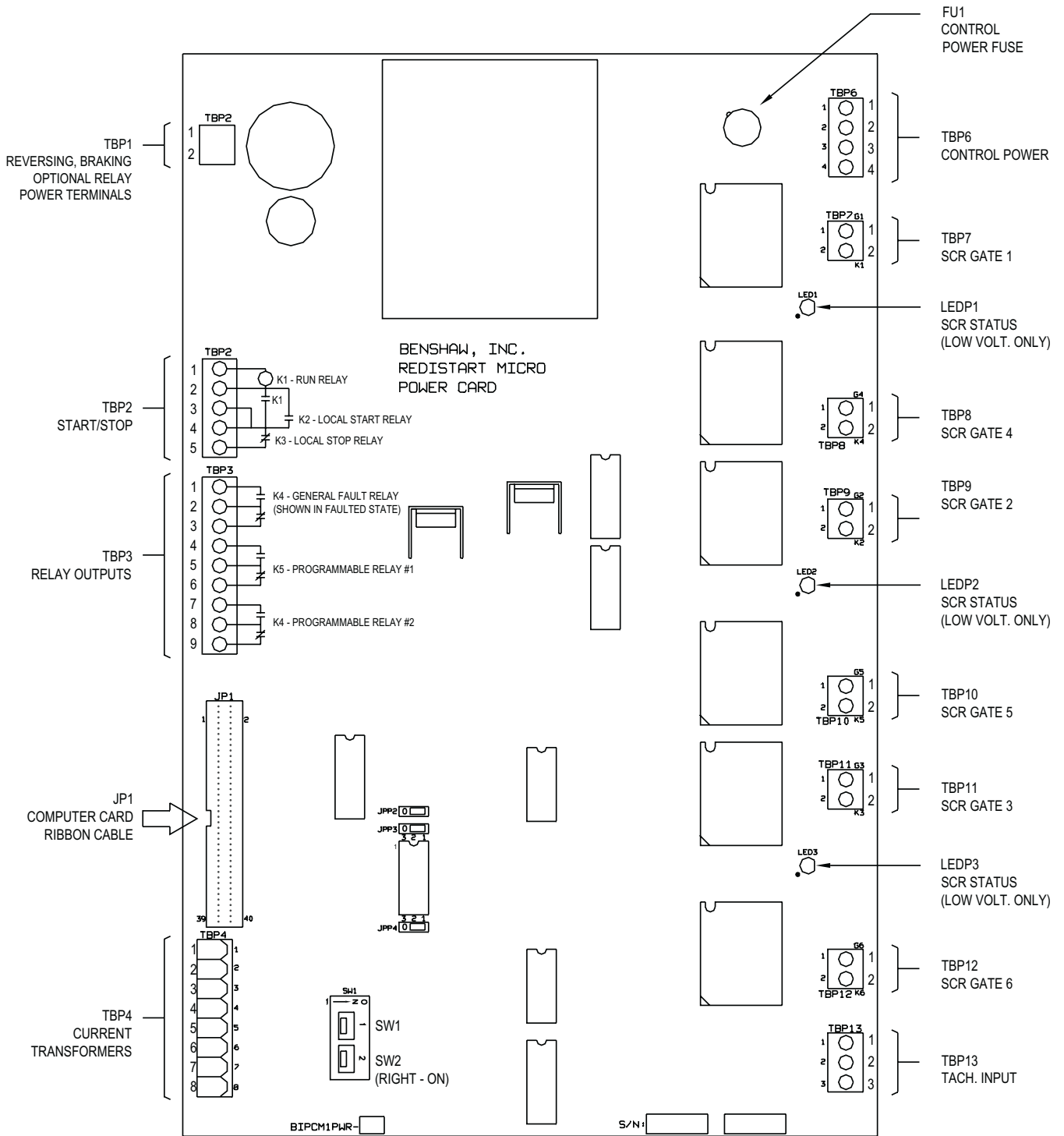

RediStart Micro II Four (4) Relay Card Layout

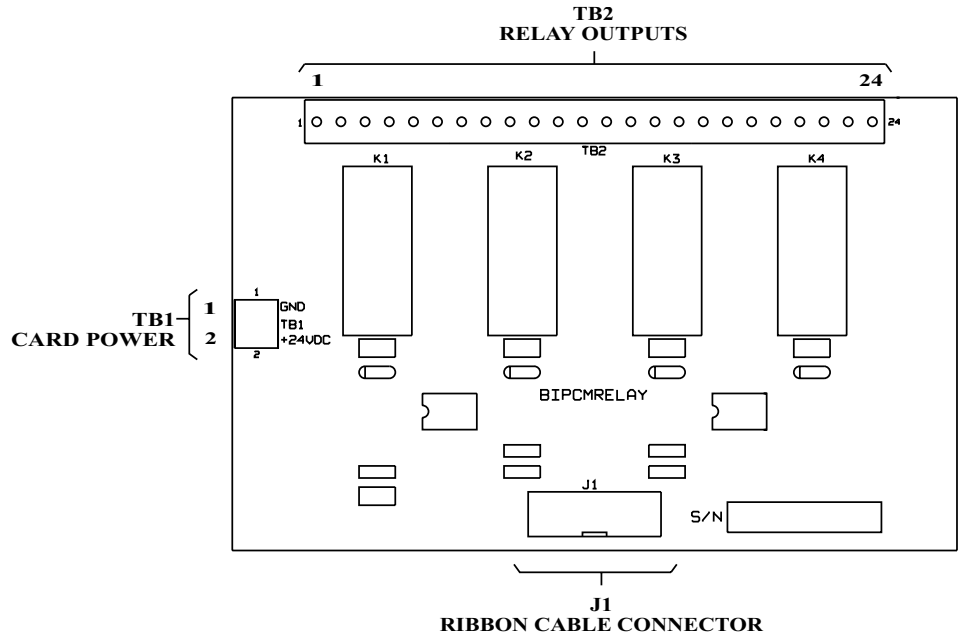

RediStart Micro II Seven (7) Relay Card Layout

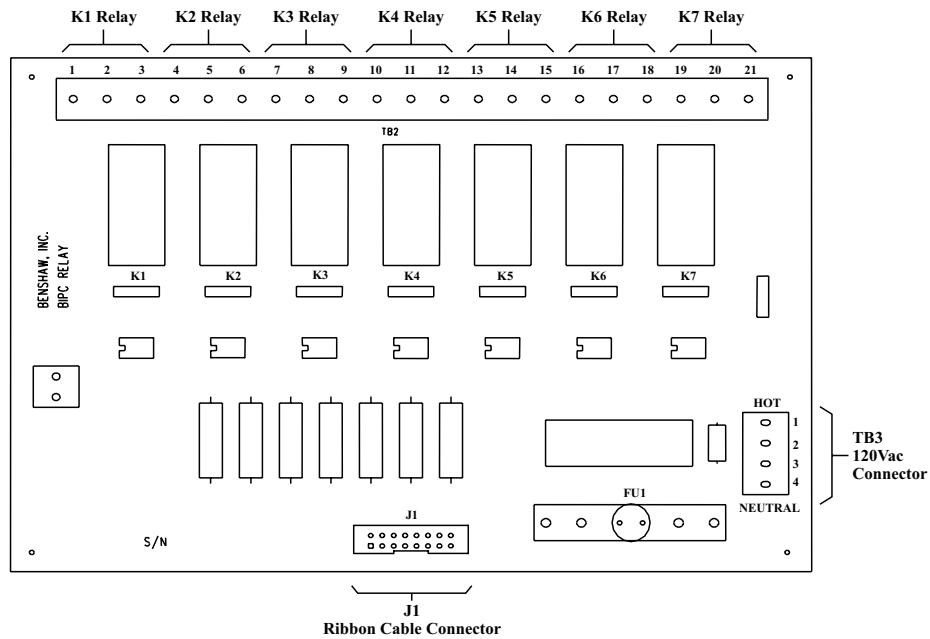

7.1 DRAWINGS

RediStart Micro II RS-232 Communications Card Layout

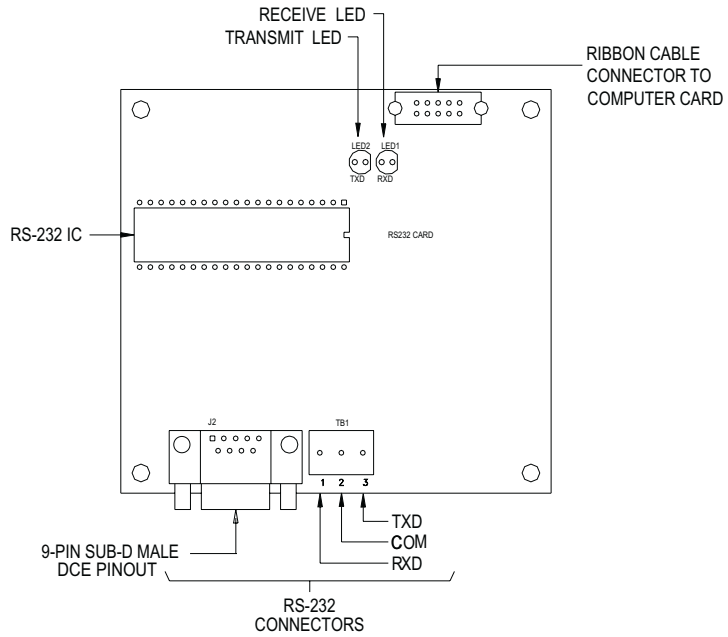

RediStart Micro II RS-485 Communications Card Layout

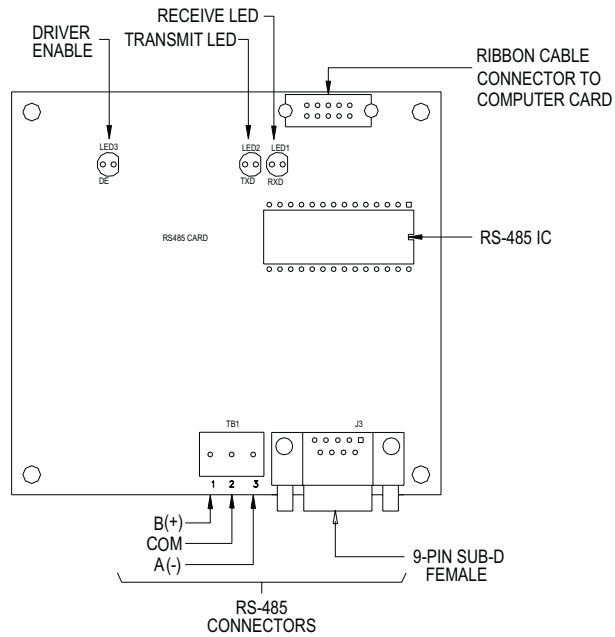

RediStart Micro II RS-232/485 Communications Card Layout

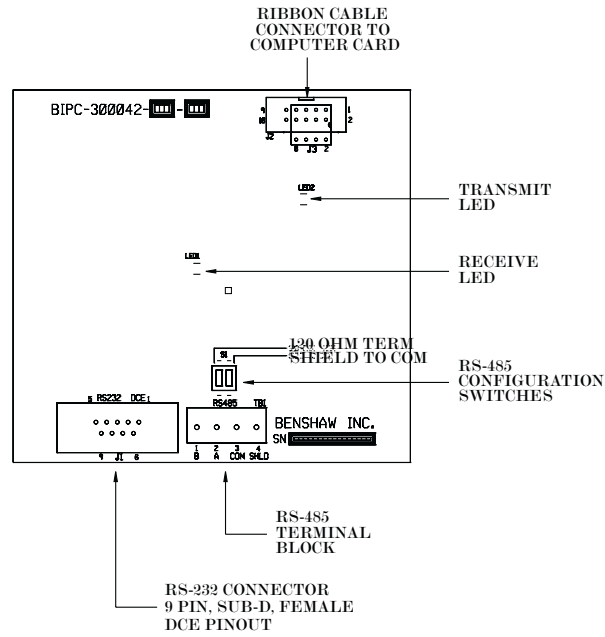

RediStart Micro II Reversing/Braking Card Layout

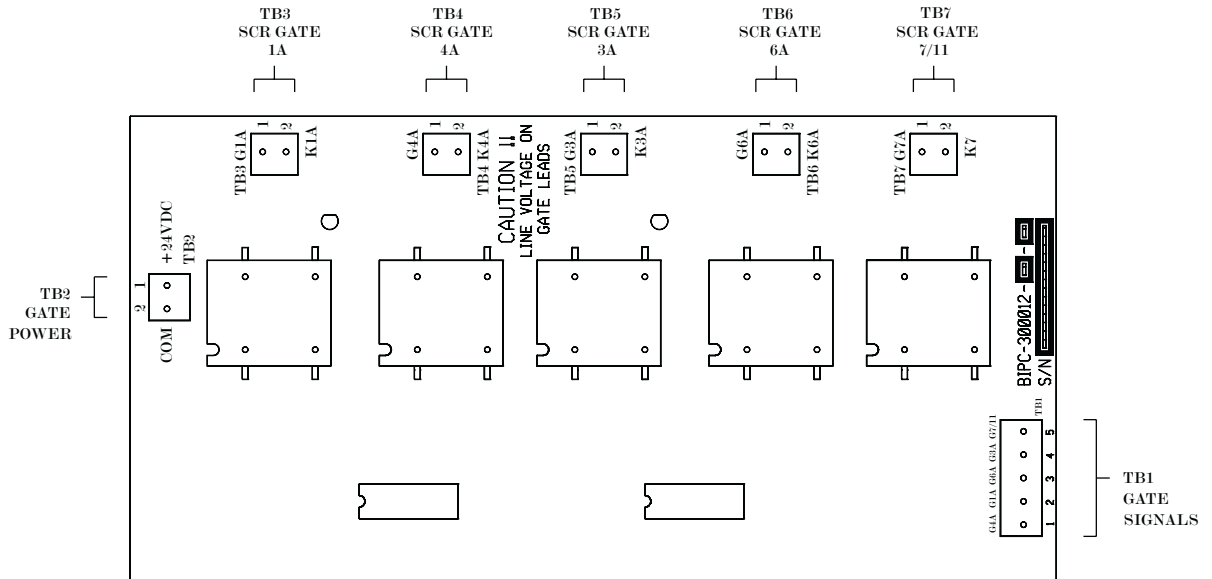

7.1 DRAWINGS

Modbus Master Card (for Remote RTD Module)

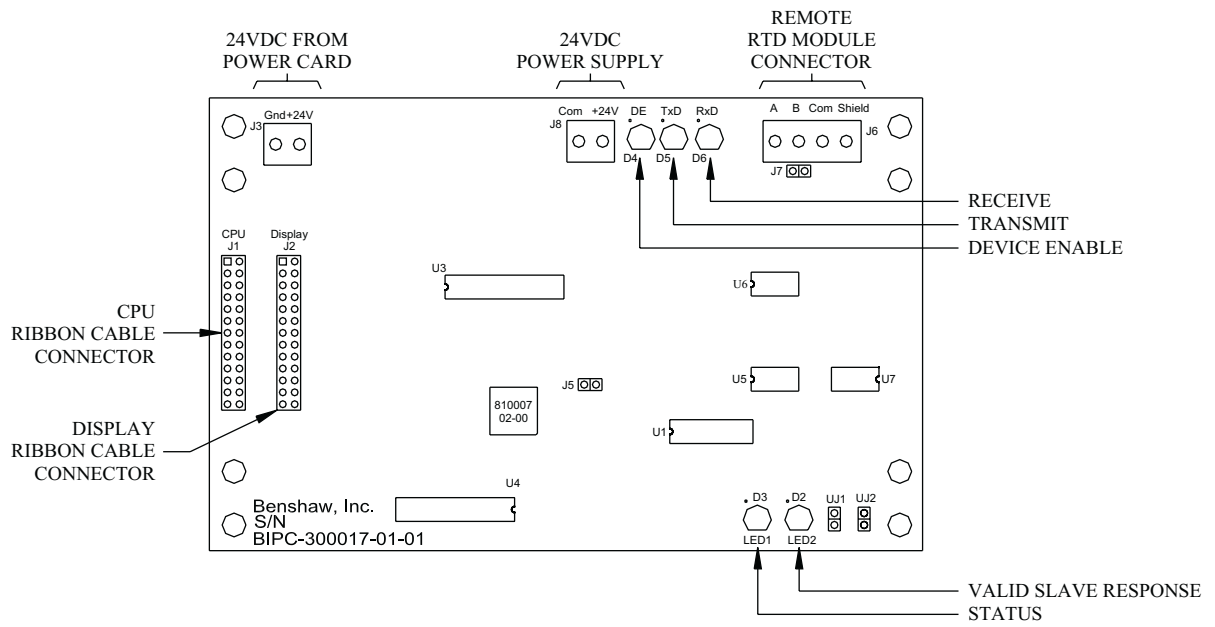

RediStart Micro II Display Cut-out

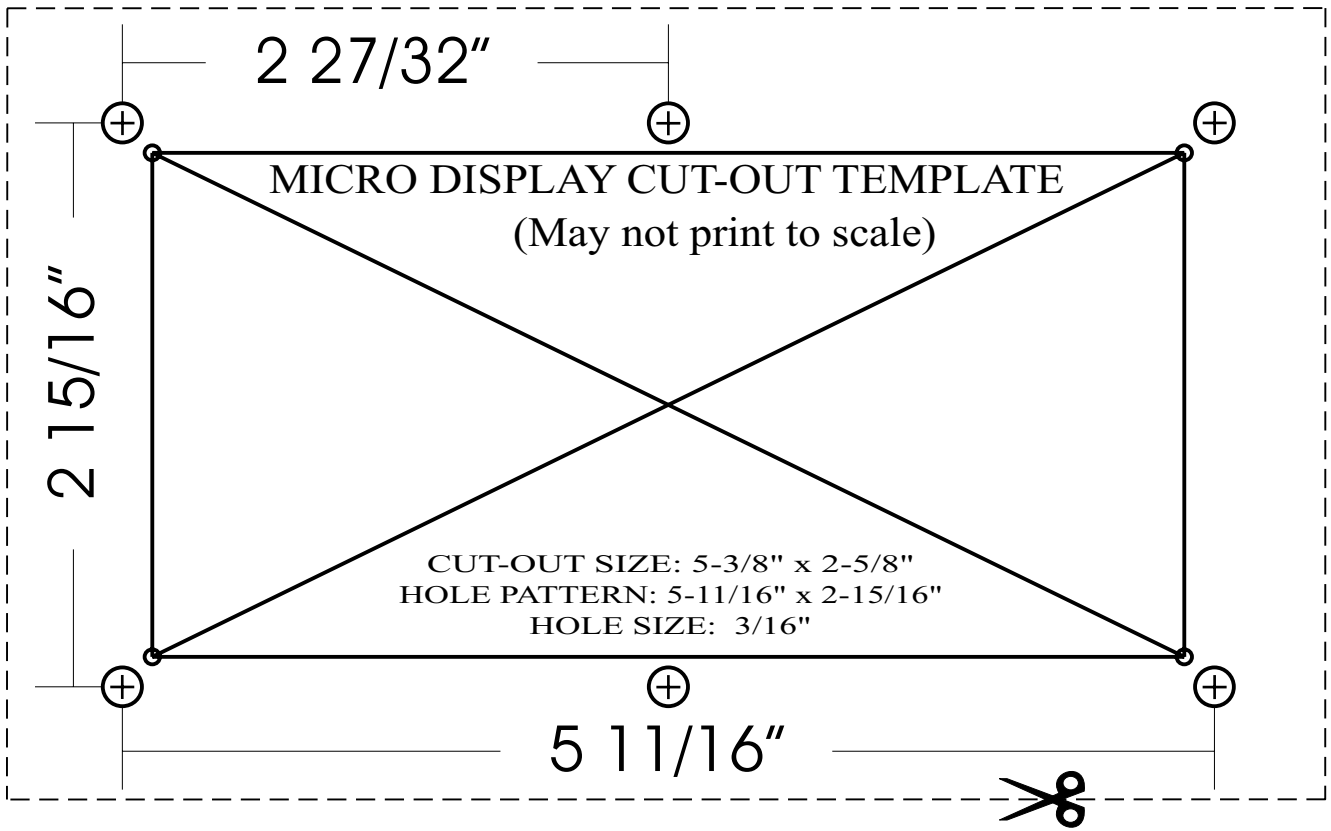

7.1 DRAWINGS

8.

PARAMETER LIST

8.1 Parameter List

RediStart Micro II Parameter List

General

The following pages list the menu parameters for the RediStart Micro II. The list gives the page number where information on the parameter can be found. The list can also be used to record the values that are programmed into the RediStart Micro II for the installation.

Recording Parameters

Each line lists the parameter, page reference, blank, and default setting. The blank spot is for entering the programmed value so that a record of the entered parameters is kept. If the parameter can not be programmed then its value is listed.

NOTE: Not all starters have all of the listed parameters.

Quick Start

	Parameter	Page	Range	Step	Unit	Default	User Setting
Quick Start	Motor FLA	49	1-1200	1	Amps	1	_____
	Serv. Fact	49	1.00-1.99	0.01	%	1.15	_____
	Start Mode	49	Curr, TT, Tach	-	-	Curr	_____
	Stop Mode	49	Coas,VDCL,TT, Brak	-	-	Coas	_____
	Init. Curr.	50	50-400	1	%	100	_____
	Max. Curr.	50	100-600	1	%	600	_____
	Ramp Time	50	0-120	1	sec.	15	_____
	Overload	51	see text	1	-	10	_____
	Phase Orde	51	INS,ABC,CBA	-	-	INS	_____

Motor Nameplate

	Parameter	Page	Range	Step	Unit	Default	User Setting
Motor Nameplate	Motor FLA	52	1-1200	1	Amps	1	_____
	Serv. Fact	52	1.00-1.99	0.01	%	1.15	_____
	Motor RPMs	52	1-3600	1	RPM	1760	_____
	Energy Sav	52	On,Off	-	-	Off	_____
	Source Vol	53	100-1000	1	Volts	Auto	_____

Starter Setup

	Parameter	Page	Range	Step	Unit	Default	User Setting
Starter Mode	Start Mode	54	Curr, TT, Tach	-	-	Curr	_____
	Stop Mode	54	Coas,VDCL,TT, Brak	-	-	Coas	_____
Forward1 Profile	Int. Curr.	55	50-400	1	%	100	_____
	Max. Curr.	55	100-600	1	%	600	_____
	Ramp Time	55	0-120	1	sec.	15	_____
	Kick Curr.	54	100-600	1	%	300	_____
	Kick Time	54	Off,0.1-10.0	0.1	sec.	Off	_____

8.1 Parameter List

	Parameter	Page	Range	Step	Unit	Default	User Setting
Forward2 Profile	Int. Curr.	57	50-400	1	%	100	_____
	Max. Curr.	57	100-600	1	%	600	_____
	Ramp Time	57	0-120	1	sec.	15	_____
	Kick Curr.	58	100-600	1	%	300	_____
	Kick Time	58	Off,0.1-10.0	0.1	sec.	Off	_____

	Parameter	Page	Range	Step	Unit	Default	User Setting
Jog Cntrl Setup	Jog Curr.	59	25-250	1	%	50	_____
	Max. Time	59	1-9000	1	sec.	200	_____
	Kick Curr	60	50-400	1	%	300	_____
	Kick Time	60	0.1-10.0	0.1	sec.	Off	_____
	FWD Speed	60	7,14	-	%	14	_____

	Parameter	Page	Range	Step	Unit	Default	User Setting
Tachometer Setup	FS Volts	61	1.00-7.00	1	-	5.00	_____
	Stab Cnst	61	10-150	1	sec.	100	_____
	Ramp#1 Tim	61	0-120	1	sec.	15	_____
	Ramp#2 Tim	61	0-120	1	sec.	15	_____
	TLoss Dela	62	0.1-90.0	0.1	sec.	1.5	_____
	TLoss Mode	62	TT,Curr,Shut	-	-	Shut	_____

	Parameter	Page	Range	Step	Unit	Default	User Setting
Brake Ctl Setup	Current #1	63	10-100	1	%	25	_____
	Time #1	63	0-30 (HD 0-90)	1	sec.	0	_____
	Current #2	63	10-100	1	%	25	_____
	Time #2	64	0-30 (HD 0-90)	1	sec.	0	_____

	Parameter	Page	Range	Step	Unit	Default	User Setting
Decel Setup	V Level #1	65	10-100	1	%	40	_____
	V Level #2	65	1-99	1	%	20	_____
	VDCL Time	65	0-60	1	sec.	0	_____
	TT DCL Tim	65	0-100	1	sec	0	_____
	TT DCL Tor	65	1-100	1	%	10	_____

	Parameter	Page	Range	Step	Unit	Default	User Setting
PORT Ctl Setup	Fault Dly	67	OFF,0.1-90.0	0.1	sec.	OFF	_____
	Bypass Dly	67	0.0-3.0	0.1	sec.	0.0	_____
	Sense Time	67	0.01-0.50	0.01	sec.	0.05	_____

	Parameter	Page	Range	Step	Unit	Default	User Setting
TruTorque Ramp	Int Torque	68	1-100	1	%	20	_____
	Max Torque	68	10-325	1	%	105	_____
	Ramp Time	68	0-120	1	sec.	15	_____
	TT OVR Cu	69	Off,100-800	1	%	Off	_____
	Ovr Cur Dl	69	0.1-90.0	1	sec.	0.1	_____

8.1 Parameter List

	<u>Parameter</u>	<u>Page</u>	<u>Range</u>	<u>Step</u>	<u>Unit</u>	<u>Default</u>	<u>User Setting</u>
Heat/Anti-wind	Heat Curr.	70	5-25	1	%	10	_____

Motor Protection

	<u>Parameter</u>	<u>Page</u>	<u>Range</u>	<u>Step</u>	<u>Unit</u>	<u>Default</u>	<u>User Setting</u>
Overload Class	Overload	71	see text	1	-	10	_____

	<u>Parameter</u>	<u>Page</u>	<u>Range</u>	<u>Step</u>	<u>Unit</u>	<u>Default</u>	<u>User Setting</u>
Line Current	% Imbalanc	72	10-40	1	%	15	_____
	Imbal Dela	72	0.1-90.0	0.1	sec.	0.5	_____
	@ Stop Dly	72	0.1-10.0	0.1	sec.	1.5	_____
	% No C@Run	73	2-40	1	%	5	_____
	No C@R Dly	73	0.1-90.0	0.1	sec.	1.0	_____

	<u>Parameter</u>	<u>Page</u>	<u>Range</u>	<u>Step</u>	<u>Unit</u>	<u>Default</u>	<u>User Setting</u>
Line Voltage	H/L Volts	74	10-30	1	%	20	_____
	Delay Time	74	0.1-90.0	0.1	sec.	0.5	_____
	PH Dect Dl	74	0.3-5.0	0.1	sec.	0.8	_____

	<u>Parameter</u>	<u>Page</u>	<u>Range</u>	<u>Step</u>	<u>Unit</u>	<u>Default</u>	<u>User Setting</u>
Line Frequency	High Freq.	75	72-24	1	hz	72	_____
	Low Freq.	75	23-71	1	hz	23	_____
	Freq Delay	75	0.1-90.0	0.1	sec.	0.1	_____

	<u>Parameter</u>	<u>Page</u>	<u>Range</u>	<u>Step</u>	<u>Unit</u>	<u>Default</u>	<u>User Setting</u>
Ground Fault	GND Fault	76	1-100	1	Amps	Off	_____
	GND Delay	76	0.1-90.0	0.1	sec.	1.0	_____

	<u>Parameter</u>	<u>Page</u>	<u>Range</u>	<u>Step</u>	<u>Unit</u>	<u>Default</u>	<u>User Setting</u>
Shorted SCR	@ Ramp DLY	77	0.1-90.0	0.1	sec.	0.2	_____
	@ Stop DLY	77	0.1-90.0	0.1	sec.	1.0	_____

	<u>Parameter</u>	<u>Page</u>	<u>Range</u>	<u>Step</u>	<u>Unit</u>	<u>Default</u>	<u>User Setting</u>
Over Curr. Trip	Current	78	50-800,Off	1	%	Off	_____
	Detect Dly	78	0.1-90.0	0.1	sec.	0.1	_____
	Release Dl	78	1.0-90.0	0.1	sec.	10.0	_____

	<u>Parameter</u>	<u>Page</u>	<u>Range</u>	<u>Step</u>	<u>Unit</u>	<u>Default</u>	<u>User Setting</u>
Under Curr. Trip	Current	79	10-100	1	%	Off	_____
	Detect Dly	79	0.1-90.0	0.1	sec.	0.1	_____
	Release Dl	79	1.0-90.0	0.1	sec.	10.0	_____

8.1 Parameter List

	Parameter	Page	Range	Step	Unit	Default	User Setting
Start Lockouts	Starts/Hou	80	1-20	1	#	Off	_____
	Time Start	80	1-600	1	min.	Off	_____
	BKS Timer	80	1-200	1	min.	Off	_____
	Parameter	Page	Range	Step	Unit	Default	User Setting
Starting Timers	UTS Timer	81	Off,1-300	1	sec.	30	_____
	Zero Speed	81	Off,1-30	1	sec.	Off	_____
	Parameter	Page	Range	Step	Unit	Default	User Setting
Permissive Input	Therm. In	82	0.1-90.0	0.1	sec.	0.5	_____
	Parameter	Page	Range	Step	Unit	Default	User Setting
Misc.	Phase Order	83	INS,ABS,CBA	-	-	INS	_____
	# Auto RST	83	1-5	1	#	4	_____
	No Main PW	83	1-5	1	sec.	1	_____
	Parameter	Page	Range	Step	Unit	Default	User Setting
Fault Classes	Fault# 1	84	see text	-	-	NonC	_____
	Fault# 2	84	see text	-	-	NonC	_____
	Fault# 3	84	see text	-	-	NonC	_____
	Fault# 4	84	see text	-	-	NonC	_____
	Fault# 5	84	see text	-	-	NonC	_____
	Fault# 6	84	see text	-	-	NonC	_____
	Fault# 7	84	see text	-	-	NonC	_____
	Fault# 8	84	see text	-	-	NonC	_____
	Fault# 9	84	see text	-	-	NonC	_____
	Fault#15	84	see text	-	-	Crit	_____
	Fault#16	84	see text	-	-	Crit	_____
	Fault#17	84	see text	-	-	NonC	_____
	Fault#18	84	see text	-	-	NonC	_____
	Fault#19	84	see text	-	-	NonC	_____
	Fault#20	84	see text	-	-	NonC	_____
	Fault#21	84	see text	-	-	NonC	_____
	Fault#22	84	see text	-	-	NonC	_____
	Fault#23	84	see text	-	-	NonC	_____
	Fault#24	84	see text	-	-	NonC	_____
	Fault#25	84	see text	-	-	NonC	_____
	Fault#26	84	see text	-	-	NonC	_____
	Fault#27	84	see text	-	-	NonC	_____
	Fault#28	84	see text	-	-	NonC	_____
	Fault#29	84	see text	-	-	Crit	_____
	Fault#30	84	see text	-	-	Crit	_____
	Fault#31	84	see text	-	-	NonC	_____
	Fault#46	84	see text	-	-	NonC	_____
	Fault#49	84	see text	-	-	Crit	_____
	Fault#50	84	see text	-	-	Crit	_____

8.1 Parameter List

Fault#51	84	see text	-	-	NonC	_____
Fault#52	84	see text	-	-	Crit	_____
Fault#53	84	see text	-	-	NonC	_____
Fault#64	84	see text	-	-	NonC	_____
Fault#65	84	see text	-	-	NonC	_____
Fault#66	84	see text	-	-	NonC	_____
Fault#67	84	see text	-	-	Crit	_____
Fault#68	84	see text	-	-	NonC	_____
Fault#69	84	see text	-	-	Dis	_____
Fault#70	84	see text	-	-	NonC	_____
Fault#71	84	see text	-	-	NonC	_____
Fault#72	84	see text	-	-	Crit	_____
Fault#73	84	see text	-	-	NonC	_____
Fault#74	84	see text	-	-	NonC	_____
Fault#75	84	see text	-	-	NonC	_____
Fault#76	84	see text	-	-	NonC	_____
Fault#77	84	see text	-	-	NonC	_____
Fault#78	84	see text	-	-	NonC	_____
Fault#79	84	see text	-	-	NonC	_____
Fault#80	84	see text	-	-	NonC	_____
Fault#81	84	see text	-	-	NonC	_____
Fault#82	84	see text	-	-	NonC	_____
Fault#83	84	see text	-	-	NonC	_____
Fault#84	84	see text	-	-	NonC	_____
Fault#87	84	see text	-	-	Crit	_____
Fault#88	84	see text	-	-	NonC	_____
Fault#89	84	see text	-	-	NonC	_____
Fault#90	84	see text	-	-	Crit	_____
Fault#91	84	see text	-	-	Crit	_____
Fault#92	84	see text	-	-	Crit	_____
Fault#93	84	see text	-	-	Crit	_____
Fault#94	84	see text	-	-	Crit	_____
Fault#95	84	see text	-	-	Crit	_____
Fault#96	84	see text	-	-	Crit	_____
Fault#97	84	see text	-	-	Crit	_____
Fault#98	84	see text	-	-	NonC	_____
Fault#99	84	see text	-	-	Crit	_____

Meters & Relays

	Parameter	Page	Range	Step	Unit	Default	User Setting
Meter Setup	Meter #1	85	see text	-	-	Asc	_____
	Meter #2	85	see text	-	-	Vsc	_____
	AutoRange	86	50.0-99.9	0.1	#	99.9	_____
	Meter Rsts	86	see text	-	-	None	_____
	Scroll Tim	86	Off,1-120	1	sec.	Off	_____

8.1 Parameter List

	<u>Parameter</u>	<u>Page</u>	<u>Range</u>	<u>Step</u>	<u>Unit</u>	<u>Default</u>	<u>User Setting</u>
Standard Relays	Relay#1,K5	87	see text	-	-	RUN	_____
	Relay#2,K6	87	see text	-	-	UTS	_____

	<u>Parameter</u>	<u>Page</u>	<u>Range</u>	<u>Step</u>	<u>Unit</u>	<u>Default</u>	<u>User Setting</u>
Extended Relays	Opt. #1,K1	88	see text	-	-	varies	_____
	Opt. #2,K2	88	see text	-	-	varies	_____
	Opt. #3,K3	88	see text	-	-	varies	_____
	Opt. #4,K4	88	see text	-	-	varies	_____
	Opt. #5,K5	88	see text	-	-	varies	_____
	Opt. #6,K6	88	see text	-	-	varies	_____
	Opt. #7,K7	88	see text	-	-	varies	_____

Event Recorder

	<u>Parameter</u>	<u>Page</u>	<u>Range</u>	<u>Step</u>	<u>Unit</u>	<u>Default</u>	<u>User Setting</u>
Event Recorder	Event recorder	89	last 99 events				

Control Config

	<u>Parameter</u>	<u>Page</u>	<u>Range</u>	<u>Step</u>	<u>Unit</u>	<u>Default</u>	<u>User Setting</u>
System Clock	Minutes	91	0-60	1	min.	0	_____
	Hours	91	0-23	1	hour	0	_____
	Day	91	1-31	1	day	1	_____
	Month	91	1-12	1	month	0	_____
	Year	91	0-99	1	year	0	_____

	<u>Parameter</u>	<u>Page</u>	<u>Range</u>	<u>Step</u>	<u>Unit</u>	<u>Default</u>	<u>User Setting</u>
System Password	Password	92	001-999	1	-	Off	_____

	<u>Parameter</u>	<u>Page</u>	<u>Range</u>	<u>Step</u>	<u>Unit</u>	<u>Default</u>	<u>User Setting</u>
Comm Settings	COMM. Mode	93	see text	-	-	Off	_____
	COM Addres	93	0-255	1	#	127	_____
	COM Delay	93	0.02-2.00	0.01	sec.	0.35	_____
	MB:Baud	94	see text	-	bps	2400	_____
	MB:Comm T/O	94	1-900	1	sec.	Off	_____
	DN:MAC ID	94	0-63	1	#	63	_____
	DN:Baud	94	see text	-	bps	125	_____
	DN:InAssy	95	see text	-	#	61	_____
	DN:OutAssy	95	see text	-	#	100	_____
DN:T/O Act	95	none,stop	-	#	none	_____	

	<u>Parameter</u>	<u>Page</u>	<u>Range</u>	<u>Step</u>	<u>Unit</u>	<u>Default</u>	<u>User Setting</u>
Options List	Options listed	96					

	<u>Parameter</u>	<u>Page</u>	<u>Range</u>	<u>Step</u>	<u>Unit</u>	<u>Default</u>	<u>User Setting</u>
Software Part#	Software Part#	97	see text				

8.1 Parameter List

Factory Setup

	<u>Parameter</u>	<u>Page</u>	<u>Range</u>	<u>Step</u>	<u>Unit</u>	<u>Default</u>	<u>User Setting</u>
Hardware Setup	C.T. Ratio	98	see text	-	#	288	_____
	Relay Card	98	see text	-	-	None	_____
	<u>Parameter</u>	<u>Page</u>	<u>Range</u>	<u>Step</u>	<u>Unit</u>	<u>Default</u>	<u>User Setting</u>
Factory Control	FACT Pass.	99	see text				

RTD Setup

	<u>Parameter</u>	<u>Page</u>	<u>Range</u>	<u>Step</u>	<u>Unit</u>	<u>Default</u>	<u>User Setting</u>
RTD Module Setup	Mod#1 Addr	101	16-23	1	#	16	_____
	Mod#2 Addr	101	16-23	1	#	17	_____
	#RTDs Mod1	101	None,1-8	1	#	None	_____
	#RTDs Mod2	101	none,1-8	1	#	None	_____
	Temp Scale	101	C,F	-	-	C	_____
	<u>Parameter</u>	<u>Page</u>	<u>Range</u>	<u>Step</u>	<u>Unit</u>	<u>Default</u>	<u>User Setting</u>
RTD Setpnts 1-8	RTD#1 Grp	102	see text	-	-	None	_____
	RTD#1 Warn	102	see text	1	temp	Off	_____
	RTD#1 Alm	102	see text	1	temp	Off	_____
	RTD#2 Grp	102	see text	-	-	None	_____
	RTD#2 Warn	102	see text	1	temp	Off	_____
	RTD#2 Alm	102	see text	1	temp	Off	_____
	RTD#3 Grp	102	see text	-	-	None	_____
	RTD#3 Warn	102	see text	1	temp	Off	_____
	RTD#3 Alm	102	see text	1	temp	Off	_____
	RTD#4 Grp	102	see text	-	-	None	_____
	RTD#4 Warn	102	see text	1	temp	Off	_____
	RTD#4 Alm	102	see text	1	temp	Off	_____
	RTD#5 Grp	102	see text	-	-	None	_____
	RTD#5 Warn	102	see text	1	temp	Off	_____
	RTD#5 Alm	102	see text	1	temp	Off	_____
	RTD#6 Grp	102	see text	-	-	None	_____
	RTD#6 Warn	102	see text	1	temp	Off	_____
	RTD#6 Alm	102	see text	1	temp	Off	_____
	RTD#7 Grp	102	see text	-	-	None	_____
	RTD#7 Warn	102	see text	1	temp	Off	_____
	RTD#7 Alm	102	see text	1	temp	Off	_____
	RTD#8 Grp	102	see text	-	-	None	_____
	RTD#8 Warn	102	see text	1	temp	Off	_____
	RTD#8 Alm	102	see text	1	temp	Off	_____

8.1 Parameter List

	Parameter	Page	Range	Step	Unit	Default	User Setting
RTD Setpnts 9-16	RTD#9 Grp	103	see text	-	-	None	_____
	RTD#9 Warn	103	see text	1	temp	Off	_____
	RTD#9 Alm	103	see text	1	temp	Off	_____
	RTD#10Grp	103	see text	-	-	None	_____
	RTD#10Warn	103	see text	1	temp	Off	_____
	RTD#10Alm	103	see text	1	temp	Off	_____
	RTD#11Grp	103	see text	-	-	None	_____
	RTD#11Warn	103	see text	1	temp	Off	_____
	RTD#11Alm	103	see text	1	temp	Off	_____
	RTD#12Grp	103	see text	-	-	None	_____
	RTD#12Warn	103	see text	1	temp	Off	_____
	RTD#12Alm	103	see text	1	temp	Off	_____
	RTD#13Grp	103	see text	-	-	None	_____
	RTD#13Warn	103	see text	1	temp	Off	_____
	RTD#13Alm	103	see text	1	temp	Off	_____
	RTD#14Grp	103	see text	-	-	None	_____
RTD#14Warn	103	see text	1	temp	Off	_____	
RTD#14Alm	103	see text	1	temp	Off	_____	
RTD#15Grp	103	see text	-	-	None	_____	
RTD#15Warn	103	see text	1	temp	Off	_____	
RTD#15Alm	103	see text	1	temp	Off	_____	
RTD#16Grp	103	see text	-	-	None	_____	
RTD#16Warn	103	see text	1	temp	Off	_____	
RTD#16Alm	103	see text	1	temp	Off	_____	

8.1 Parameter List

BENSHAW PRODUCTS

Low Voltage Solid State Reduced Voltage Starters

- ◆ RSD/RSM6 - SSRV Non or Separate Bypass
- ◆ RDB/RMB6 - SSRV Integral Bypass
- ◆ RSM7 - SSRV + DC Injection Braking
- ◆ RSM10 - SSRV + Reversing
- ◆ RSM11 - SSRV + DC Injection Braking + Reversing
- ◆ RSM10/12TS - SSRV Two Speed
- ◆ WRSM6 - SSRV Wound Rotor
- ◆ SMRSM6 - SSRV Synchronous
- ◆ DCB3 - Solid State DC Injection Braking

Medium Voltage Solid State Reduced Voltage Starters

- ◆ 5kV - Induction or Synchronous to 10,000HP
- ◆ 7.2kV - Induction or Synchronous to 10,000HP
- ◆ 15kV - Induction or Synchronous to 60,000HP

Low Voltage - AC Drives

- ◆ Standard Drives to 1000HP
- ◆ Custom Industrial Packaged Drives
- ◆ HVAC Packaged Drives
- ◆ 18 Pulse/IEEE 519 Compliant Drives

RSC Series Contactors

- ◆ SPO/SPE/SPD Motor Protection Relays
- ◆ Enclosed Full Voltage, Wye Delta, Two Speed
Part Winding and Reversing Starters

Custom OEM Controls

Sales and Service

United States

Pittsburgh, Pennsylvania
Dayton, Ohio
Syracuse, New York
Boston, Massachusetts
Wilmington, Delaware
Charlotte, North Carolina
Jacksonville, Florida
Birmingham, Alabama
Los Angeles, California
Detroit, Michigan
Eagan, Minnesota
LaCrosse, Wisconsin
Chicago, Illinois
St. Lois, Missouri
Phoenix, Arizona
Seattle, Washington
Denver, Colorado
Houston, Texas

Canada

Listowel, Ontario
Toronto, Ontario
Montreal, Quebec
Calgary, Alberta

South America

Sao Paulo, Brazil
Santiago, Chile
Lima, Peru
Bogota, Columbia

Shanghai

Australia

Singapore

Visit Benshaw on the
world wide web at
www.benshaw.com, or
contact:

BENSHAW Inc.

1659 East Sutter Road
Glenshaw, PA 15116
Phone: (412) 487-8235
Fax: (412) 487-4201

BENSHAW West

14715 North 78th Way
Suite 600
Scottsdale, AZ 85260
Phone: (480) 905-0601
Fax: (480) 905-0757

BENSHAW Canada

550 Bright Street East,
Listowel, Ontario
N4W 3W3
Phone: (519) 291-5112
Fax: (519) 291-2595